

# RUH | OXFORD™

COMMERCIAL AND RESIDENTIAL UNIT HEATER



**OXFORD™**  
SERIES | SÉRIE



## A VERSATILE WORKHORSE

The RUH unit heater is small on price and big on heat. These heavy-duty units are well suited to situations where large amounts of heat must be provided in wide open spaces such as garages, workshops, commercial warehouses and construction sites. This unit has a powerful output up to 5000 W with a voltage of 240/208. The RUH has adjustable louvers that allow you to direct heat right from the source. With or without a built-in thermostat, it provides instant heat. Quiet, lightweight and easy-to-install with a universal wall or ceiling mounting bracket, this unit heater is everything you expect for less. Guaranteed productivity!

### INSTANT HEAT

### ADJUSTABLE LOUVERS ALLOW YOU TO DIRECT HEAT

### WALL OR CEILING INSTALLATION SUPPORT BRACKET INCLUDED

### ENCLOSED AND PERMANENTLY LUBRICATED MOTOR

### 2 KW TO 5 KW MODELS AVAILABLE

### COLOUR

- charcoal

### FINISH

- epoxy-polyester powdercoat

### MANUFACTURING

- 20-gauge steel cabinet
- totally enclosed and factory lubricated motor
- 350 CFM quiet helicoidal fan
- adjustable louvers
- thermal protection with automatic reset

### ELEMENT

- nichrome element produces instant heat

### CONTROL

- built-in thermostat (included with T series)
- wall thermostat (not included)

### INSTALLATION

- wall or ceiling mounted with universal mounting bracket (included with unit)

### WARRANTY

- three years

### IDEAL FOR:

construction site, garage, workshop, small commercial space

°**STELPRO**

°STELPRO reserves the right to modify descriptions, manufacturing specifications or prices without prior notice. No returns accepted on optional-colour products. For all the latest models and prices, please refer to our website at [www.stelpro.com](http://www.stelpro.com).





## TECHNICAL SPECIFICATIONS

WITHOUT CONTROL		BUILT-IN THERMOSTAT		24 V CONTROL		POWER	VOLTAGE	FLOW	THROW DISTANCE		HEAT RISE		WEIGHT	
CODE	PRICE	CODE	PRICE	CODE	PRICE	WATT S	VOLTS	CFM	M	FT.	°C	°F	KG	LB
RUH2CHAR	359.00	RUH2TCHAR	371.00	RUH2C24CHAR	402.00	2000/1500	240/208	350	3	10	27	48	9	20
RUH3CHAR	365.00	RUH3TCHAR	377.00	RUH3C24CHAR	408.00	3000/2250	240/208	350	3	10	34	60	9	20
RUH4CHAR	372.00	RUH4TCHAR	384.00	RUH4C24CHAR	415.00	4000/3000	240/208	350	3	10	46	82	9	20
RUH5CHAR	377.00	RUH5TCHAR	389.00	RUH5C24CHAR	420.00	5000/3750	240/208	350	3	10	64	114	9	20

## TECHNICAL DRAWINGS

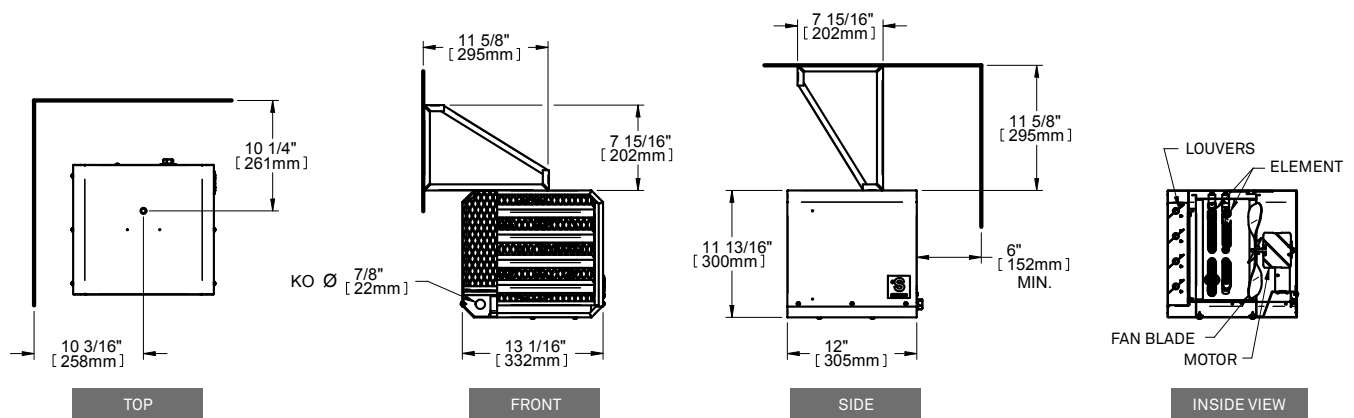

\*STELPRO reserves the right to modify descriptions, manufacturing specifications or prices without prior notice. No returns accepted on optional-colour products. For all the latest models and prices, please refer to our website at [www.stelpro.com](http://www.stelpro.com).