

CD-2001-XXX, CD-920-XXX

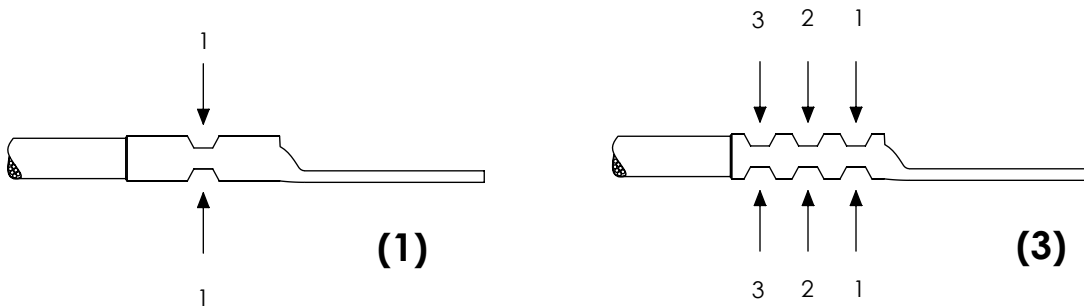

Using installation tooling shown on other side, insert connector in die and crimp between color bands or knurl markings, use these markings as a guide to evenly space crimps on barrel of connector. Begin crimping near the tongue end of the lug and continue crimping toward the wire end. REQUIRED NUMBER OF COMPRESSIONS SHOWN ON TOOL CHART IN ().

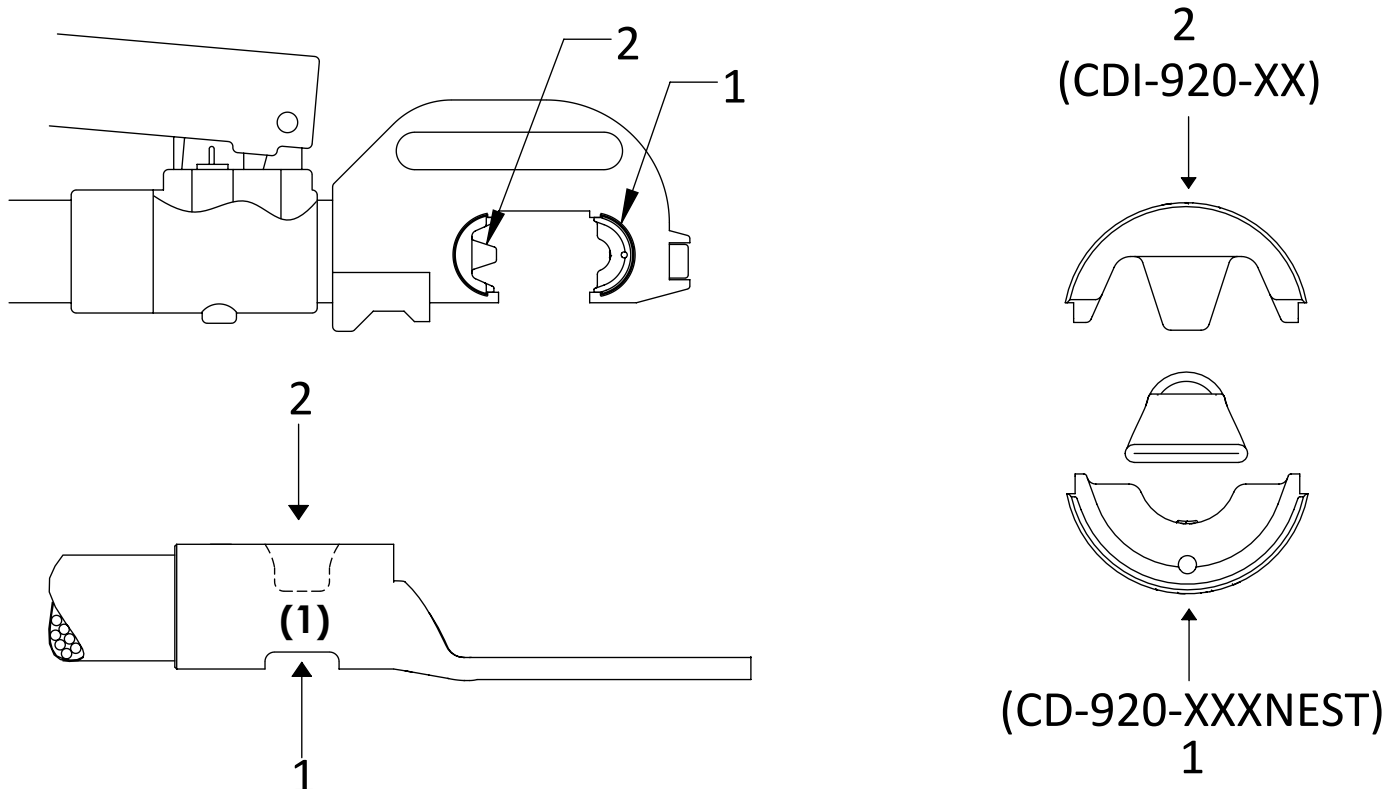

Tool Chart for Compression Connectors Types LCMA, LCMD, LCDN, and SCMS with Metric Class 2, 5, & 6 Copper Cable

Panduit Part No.	Wire Size & Class 2r	Wire Strip Length (mm)	Panduit Tool Part Number (For Class 2 Wire)						A See Tool List Below	B See Tool List Below
			CT-100 (Manual)	CT-200 CT-1570 (Manual)	CT-600 (Air)	CT-1701 (Manual)	Cembre Tool Part Number***			
							HTI31-C HT-131LN-C RHC 131LN B 131-C B 131-C-KV B 131LN-C B 131-UC (14.6 Ton Hyd.)			
			Die Pocket Number (Crimp Qty.)				Die Part Number Color & Die Index Number (Crimp Qty.)			
LCMA2.5	1.5-2.5 Class 2r	-	22-10 (1)	22-14 (1) 16-14 (1)	CT-570 16-14 (1)	P10 (1)	-	-		
LCMA6 LCMD6	4 - 6mm ² Class 2r	-	22-10 (2)	12-10 (2)	CT-570 12-10 (2)	P10 (2)	-	-		
LCMA10 LCMD10 SCMS10	10mm ² Class 2r	- - 16.5	-	-	-	-	CD-2001-8 Red P21 (1)	CD-920-8 Red P21 (1)		
LCMA16 LCMD16 SCMS16	16mm ² Class 2r	- - 19.0	-	-	-	-	CD-2001-8 Red P21 (1)	CD-920-8 Red P21 (1)		
LCMA25 LCMD25	25mm ² Class 2r	- - 19.5	-	-	-	-	CD-2001-4 Gray P29 (1)	CD-920-4 Gray P29 (1)		
SCMS25										
LCMA35 LCMD35 SCMS35	35mm ² Class 2r	- - 19.5	-	-	-	-	CD-2001-4 Gray P29 (1)	CD-920-4 Gray P29 (1)		
LCMA50 LCMD50 SCMS50	50mm ² Class 2r	- - 26.0	-	-	-	-	CD-2001-1 Green P37 (1)	CD-920-1 Green P37 (1)		
LCMA70 LCMD70 SCMS70	70mm ² Class 2r	- - 27.5	-	-	-	-	CD-2001-2/0 Black P45 (2)	CD-920-2/0 Black P45 (2)		
LCMA95 LCMD95 SCMS95	95mm ² Class 2r	- - 28.5	-	-	-	-	CD-2001-4/0 Purple P54 (2)	CD-920-4/0 Purple P54 (2)		
LCMA120 LCMD120 LCDN120	120mm ² Class 2r	- - 30.0	-	-	-	-	CD-2001-250 Yellow P62 (2)	CD-920-250 Yellow P62 (2)		
SCMS120										
LCMA150 LCMD150 LCDN150 SCMS150	150mm ² Class 2r	- - 30.0	-	-	-	-	CD-2001-300 White P66 (2)	CD-920-300 White P66 (2)		
LCMA185 LCMD185 SCMS185	185mm ² Class 2r	- - 32.0	-	-	-	-	CD-2001-400 Blue P76 (2)	CD-920-400 Blue P76 (2)		
LCMA240 LCMD240 SCMS240	240mm ² Class 2r	- - 37.5	-	-	-	-	CD-2001-500 Brown P87 (2)	CD-920-500 Brown P87 (2)		
LCMA300 LCMD300 SCMS300	300mm ² Class 2r	- - 39.0	-	-	-	-	-	CD-920-600 Green P94 (2)		
LCMAX300 LCMDX300 SCMSX300	375mm ² Class 2r	- - 49.0	-	-	-	-	-	-		
LCMA400 LCMD400 SCMS400	400mm ² Class 2r	- - 49.0	-	-	-	-	-	CD-920-750 CD-940-750** Black P106 (2)		
LCMA500 LCMD500 SCMS500	500mm ² Class 2r	- - 49.5	-	-	-	-	-	CD-940-1000** White P125 (3)		
LCMA630 LCMD630 SCMS630	630mm ² Class 2r	- - 67.0	-	-	-	-	-	CD-940-1000** White P125 (4)		
LCMA630 LCMD630	1000 kcmil Class G	- -	-	-	-	-	-	CD-940-750A** Red P125 (1) CD-940-1000** White P125 (2)		

For Instructions in Local Languages
and Technical Support:

techsupport@panduit.com



www.panduit.com

E-mail:
cs@panduit.com

Phone:
800-777-3300

Tool Chart for Compression Connectors Types LCMA, LCMD, LCMDN, and SCMS with Metric Class 2, 5, & 6 Copper Cable

Panduit Part No.		Wire Size & Class 5f,6f		Panduit Tool Part Number (For Class 5 & 6 Wire)											
				CT-100 (Manual)	CT-200 CT-1570 (Manual)	CT-600 (Air)	CT-1701 (Manual)	A See Tool List Below	B See Tool List Below	B See Tool List Below			Cembre Tool Part Number***		
				Die Pocket Number (Crimp Qty.)				Die Part Number Color & Die Index Number (Crimp Qty.)			Bottom Nest Die Part Number, Die Color, Index Number	Top Indentor Die Part Number, Die Index Number	Indenter (Crimp Qty.)		
LCMA2.5	1.5 - 2.5mm ² Class 5f Only	22-10 (1)	22-14 (1) 16-14 (1)	CT-570 16-14 (1)	P10 (1)	-	-	-	-	-	-	-	-	-	-
LCMA6 LCMD6	4 - 6mm ² Class 5f Only	22-10 (2)	12-10 (2)	CT-570 12-10 (2)	P10 (2)	-	-	-	-	-	-	-	-	-	-
LCMA10 LCMD10 SCMS10	10mm ² Class 5f Only	-	-	-	-	-	-	-	-	-	-	-	-	-	-
LCMA16 LCMD16 SCMS16	10mm ² Class 5f Class 6f	-	-	-	-	CD-2001-8 Red P21 (1)	CD-920-8 Red P21 (1)	CD-920-4 Gray P29	CDI-920-10 1	(1)	-	-	-	-	-
LCMA25 LCMD25	16mm ² Class 5f Class 6f	-	-	-	-	CD-2001-8 Red P21 (1)	CD-920-8 Red P21 (1)	CD-920-4 Gray P29	CDI-920-10 1	(1)	-	-	-	-	-
LCMA35 LCMD35 SCMS35	25mm ² Class 5f Class 6f	-	-	-	-	CD-2001-4 Gray P29 (1)	CD-920-4 Gray P29 (1)	CD-920-1/0 Pink P42	CDI-920-24 2	(1)	-	-	-	-	-
LCMA50 LCMD50 SCMS50	35mm ² Class 5f Class 6f	-	-	-	-	CD-2001-2 Brown P33 (2)	CD-920-2 Brown P33 (2)	CD-920-3/0 Orange P50	CDI-920-24 2	(1)	-	-	-	-	-
LCMA70 LCMD70 SCMS70	50mm ² Class 5f Class 6f	-	-	-	-	CD-2001-1 Green P37 (2)	CD-920-1 Green P37 (2)	CD-920-3/0 Orange P50	CDI-920-24 2	(1)	-	-	-	-	-
LCMA95 LCMD95 SCMS95	70mm ² Class 5f Class 6f	-	-	-	-	CD-2001-2/0 Black P45 (2)	CD-920-2/0 Black P45 (2)	CD-920-250 Yellow P62	CDI-920-48 4	(1)	-	-	-	-	-
LCMA120 LCMD120 LCMDN120 SCMS120	95mm ² Class 5f Class 6f	-	-	-	-	CD-2001-3/0 Orange P50 (2)	CD-920-3/0 Orange P50 (2)	CD-920-400 Blue P76	CDI-920-48 4	(1)	-	-	-	-	-
LCMA150 LCMD150 LCMDN150 SCMS150	120mm ² Class 5f Class 6f	-	-	-	-	-	-	CD-920-400 Blue P76	CDI-920-48 4	(1)	-	-	-	-	-
LCMA185 LCMD185 SCMS185	150mm ² Class 5f Class 6f	-	-	-	-	-	-	CD-920-400 Blue P76	CDI-920-48 4	(1)	-	-	-	-	-
LCMA240 LCMD240 SCMS240	185mm ² Class 5f Class 6f	-	-	-	-	-	-	CD-920-500 Brown P87	CDI-920-48 4	(1)	-	-	-	-	-
LCMA300 LCMD300 SCMS300	240mm ² Class 5f Class 6f	-	-	-	-	-	-	CD-920-750 Black P106	CDI-920-60 6	(1)	-	-	-	-	-
LCMAX300 LCMDX300 SCMSX300	300mm ² Class 5f Only	-	-	-	-	-	-	CD-920-300MX P32	CDI-920-60 6	(1)	-	-	-	-	-
LCMA400 LCMD400 SCMS400	-	-	-	-	-	-	-	-	-	-	-	-	-	-	-
LCMA500 LCMD500 SCMS500	-	-	-	-	-	-	-	-	-	-	-	-	-	-	-
LCMA630 LCMD630 SCMS630	-	-	-	-	-	-	-	-	-	-	-	-	-	-	-

A

CT-2001, CT-2001/L, CT-2001/LE, CT-2002, CT-2002/L, CT-3001, CT-3001/E, CT-3001/ST, CT-3001/STINT, CT-3001/STUK, CT-3001/STAUS, CT-3001/TO, CT-3001/CCP, CT-3001/CCPINT, CT-3001/CCPUK, CT-3001/CCPAUS, CT-3001/CCPTO

B

CT-920, CT-920/CV, CT-920CH, CT-920CH/CV, CT-920CH/CCP, CT-930, CT-930CH, CT-940CH*, CT-2920, CT-2920/CCP, CT-2920/CCPINT, CT-2920/CCPUK, CT-2920/CCPAUS, CT-2920/CCPTO, CT-2930, CT-2930/L, CT-2930/LE, CT-2931, CT-2931/ST, CT-2931/STINT, CT-2931/STUK, CT-2931/STAUS, CT-2931/TO, CT-2931/STCV, CT-2931/STCVINT, CT-2931/STCVUK, CT-2931/STCVAUS, CT-2931/CVTO, CT-2940*, CT-2940/L*, CT-2940/LE*, CT-2940/ST*, CT-2940/STINT*, CT-2940/STUK*, CT-2940/STAUS*, CT-2940/TO*

* CD-920 dies can be used with CT-940CH and CT-2940 tools with die adapter.

** CD-940 dies to be used exclusively with CT-940CH and CT-2940 tools.

*** Cembre tools used with Panduit CD-920 dies. Maximum splice size with Cembre tools is SCMS185.

± Maximum splice size is SCMS185, Maximum splice size SCMS400 with CT-2920/CCP AND CT-2920CH/CCP

For Instructions in Local Languages and Technical Support:

techsupport@panduit.com



www.panduit.com

E-mail: cs@panduit.com

Phone: 800-777-3300