

RG-NX Series - Nema 4X

Emergency Light Unit

IMPORTANT SAFEGUARDS

When using electrical equipment, basic safety precautions should always be followed including the following:

READ AND FOLLOW ALL SAFETY INSTRUCTIONS

1. Do not let power supply cords touch hot surfaces.
2. Do not mount near gas or electric heaters.
3. Use caution when handling batteries. Avoid possible shorting.
4. Equipment should be mounted in locations and at heights where it will not readily be subjected to tampering by unauthorized personnel.
5. The use of accessory equipment not recommended by the manufacturer may cause an unsafe condition.
6. Do not use this equipment for other than intended use.
7. All servicing should be performed by qualified service personnel.

SAVE THESE INSTRUCTIONS

Installation Instructions

1. Turn off unswitched AC power.
2. Open clear cover by removing the screws. Remove lamp protectors.
3. Remove the electronic module. Pull on the cover until snapping features disengage or use a screw driver by inserting it into the slots shown in figure 12 and prying the cover open.
4. Remove the battery in order to access the knockouts (k'out).
5. Install back plate:

Wall mounting on a junction (figure 2)

- a. Route unswitched AC circuit wires k'out into the junction box and leave 6" of wire length.
- b. Remove the k'outs needed to mount back plate. Considering the important weight of the unit, it's recommended to use key hole for additional securing. For Nexus option, install the the liquid tight fitting, provided with the unit, on the back plate. Use the k'out located on the top or bottom of the unit.
- c. Remove AC harness from electronic module. Wire to AC circuit wires using wire nuts (see figure 2). Refer to hookup instructions on page 2..

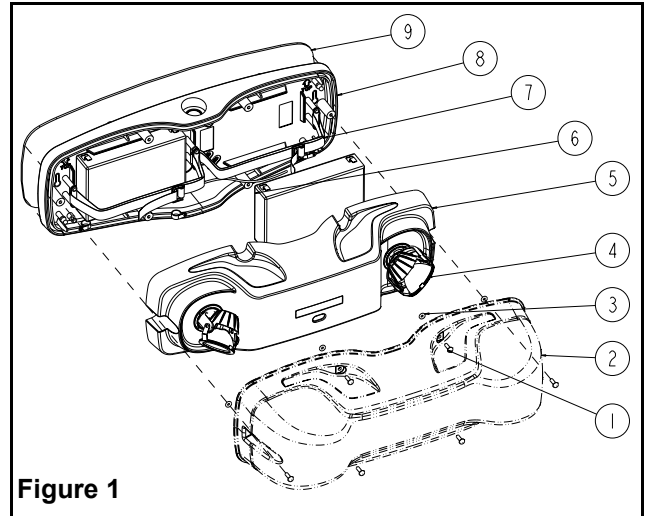

Figure 1

Part List

- | | |
|-----------------------------|---------------------------------|
| 1. Tamper-proof screws (6) | 9. Gasket |
| 2. Clear cover | 10. AC harness |
| 3. Gasket screw | 11. Ground wire |
| 4. Lamps | 12. Wire nut |
| 5. Electronic module | 13. J-box (not supplied) |
| 6. Battery | 14. J-box screws (not supplied) |
| 7. Battery strap or bracket | 15. Screw cover |
| 8. Backplate | |

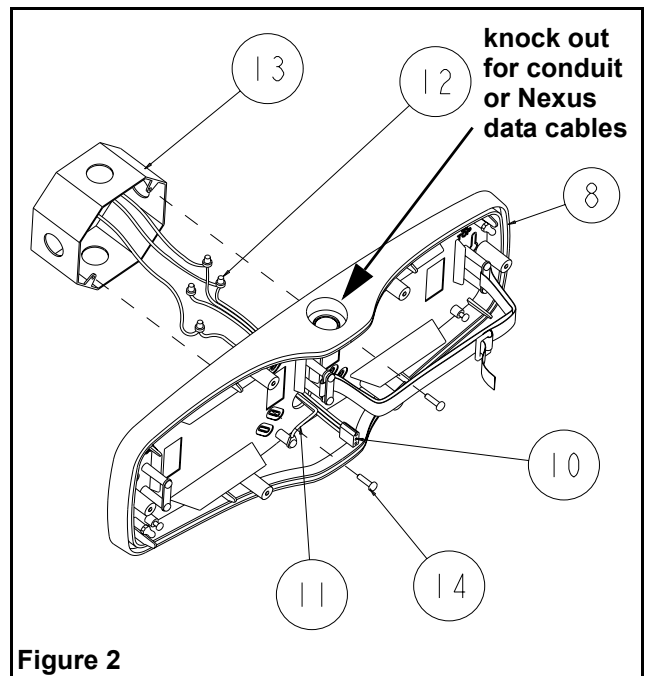

Figure 2

- d. Install the gasket on the back plate. Feed AC harness and the ground through the large hole in the backplate (see figure 2). Mount to J-box using the J-box screws (not provided). J-box should be properly secured directly to a stud.

Note: When back mounting the unit on uneven surface such as brick, silicone caulk should be used to prevent water from seeping in between the unit and the J-box.

Wall mounting with conduit

- Remove k'out on top of the backplate for conduit entry and key hole k'out to fix the backplate to the wall. For Nexus option, install the two holes liquid tight fitting, provided with the unit, on the bottom of the back plate. Don't route data cables with AC wires.
- Install a liquid tight conduit fitting on the backplate. Conduit size: 1/2" NPT (not provided).
- Install the unit on the wall using screws (not provided).
- Connect the conduit to fitting and route unswitched AC circuit wires in the unit.
- Remove AC harness from electronic module. Wire to AC circuit wires using wire nuts. Refer to hookup instructions..

Pole or I-beam mounting (Option)

- Universal bracket (part 16 on figure 4) is an accessory. Has to be ordered separately. Remove knockouts on top of the backplate for conduit entry.
 - Install a liquidtight conduit fitting on the backplate. Conduit size: 1/2" NPT.
 - Install the universal bracket as shown in figure 4. Don't install the gasket (9). This type of installation is not NSF certified for food processing areas.
 - Unit can be installed using steel banding for routing around the poles and I-beam. Standard banding 3/4" in width or less can be used (not provided). It can also be mounted on Superstrut® metal framing (1 5/8" channel series) using 1/4" bolt (not provided). Holes are placed at 9" apart horizontally.
 - Connect the conduit to fitting and route unswitched AC circuit wires in the unit.
 - Remove AC harness from electronic module. Wire to AC circuit wires using wire nuts. Refer to hookup instructions.
6. Complete electrical connection:

Standard product:

- Put batteries and electronic module back in place as shown on figure 5. See figure 6 for batteries wiring diagram.
- Connect transformer harness to AC harness.

Cold weather option:

- Connect battery heater (18) to thermostat (19) and to AC harness (10) (see figure 7).
- Refer to figure 8 for 120VAC input voltage and to figure 9 for 347VAC. Use wire taps provided with the hardware kit to connect battery heater. Unused wires must be insulated to prevent shorting.
- Put the batteries back in place . Battery heater is placed in between the battery and the backplate. See figure 6 for batteries

INSTRUCTIONS - HOOKUP

- 120 VAC OPERATION -

White wire - Common
Black wire - 120V Line
Green wire - Ground

-347 VAC OPERATION-

White wire - Common
Red wire - 347V Line
Green wire - Ground

Unused primary wire must be insulated to prevent shorting

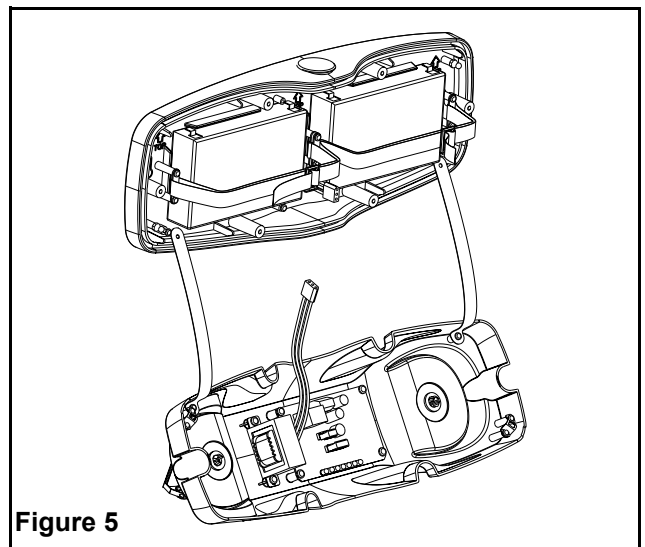
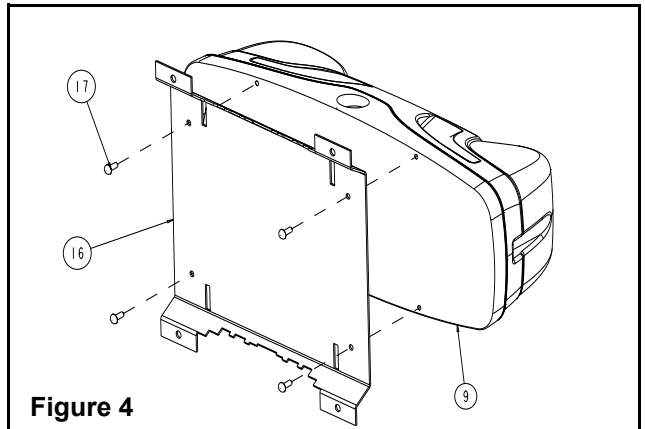
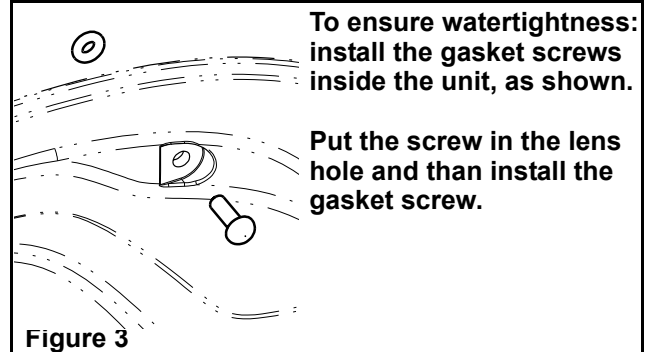

wiring diagram. Put the electronic module back in place as shown on figure 5.

d. Connect transformer harness to AC harness.

Nexus:

For connections related to Nexus system, refer to Nexus Addendum 750.1243.

7. For unit with remote capacity, connect remote heads to terminal block TB1 (see figure 11).
8. Snap electronic module on backplate.
9. Adjust lamp aiming.
10. Install the lens by using the 6 tamper-proof screws (1). To insure water tightness, gasket screws (x6) have to be installed from the inside (see figure 3). The screws should be equally torqued.
11. For food processing areas, in order to avoid food accumulation, screw caps have to be installed (provided with the hardware kit).
12. Energize AC. Lamps will turn on for few minutes.
13. See page 4 for testing procedure.

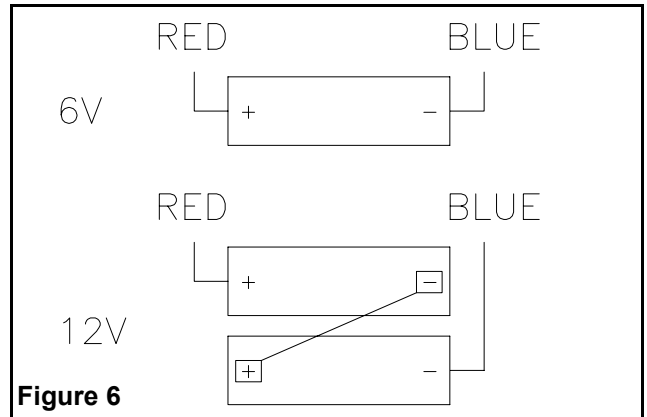

Figure 6

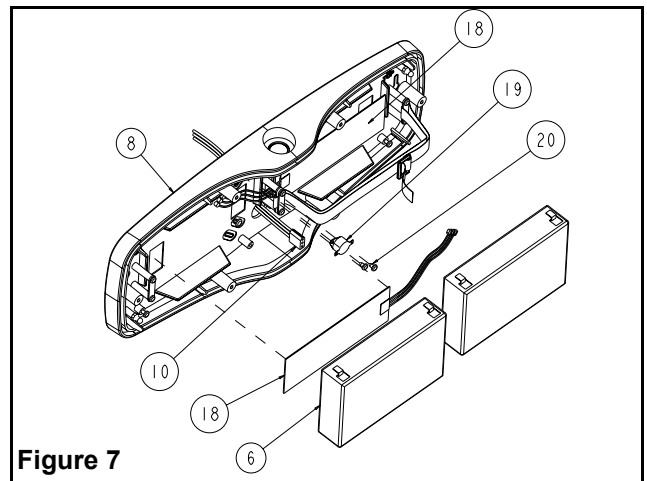

Figure 7

FOR COLD WEATHER OPTION ONLY

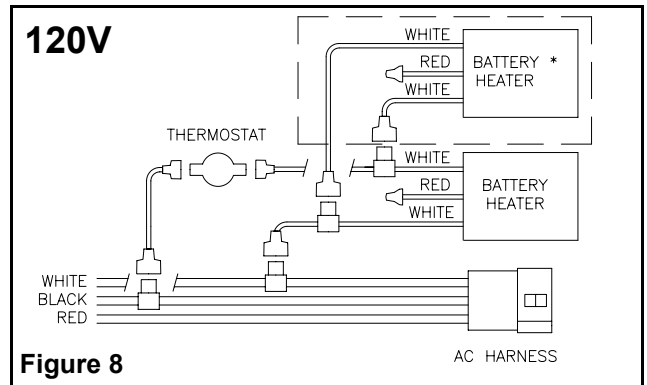

Figure 8

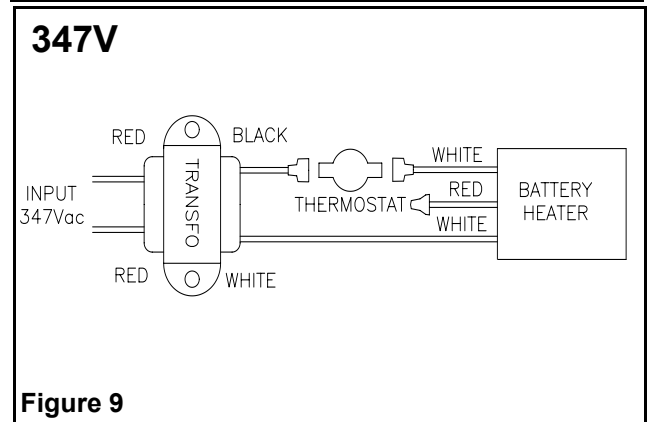

Figure 9

Manual Testing

Operate the magnetic “test switch” by holding the provided magnet near the AC pilot lamp, where indicated. This will initiate a one minute test. The DC lamps will illuminate for approximately one minute, then the unit will automatically return to stand by mode. Test can be cancelled by holding the magnet near the test switch again.

Automatic Testing (AD charger)

The unit will perform an automatic self-test of 1 minute every month, 10 minutes every 6 month and a 30 minutes self-test once a year.

Automatic Diagnostics (AD charger)

There are five diagnostic indicators: one external and four internal. Unit must be opened to gain access to internal indicators.

External: General alarm, “Service Required”. The LED will turn on if any alarm condition is detected (see figure 10).

Internal: Battery Failure, Battery Disconnect, Charger Failure & Lamp Failure. Steady ON if alarm condition exists. (see figure 11).

Normal operation, No fault — “Service Required” is OFF.

Faulty operation — “Service Required” is ON.

(See fig. 10).

See AD charger owner manual for more details.

Default setting

Unit is factory preset with a 10 minutes time delay and a non audible diagnostic. This setting can be changed to either turn off the time delay or turn on the audible diagnostic. See AD charger owner manual for more details.

NEXUS option

Unit equipment having the Nexus interface have 2 external indicators and 3 internal.

External: — (see figure 10)

AC ON (green): Illuminated when line voltage is present.

Nexus (tricolor LED): See Nexus Addendum for details.

Internal: See Nexus Addendum 750.1243 for details.

Food processing facilities

Screw covers are available in the hardware kit. These covers have to be installed on screws to avoid any food accumulation. Note: some detergent used in food processing industry can affect durability of Polycarbonate lens. Install unit on even wall surface to insure watertightness and avoid any gaps between the gasket and the wall.

Maintenance (All Models)

None required. If AC supply to the unit is to be disconnected for 2 months or more, the battery must be disconnecte.

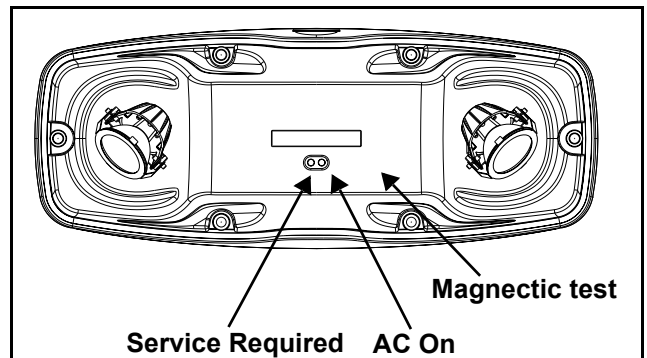

Figure 10

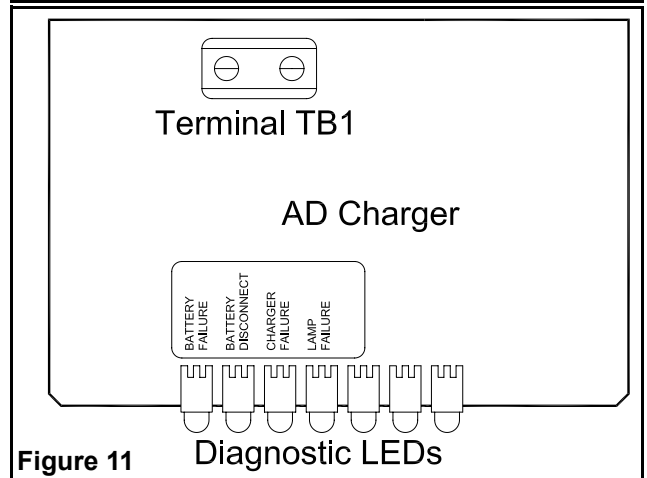

Figure 11

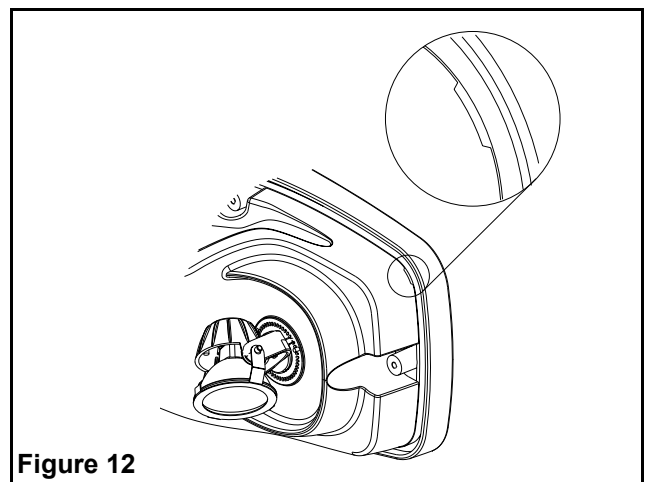

Figure 12

AD – Owner's manual

Advanced Diagnostic Flash Memory Charger Board

1. Installer

This manual must be turned over to owner on completion of installation. **WARNING:** Please RESET the system whenever you add or change lamp load. (refer to section 2.2)

IMPORTANT SAFEGUARDS

When using electrical equipment, basic safety precautions should always be followed including the following:

READ AND FOLLOW ALL SAFETY INSTRUCTIONS

1. Do not let power supply cords touch hot surfaces.
2. Do not mount near gas or electric heaters.
3. Use caution when handling batteries. Avoid possible shorting.
4. Equipment should be mounted in locations and at heights where it will not readily be subjected to tampering by unauthorized personnel.
5. The use of accessory equipment not recommended by the manufacturer may cause an unsafe condition.
6. Caution: If optional Halogen cycle lamp(s), symbol (H—), are used in this equipment, to avoid shattering: do not operate lamp in excess of rated voltage, protect lamp against abrasion and scratches and against liquids when lamp is operating, dispose of lamp with care.
7. Halogen cycle lamps operate at high temperatures. Do not store or place flammable materials near lamp.
8. Do not use this equipment for other than intended use.
9. All servicing should be performed by qualified service personnel.

SAVE THESE INSTRUCTIONS

2. Operation

The diagnostic/charger is a fully self-contained, fully automatic microcontroller based system.

The use of a high performance, 8 bit microcontroller enables us to provide the customer with one of the best charger/ diagnostic systems on the market. All operations are automatic and the installation is no more complicated than the procedure for a standard unit. When the installation is completed and the unit is powered, the system is automatically functional. There is no need to have the AC present at this time, only the battery needs to be connected. The unit goes directly in lockout mode and waits for AC to be restored.

The advanced diagnostic design is also based on field proven features that are well known for their high quality and reliability, such as the «PULSE PLUS» temperature compensated charger and the high quality sealed lead, lead-calcium, and NiCad batteries.

2.1 Standard features

2.1.1 General

High performance 8-bit microcontroller (MCU)
Lockout mode
Monthly and annual test sequence
Transfer delay

2.1.2 Charger

120/277 volts 60 Hz input standard
(120/347 in Canada)
Pulse charger under MCU control
Temperature compensated
Charger «ON» indicator lamp
AC «ON» pilot lamp
Damp Location listed (when specified)

2.1.3 Transfer

Sealed relay
Automatic and instantaneous
Low voltage battery disconnect
Fused output circuit
Brownout detection
Lockout

2.1.4 Diagnostic

Audible and non-audible version available
High efficiency red LED display
Battery failure
Battery disconnect
Charger failure
Lamp failure
Service alarm

2.2 System operation

The microcontroller provides decisional logic and output drivers for the monitoring and control of the battery, the charger, the lamp circuit, the LED strip, the transfer circuit, and all the alarm visual and audible indicators. Power line (AC) present indicator is also provided.

When an alarm is initiated, the audible warning, if enabled, is energized and the indicator associated with the fault is illuminated continuously. Alarms are acknowledged by pushing the «TEST» switch less than one half second. This action turns off the audible alarm and changes the alarm indicator status from continuous to intermittent (flashing). The Service Alarm can only be restored by correcting the fault or by a system re-initialization.

Re-setting the microcontroller is accomplished by removing all power sources, battery and AC power.

To activate the transfer, hold the provided magnet near the magnetic "test switch". The DC lamps will illuminate for approximately one minute, then the unit will automatically return to stand-by mode. The transfer can also be initiated by holding down the test button located on the board. The transfer can also be cancelled: hold the magnet near the switch or hold down the test button another time.

During a prolonged power outage, alarm status and lamp circuit data are memorized. When power is restored, all functions and alarm conditions resume operation in the same way they were before the power failure.

2.2.1 Charger

The charging circuit is a hysteresis type for lead-calcium batteries and 2-level trickle type for Ni-cad batteries.

2.2.1.1 Charger monitoring

The «CHARGER FAILURE» indicator is illuminated if the charging current does not fall within limits corresponding to the charger command state. The charger circuit parameters are pre-defined in the software and correspond to the battery type.

2.2.1.2 Battery monitoring (charger output)

2.2.1.2.1 Open battery circuit

The «BATTERY DISCONNECT» indicator is illuminated when any portion of the battery wiring has become open.

2.2.1.2.2 Battery failure

This is a multi-function indicator related to battery condition. This indicator will be illuminated when a wrong battery (ex: 6V battery on a 12V system or vice versa) or a completely depleted battery (battery voltage less than 65% of nominal) is connected to the circuit – Allow 24 hours recharging if the battery voltage is between 25% and 65% of nominal – it will also be illuminated if the battery has failed a timed or forced test (reached LVD level before the end of the test).

In the case of incorrect battery, the circuit will disable the charge current.

2.2.2 Lamp (incandescent only) and LEDs strip (combo unit only) Testing

Load (incandescent lamps and own LEDs strip) sampling and testing takes place only with a relatively charged battery, that is when the «CHARGER ON» LED is off for lead type battery and after 72 hours recharging or initial charging for NiCad batteries. When the unit is in test mode for the first time after installation, current samples, through the filament are stored and used as a reference for each subsequent test. The lamps are re-sampled annually if a lamp failure was not detected.

2.2.3 Transfer module

The transfer module consists mainly of a power relay. The transfer relay is activated by the MCU when there is a power failure, a brown-out condition or the test switch has been activated.

When a transfer is initiated (brown-out, manual test or auto-test), and the system fails to energize the lamp circuits, a system failure is detected and the «Service Alarm» indicator is illuminated.

3. Features

3.1 Automatic unit test (30-day test)

Every 30 days, while in charging mode, the sequence generator will generate a command to energize the transfer relay on the emergency lighting circuit for a certain duration.

The monthly test duration is one minute except for the 6th and the 12th month (see the table below). During the test period the charger is disabled and the charger monitoring functions are suspended.

Time period	US	Canada
monthly	one minute	one minute
6 th month	30 minutes	10 minutes
12 th month	90 minutes	30 minutes

Figure 1

If the battery fails to complete the discharge test, the «BATTERY FAILURE» indicator will be illuminated and the test aborted.

3.2 Transfer time delay (TD)

The Time Delay function (TD) is recommended when the battery unit is installed in areas normally illuminated by high-intensity discharge (HID) lamps, like: metal halide or high-pressure sodium lamps.

When enabled, the Standard Time Delay function maintains the emergency lights «ON» for 15 minutes (10 in Canada) after the AC main power is restored.

The Time Delay Function can be enabled or disabled in the field with the following procedure (see fig. 2):

- Make sure that the battery and the AC main power are both disconnected.
- Set the jumper JP7 as follows:

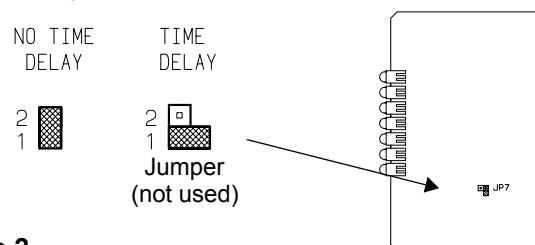

Figure 2

- Continue with the standard installation

3.2.1 Time delay duration

On request, the duration of the time delay can be set in the factory to another value: 5, 10, 15, 20 minutes. For ordering details, check the product catalogue.

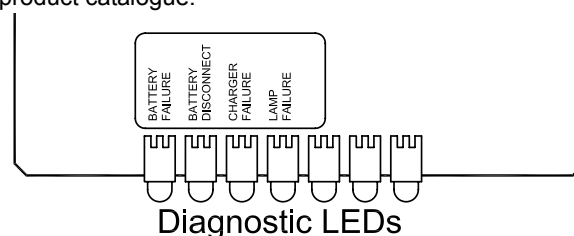

Figure 3

4. Equipment test display

Five high efficiency red LEDs for alarms (Indicates the failure diagnostic together with the Service Alarms), one yellow LED for CHARGER «on» and one green LED for AC «on».

4.1 Battery failure

When illuminated with Service Alarm indicator: Indicates a battery failure or incorrect battery voltage.

Action required: Replace battery

4.2 Battery disconnect

When illuminated with Service Alarm indicator: Indicates that there is no battery connected to the charger.

Action required: Connect the battery. Check terminals.

4.3 Charger failure

When illuminated with Service Alarm indicator: Indicates that there is a problem with the charger circuit.

Action required: Have the unit serviced.

4.4 Lamp failure

When illuminated with Service Alarm indicator: Indicates that there is one or more lamps defective. Flashing when loosing 50% or more LEDs.

Action required: Replace defective lamp(s), or LEDs strip.

4.5 Service alarm

When illuminated alone: indicates a malfunction of the transfer circuit.

Action required: Check the lamp circuit (are the lamps connected?), the fuse, replace if necessary.

4.6 AC ON (green)

Illuminated when line voltage is present.

4.7 Charger ON (Yellow)

Depending on the type of battery used and the charger level of the battery, the yellow LED may light in different ways:

Continuously ON: The battery is in full charge mode.

Flashing at a rate of one flash per second or less: Lead acid battery at end of charge.

Flashing continuously, approximately 10 flashes per second: NiCad or NiMH battery in trickle charge.

4.8 Test button

To activate the transfer, hold the provided magnet near the magnetic "test switch". It will initiate a 1 minute test. The test can also be initiated by holding down the test button located on the board.

The test can also be cancelled: hold the magnet near the switch or hold down the test button another time.

5. Electrical specifications

Power requirements

Standard:

120/277V 60Hz in US

120/347V 60Hz in Canada

Output: Fused output circuit

One lamp circuit, fused, 15 Amps

Transfer

Dust-tight relay automatically and instantaneously energizes lamp load upon failure of AC supply.

Lamp Failure resolution

10% of the nominal rated power or minimum 5 Watts, whichever is lighter.

Exit sign LED failure resolution (only for mini-system/ combo units)

Loss of 50% or more of LEDs (as per UL 924).

LVD

Low voltage battery disconnect automatically shuts down lamp load and circuitry when battery reaches approximately 87% of nominal battery voltage preventing deep discharge and permanent damage of the battery.

Lockout

Labor saving feature that automatically connects battery only after the AC circuit is activated. This feature allows the installer to connect the battery prior to having the AC circuit activated.

Brownout

This feature initiates a transfer when the input line voltage dips below 70-80% of nominal voltage (power loss).

Charger

The charger is current limited, temperature compensated and short-circuit proof. The equipment is capable of full recharge in compliance with Underwriters Laboratories Std. 924 specifications, and CSA C22.2 no. 141.

Controls

One external test switch.

Voltage drop protection

When remote fixtures and exit signs are connected to emergency lighting units of less than 50 volts, circuit runs must be sufficient size to maintain a proper operating voltage to all lamps. The maximum allowable voltage drop should not exceed 5%. Proper wire size can be selected from the following table (see fig. 4) or by use of the following formula

$$CM = \frac{22 \times W \times L}{.05 \times E^2}$$

CM = Wire size in circular mills

W = Emergency load in watts

L = Length of circuit in feet

E = Line Voltage

22 = Constant

.05 = Factor for max. allowable voltage drop

	Wire size	LENGTH OF WIRE RUN (in feet)													
		Watts													
		13	18	25	30	35	50	60	75	100	150	200	250	300	400
6 VOLT	12	41	30	21	18	15	11	9	8	6	4	---	---	---	---
	10	65	47	32	28	24	17	14	11	9	6	---	---	---	---
	8	110	75	54	45	39	27	22	18	14	9	7	---	---	---
	6	165	120	86	71	62	43	36	29	22	15	11	9	---	---
12 VOLT	12	165	110	85	71	61	42	35	29	21	14	10	8	---	---
	10	260	190	136	112	97	68	52	45	34	23	17	14	11	---
	8	415	300	215	180	154	108	90	72	54	36	27	21	18	---
	6	660	475	340	285	245	170	140	114	86	57	43	34	28	---
	4	1050	760	540	455	390	275	225	182	137	91	68	55	45	---
24 VOLT	12	660	440	340	284	244	168	140	116	84	56	40	32	26	21
	10	1040	760	544	448	388	272	208	180	136	92	68	52	44	34
	8	1668	1200	860	720	616	432	360	288	216	144	108	84	72	54
	6	2640	1900	1360	1140	980	680	560	456	344	228	172	136	112	85
	4	4200	3040	2160	1810	1560	1100	900	728	548	364	272	220	180	100
32 VOLT	12	1160	840	600	500	435	300	250	200	150	100	75	60	50	42
	10	---	1340	960	800	690	480	400	320	240	160	120	96	80	63
	8	---	---	1540	1280	1110	770	640	510	385	255	192	154	128	100
	6	---	---	---	---	1740	1220	1020	815	610	405	305	240	200	163
	4	---	---	---	---	---	---	1620	1300	970	650	485	390	325	260
48 VOLT	12	---	1899	1367	1139	949	680	---	455	341	227	170	136	113	68
	10	---	---	---	1811	1509	1085	---	724	543	362	271	217	181	108
	8	---	---	---	---	---	1729	---	1152	864	576	432	345	288	172
	6	---	---	---	---	---	---	---	1832	1374	916	687	549	458	274
120 VOLT	12	14964	10839	7792	---	---	3896	---	---	1945	1300	977	720	650	608
	10	23787	17230	12367	---	---	6193	---	---	3093	2067	1553	1238	1033	966
	8	37810	27410	19705	---	---	9852	---	---	4820	3289	2471	1970	1644	1538
	6	60159	43570	31327	---	---	15663	---	---	7822	5229	3929	3132	2614	2445

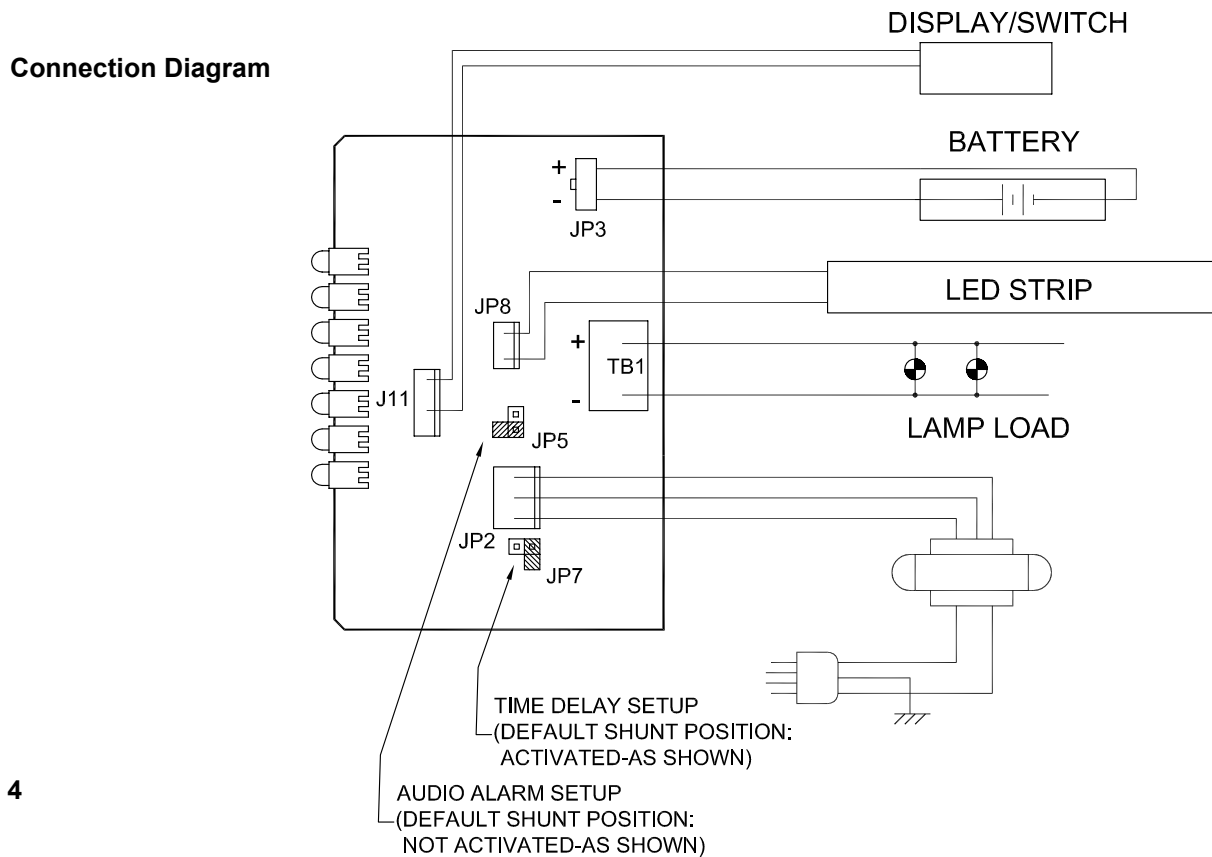

Figure 4