

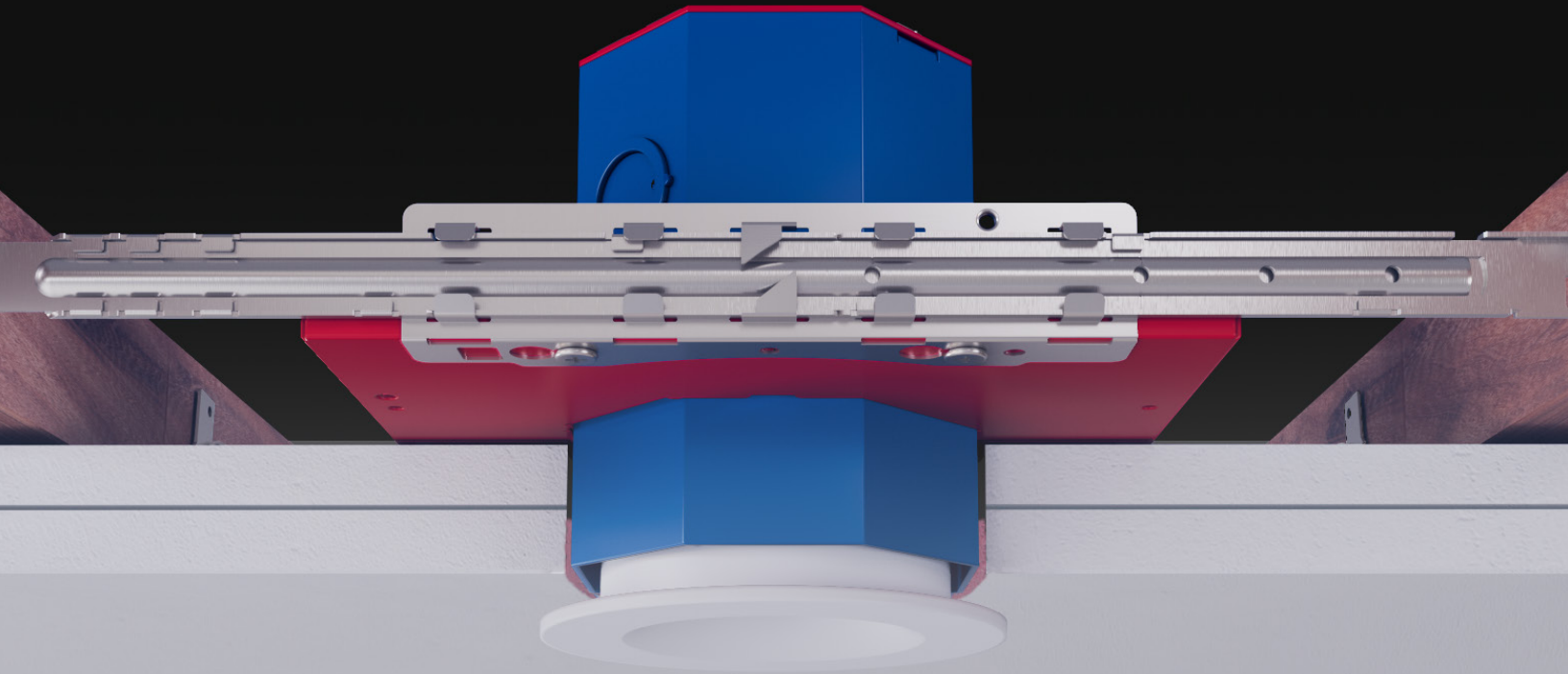

2 Hour
Fire Rated Protection



SAFETY WITHOUT COMPROMISE

The LUNA Fire is engineered to provide high quality optics while maintaining compliance to strict fire and building codes. Boasting 1000 delivered lumens, two beam angles, Dim-to-Warm and selectable color temperature, this luminaire provides the high-quality optics expected from the LUNA family. Uniquely, this product is designed to maintain a fire-rated ceiling by creating a contained unit above the ceiling that can be smoke caulked from below preventing air passage. Once installed and sealed the driver and electrical connections remain accessible from below. This ensures that the LUNA fire meets fire codes and building codes simultaneously.



MAINTAINING A FIRE BARRIER AND ACCESS TO ELECTRICAL CONNECTIONS

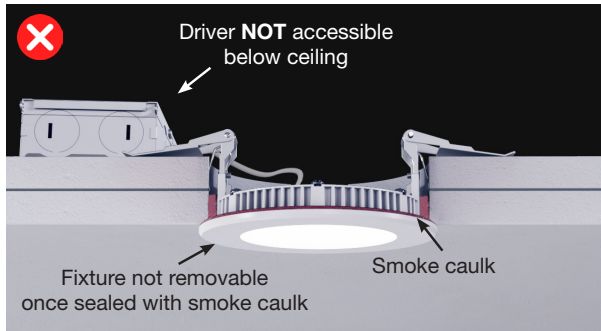

Fixture is smoke caulked, but no longer allows access to electrical connections below the ceiling.

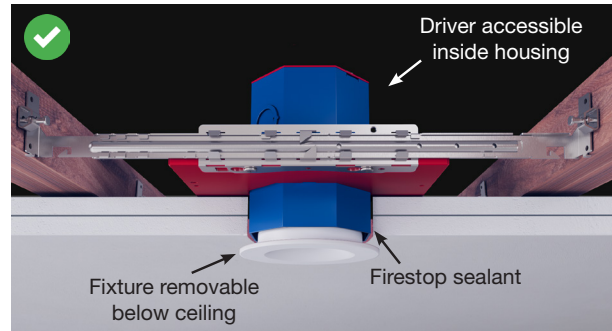

LUNA Fire maintains a fire barrier and allows for access to driver and electrical connections below the ceiling. Firestop sealant added between housing and ceiling only.

LUNA FIRE



Experience the brilliance of LUNA Fire, the ultimate fire-rated lighting solution that seamlessly combines high-quality optics with unparalleled safety. With two stylish trim options including regressed and trumpet, LUNA Fire effortlessly enhances any space while prioritizing your well-being.

DELIVERED

750 lm (9W)
1000 lm (12W)

TRIM FINISH

WHITE (WH) BLACK (BK)

BEAM ANGLE

20° 40°

TRIM

3.5"
ROUND
TRUMPET &
DESIGNER
REGRESSED

COLOR TEMPERATURE

CCT5
Selectable Dim-to-Warm
27, 30, 35,
40, 50 K

FEATURES

- 2-hour fire rating
- Driver: 120-277V, TRIAC/ELV, 0-10V dimming
- Approved for direct contact with insulation
- Rigid hanger bars extend from 12"-25"
- Accommodates ceiling thickness up to 2"
- Fixture and driver accessible from below the ceiling
- Suitable for wet locations

RATINGS

- UL 1598 / CSA C22.2#250.0 - Type IC / Non-IC
- UL 263 / ULC-S101 - Building Construction Material
- UL 2108 - Low Voltage Lighting
- CSA C22.2 #250.2
- ASTM E283 - Air Tight
- ASTM E119

