

cam -lok[®]
ASSEMBLY INSTRUCTIONS
Series E1016 & E1018

**NOTE: USE COPPER (CU)
CONDUCTORS ONLY.**

1. MEASURE CABLE JACKET.

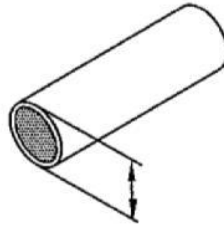

2. CUT SLEEVE TO MATCH.



3. SLIDE ONTO CABLE.

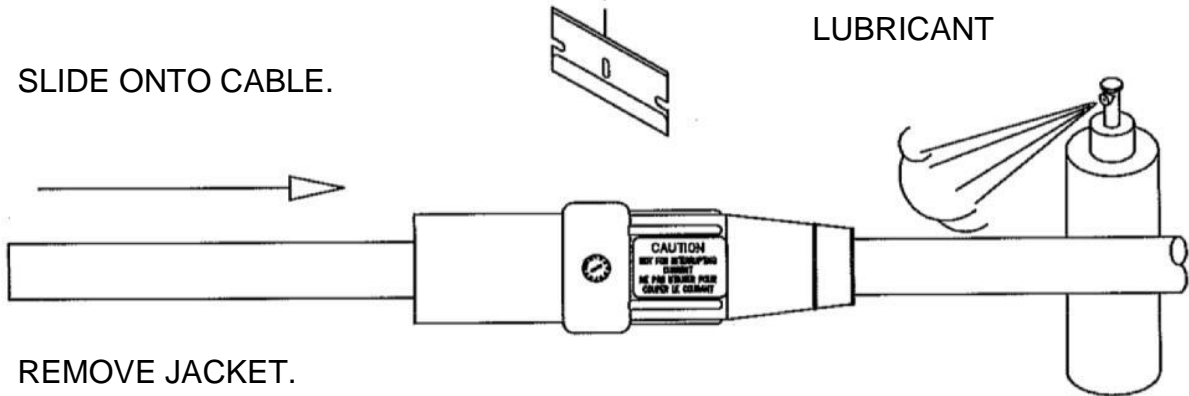

4. REMOVE JACKET.

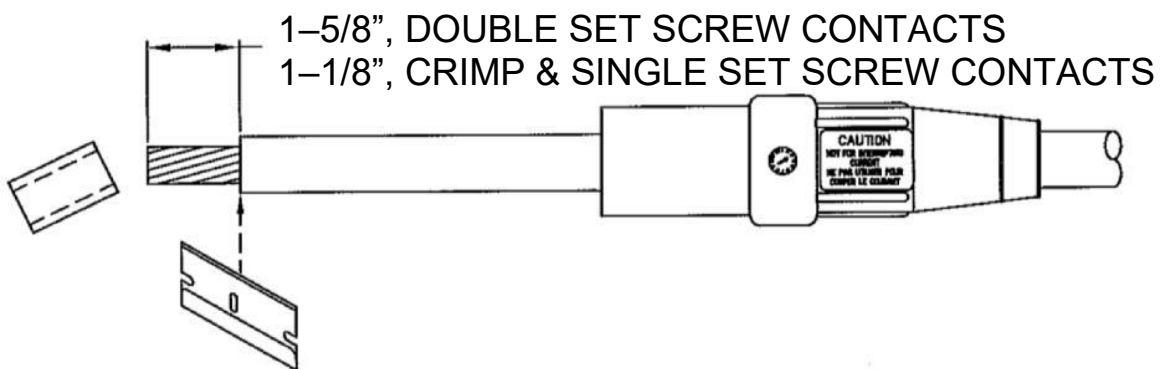

5. WRAP COPPER SHIM.

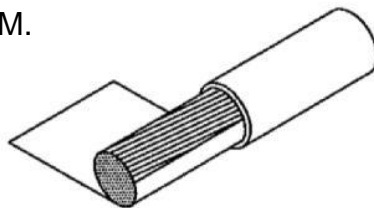

NOTE: USE TWO SHIMS FOR
#2-1/0 CABLE, AND ONE
SHIM FOR 2/0-4/0 CABLE.

ASSEMBLY INSTRUCTIONS

Series E1016 & E1018

6. WRAP STRAIN RELIEF WIRE.

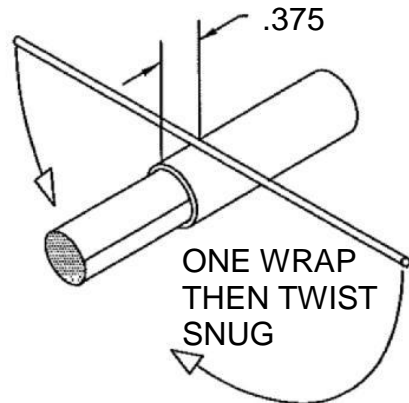
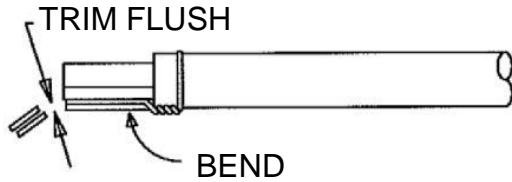

7. INSERT INTO CONTACT.

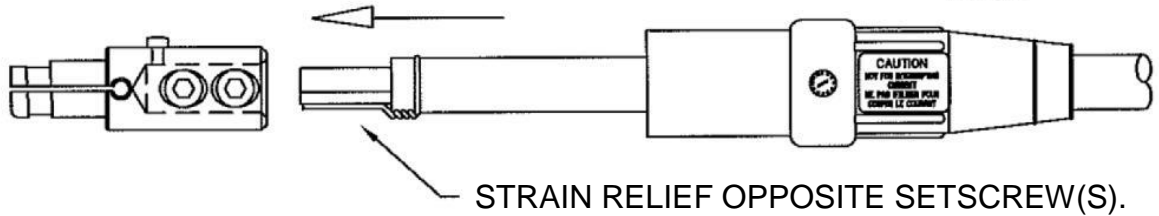

8A. TIGHTEN SETSCREW(S).

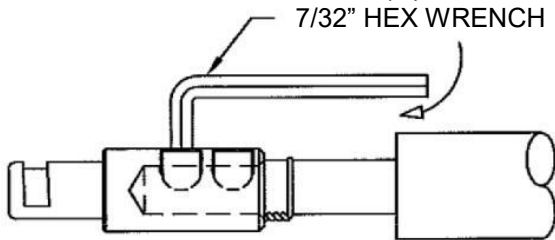

CABLE SIZE	TORQUE INCH POUNDS
#2-#1	100
1/0-2/0	120
3/0-4/0	220

OR

8B. CRIMP CONTACT

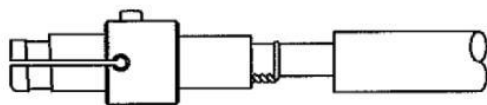

CABLE SIZE	CRIMP NEST	CRIMP PRESS
#2-#1	100514-3	A200914-3
1/0-2/0	100514-4	A200914-4
3/0	100514-5	A200914-5
4/0	100514-6	A200914-6

9. LUBRICATE CONTACT.

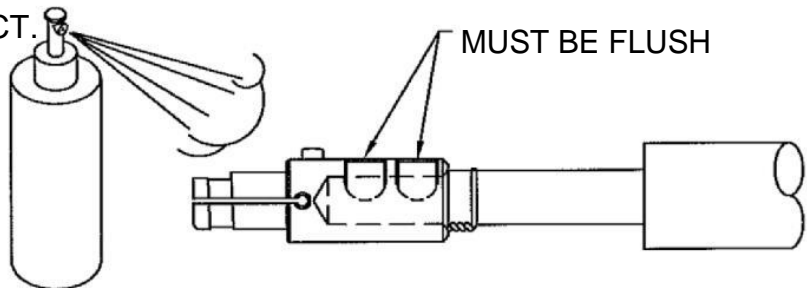

cam -lok[®]

ASSEMBLY INSTRUCTIONS

Series E1016 & E1018

10. LINE UP PIN WITH ARROW.

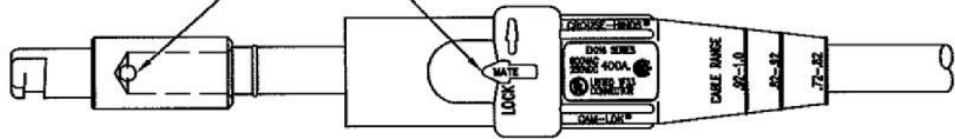

11. PUSH SLEEVE OVER CONTACT.

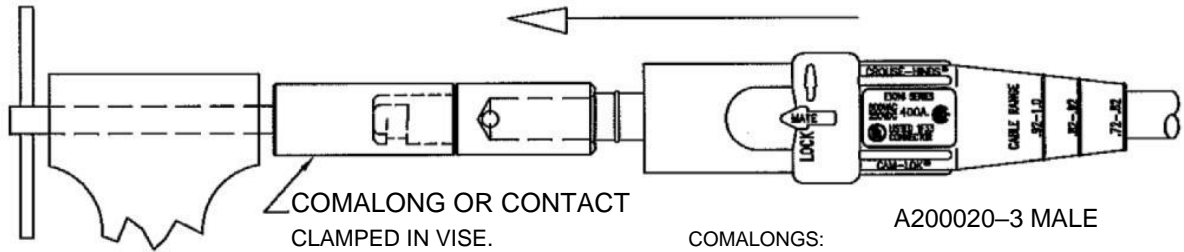

12. PIN MUST POP INTO POCKET.

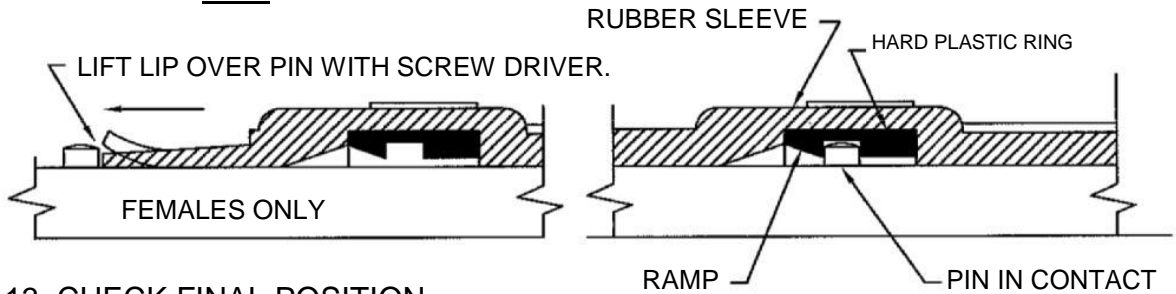

13. CHECK FINAL POSITION.

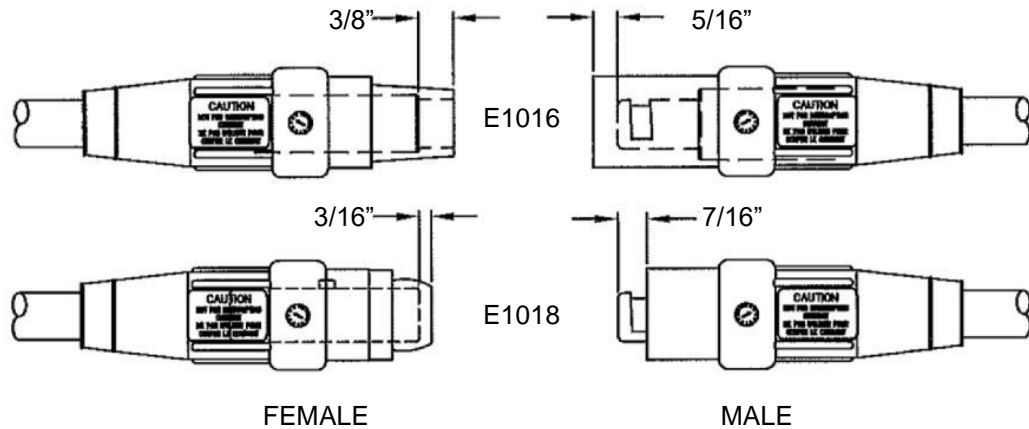

cam -lok[®]
ASSEMBLY INSTRUCTIONS
Series E1016 & E1018

SLEEVE REMOVAL PROCEDURE

1. MATE WITH COMALONG OR CONTACT.

COMALONGS: A200020-3 MALE
A200020-4 FEMALE

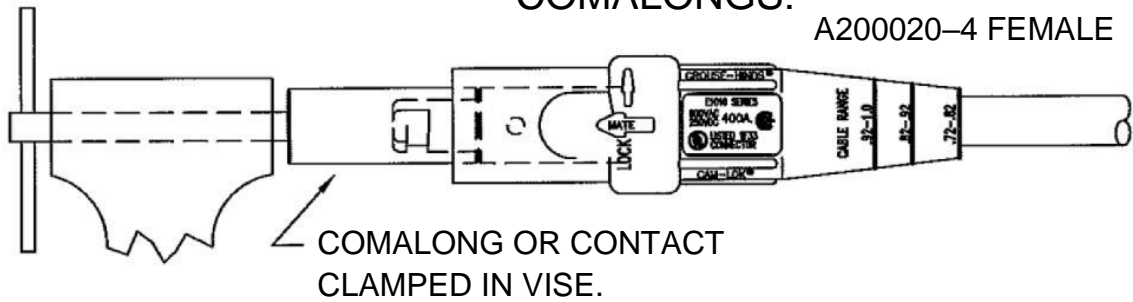

2. INSERT 1/4" WIDE SCREW-DRIVER INTO KEYWAY.

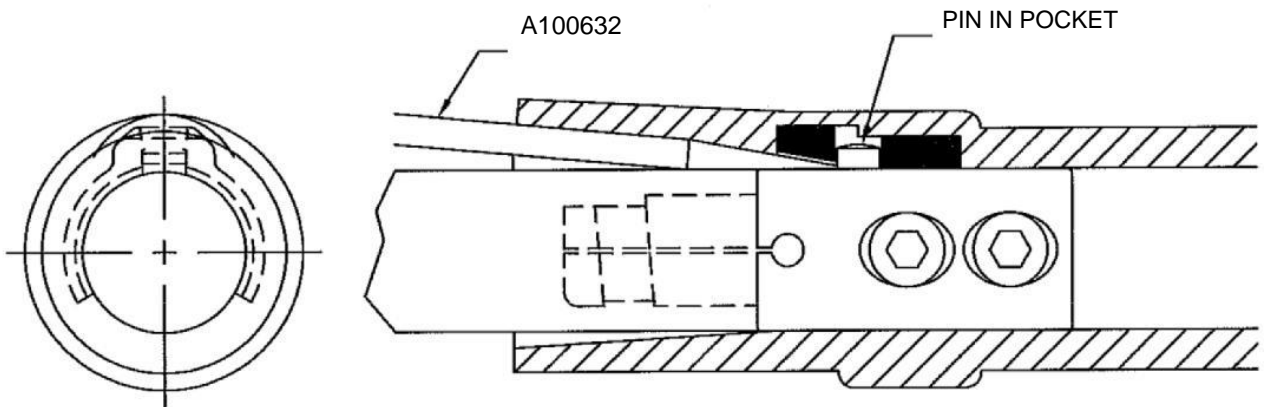

3. ROTATE BLADE 90° TO LIFT RING OFF PIN.

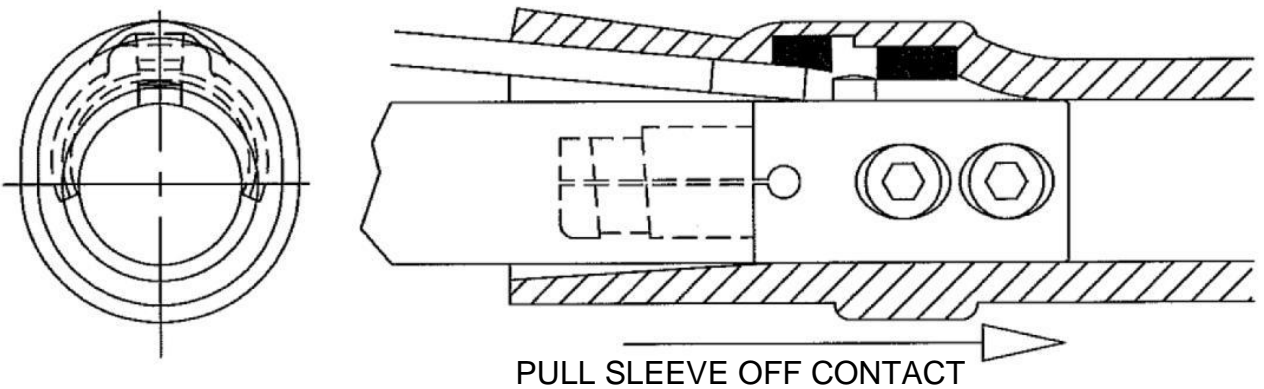

cam -lok[®]

ASSEMBLY INSTRUCTIONS

Series E1016 & E1018

CONTACT AND CONDUCTOR SIZE INFORMATION

Series	Style	Conductor Size	Continuous Amp Rating	Conductor Entrance Diameter	Contact	
					Male	Female
E1016	CRIMP	#2-#1	170	.402	A200036-18	A200037-23
E1016	CRIMP	1/0-2/0	235	.495	A200036-19	A200037-24
E1016	CRIMP	1/0-2/0 HD	235	.495	A200038-11B	A200035-17B
E1016	CRIMP	3/0-4/0	315	.620	A200038-6B	A200035-14B
E1016	SINGLE SET SCREW	#2-2/0	235	.578	A200065-1	A200067-3
E1016	SINGLE SET SCREW	3/0-4/0	315	.656	A200064-1	A200090-1
E1016	DOUBLE SET SCREW	#2-2/0	300	.578	A200630-1	A200640-3
E1016	DOUBLE SET SCREW	3/0-4/0	400	.656	A200639-1	A200641-1
E1018	CRIMP	#2-#1	170	.402	A200036-2	A200037-6
E1018	CRIMP	1/0-2/0	235	.495	A200036-3	A200037-7
E1018	CRIMP	3/0-4/0	400	.620	A200038-2	A200035-4

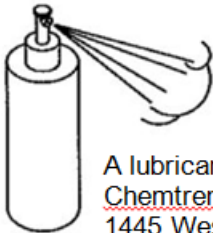

A lubricant is available from:
Chemtrend, Inc.
 1445 West McPherson Park Drive
 Howell, Michigan 48844-0860
 Their part number is CT-39F.

For high volume or frequent installation, use the Lektralink assembly tool as shown below. The part number is A400001. Complete instructions for use are included with tool.

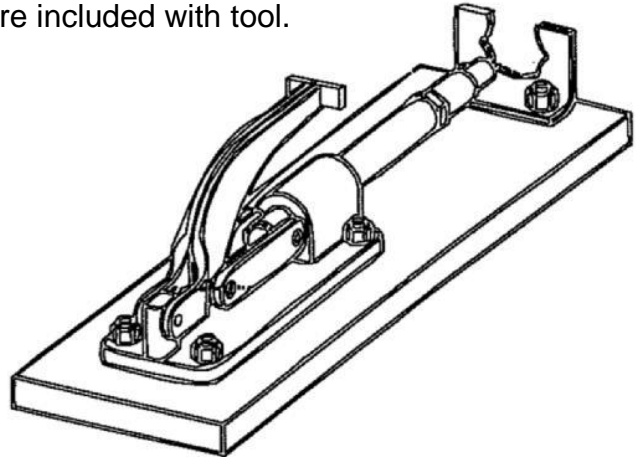

Eaton.com/recycling

EAT•N CROUSE-HINDS
 SERIES

Crouse-Hinds Molded Products

UNITED STATES:

4758 Washington Street • LaGrange, North Carolina 28551
 Phone (252) 566-3014 • FSCM-90129 • FAX (252) 566-9337

CANADA:

Crouse-Hinds Canada, Ltd.
 5925 McLaughlin Road • Mississauga, Ontario L5R 1B8

cam-lok[®]
INSTRUCTIONS DE MONTAGE
Séries E1016 et E1018

REMARQUE : UTILISER DES CONDUCTEURS EN CUIVRE (CU) SEULEMENT. (CU) SEULEMENT.

1. MESURER LA GAINÉ DU CÂBLE.

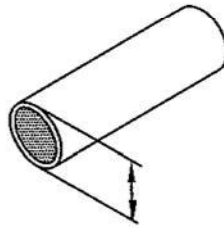

2. COUPER LE MANCHON AU BON DIAMÈTRE.



3. FAIRE GLISSER SUR LE CÂBLE.

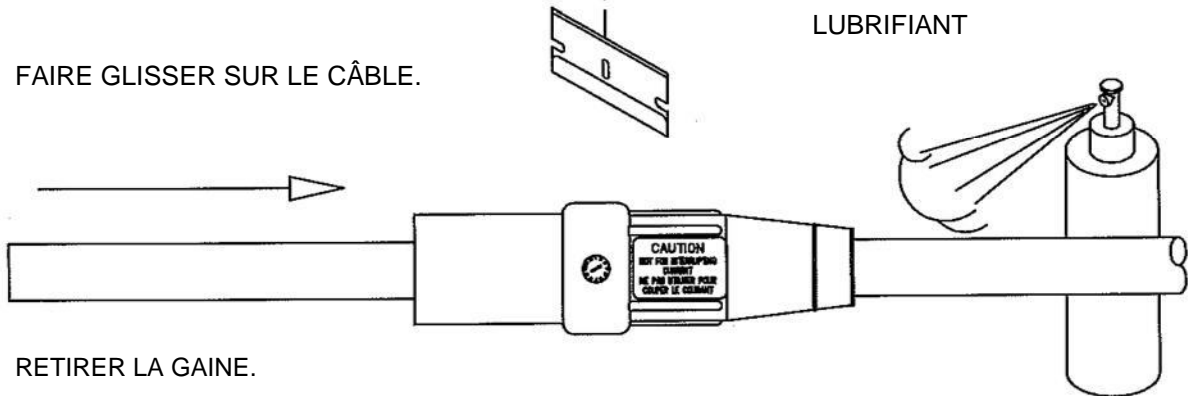

4. RETIRER LA GAINÉ.

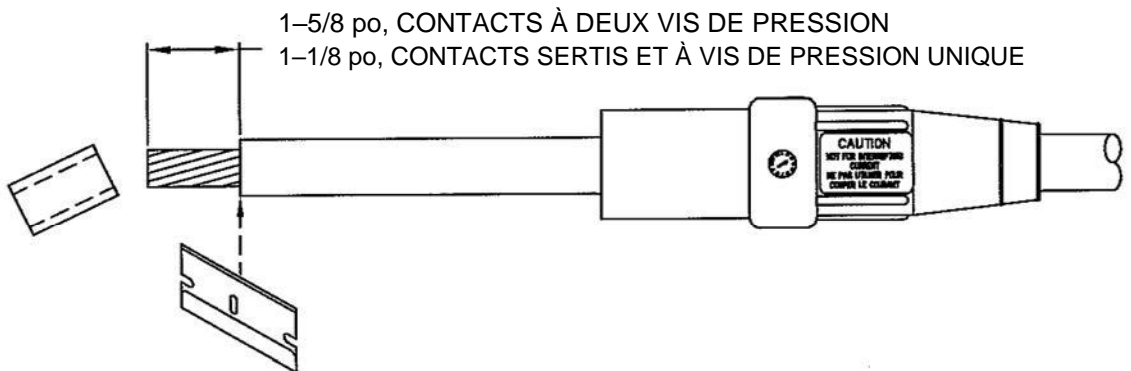

5. ENROULER UNE CALE EN CUIVRE.

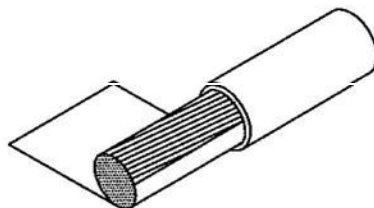

REMARQUE : UTILISER DEUX CALES POUR UN CÂBLE 2-1/0 ET UNE CALE POUR UN CÂBLE 2/0-4/0.

cam-lok[®]

INSTRUCTIONS DE MONTAGE

Séries E1016 et E1018

EB 9

Page 2

6. ENROULER UN FIL ANTITRACTION.

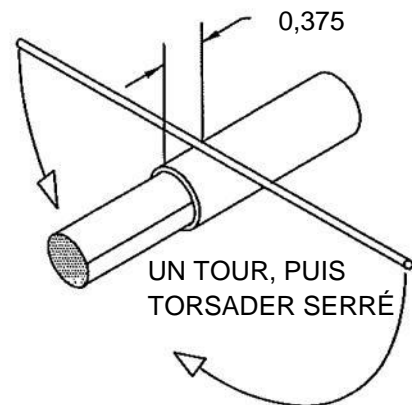
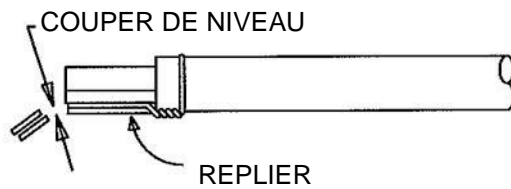

7. INSÉRER DANS LE CONTACT.

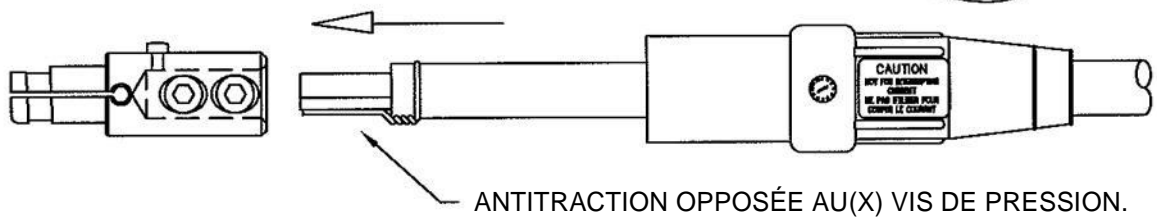

8A. SERRER LA (LES) VIS DE PRESSION

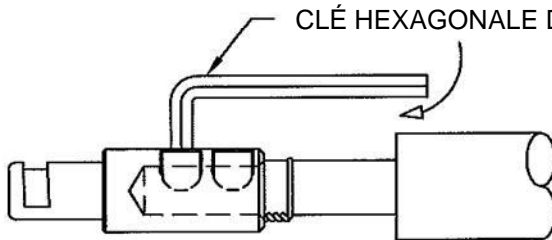

CALIBRE DU CÂBLE	COUPLE EN POUCES- LIVRES
2-1	100
1/0-2/0	120
3/0-4/0	220

OU

8B. CONTACT SERTI

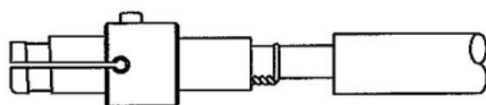

CALIBRE DU CÂBLE	NID DE SERTISSAGE	PRESSE À SERTIR
2-1	100514-3	A200914-3
1/0-2/0	100514-4	A200914-4
3/0	100514-5	A200914-5
4/0	100514-6	A200914-6

9. LUBRIFIER LE CONTACT.

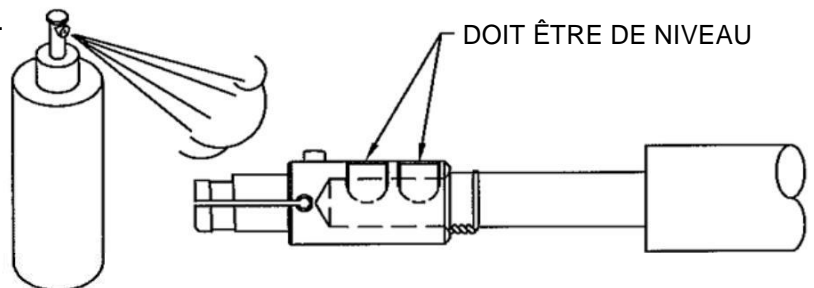

cam-lok[®]

INSTRUCTIONS DE MONTAGE

Séries E1016 et E1018

EB 9

Page 3

10. ALIGNER LA GOUPILLE AVEC LA FLÈCHE.

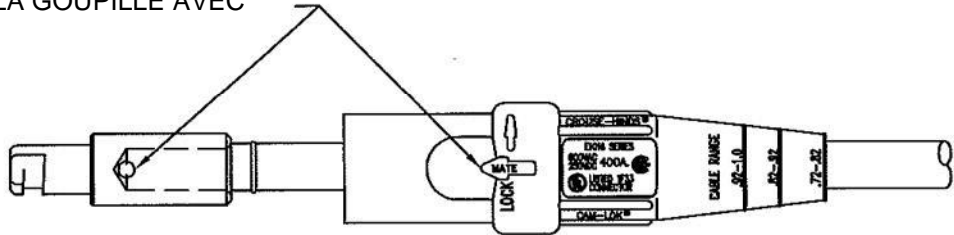

11. POUSSER LE MANCHON SUR LE CONTACT.

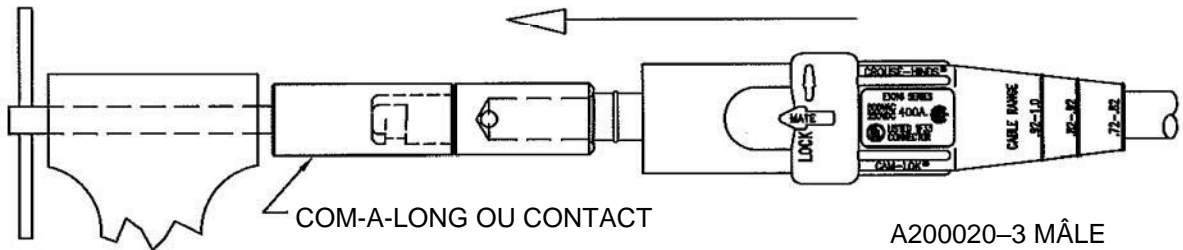

FIXÉ DANS UN ÉTAU.

A200020-3 MÂLE

COM-A-LONG : A200020-4 FEMELLE

12. LA GOUPILLE DOIT ENTRER DANS UNE POCHE.

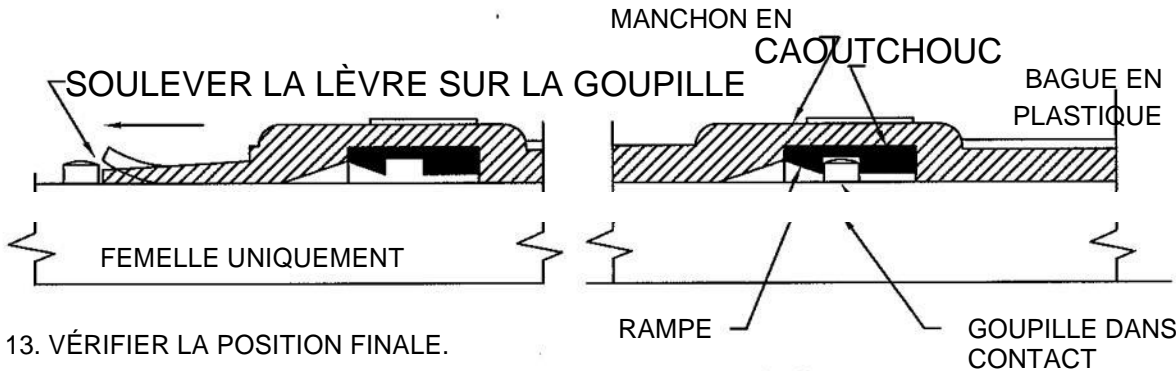

FEMELLE UNIQUEMENT

13. VÉRIFIER LA POSITION FINALE.

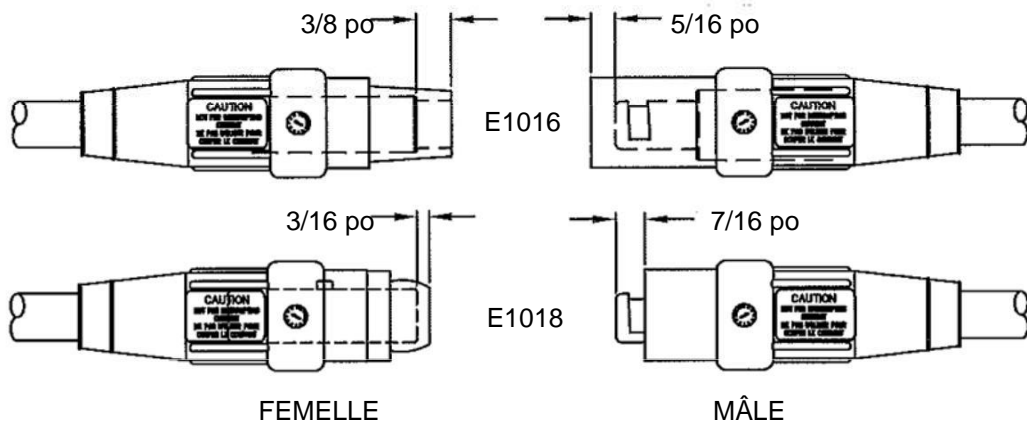

cam -lok[®]
INSTRUCTIONS DE MONTAGE
Séries E1016 et E1018

PROCÉDURE DE RETRAIT DU MANCHON

1. APPARIER AVEC UN COM-A-LONG OU UN CONTACT.

COM-A-LONG :

A200020-3 MÂLE

A200020-4 FEMELLE

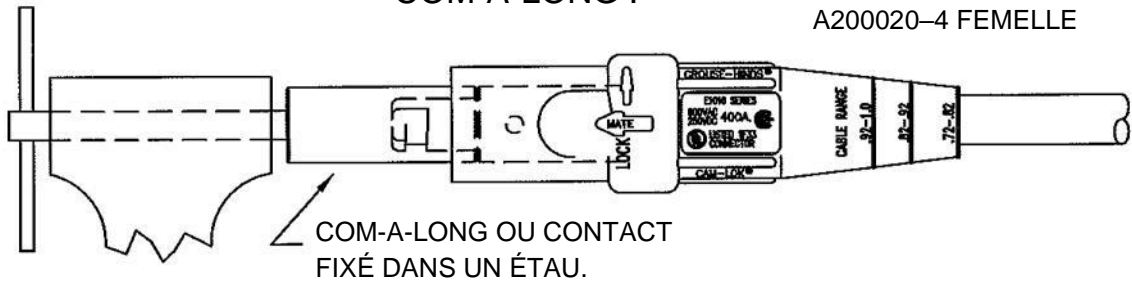

2. INSÉRER UN TOURNEVIS DE 1/4 po DANS LA RAINURE.

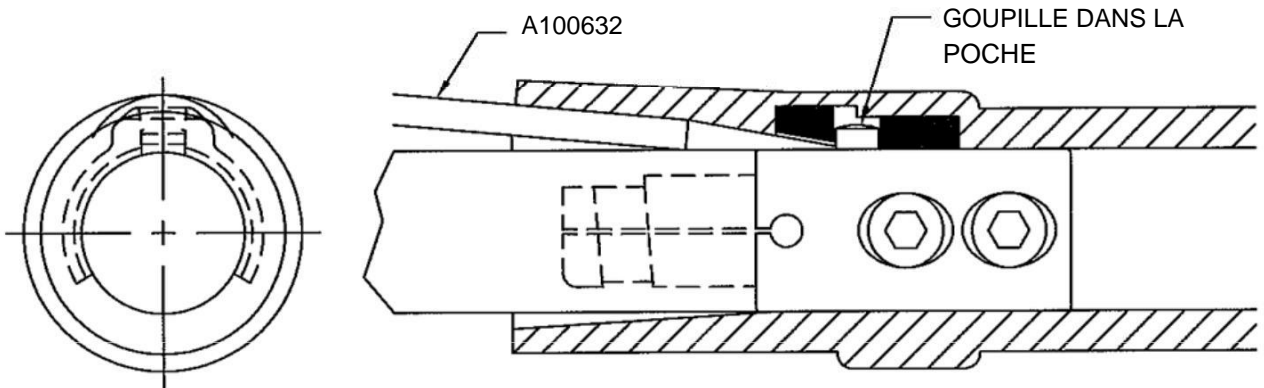

3. TOURNER LA LAME DE 90° POUR SOULEVER LA BAGUE HORS DE LA GOUPILLE.

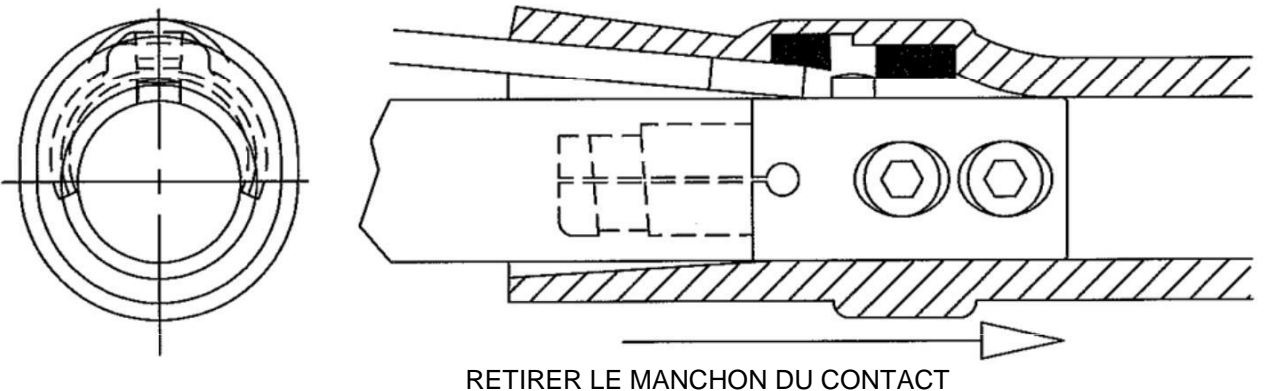

cam -lok[®]
INSTRUCTIONS DE MONTAGE
 Séries E1016 et E1018

EB 9

Page 5

RENSEIGNEMENTS SUR LES CONTACTS ET LE CALIBRE

Série	Style	Calibre du conducteur	Intensité nominale en régime permanent	Diamètre de l'entrée du conducteur	Contact	
					Mâle	Femelle
E1016	SERTI	2-1	170	0,402	A200036-18	A200037-23
E1016	SERTI	1/0-2/0	235	0,495	A200036-19	A200037-24
E1016	SERTI	1/0-2/0 HD	235	0,495	A200038-11B	A200035-17B
E1016	SERTI	3/0-4/0	315	0,620	A200038-6B	A200035-14B
E1016	VIS DE PRESSION UNIQUE	2-2/0	235	0,578	A200065-1	A200067-3
E1016	VIS DE PRESSION UNIQUE	3/0-4/0	315	0,656	A200064-1	A200090-1
E1016	VIS DE PRESSION DOUBLE	2-2/0	300	0,578	A200630-1	A200640-3
E1016	VIS DE PRESSION DOUBLE	3/0-4/0	400	0,656	A200639-1	A200641-1
E1018	SERTI	2-1	170	0,402	A200036-2	A200037-6
E1018	SERTI	1/0-2/0	235	0,495	A200036-3	A200037-7
E1018	SERTI	3/0-4/0	400	0,620	A200038-2	A200035-4

Pour un grand volume ou des installations fréquentes, utiliser l'outil de montage Lektralink illustré ci-dessous. Son numéro de pièce est A400001. Des instructions complètes relatives à son utilisation sont incluses avec l'outil.



Un lubrifiant est offert par :
 Chemtrend, Inc.
 1445 West McPherson Park Drive
 Howell, Michigan 48844-0860
 Son numéro de pièce est CT-39F.

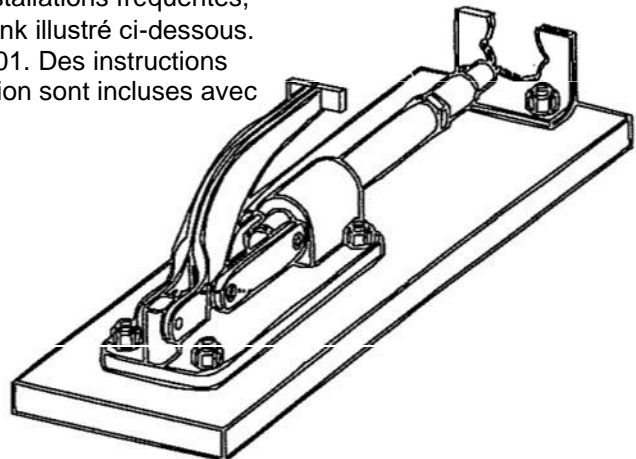

Eaton.com/recycling

EATON CROUSE-HINDS
 SERIES

Crouse-Hinds Molded Products

ÉTATS-UNIS
 4758 Washington Street • LaGrange, North Carolina 28551
 Téléphone : (252) 566-3014 • FSCM-90129 • Télécopieur : (252) 566-9337

CANADA
 Crouse-Hinds Canada. Ltd.
 5925 McLaughlin Road • Mississauga, Ontario L5R 1B8
 Téléphone : (905) 507-4187 • Télécopieur : (905) 501-4076