

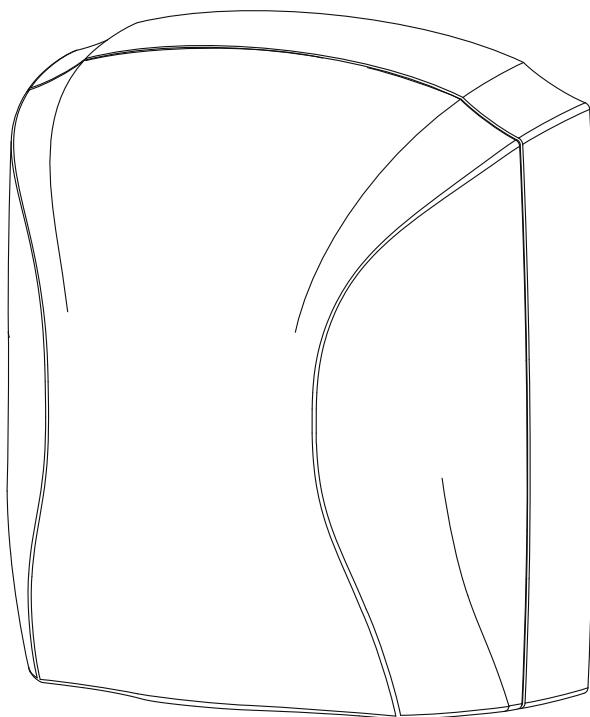

INSTALLER'S GUIDE

EL-NIÑO HAND DRYER

REPLACEMENT COMPONENT LIST INCLUDED



This unit
complies with
UL standards

WARNING

Before installing and operating this product, the user and/or installer must read, understand and follow these instructions and keep them handy for future reference. If these instructions are not followed, the warranty will be considered null and void and the manufacturer deems no further responsibility for this product.

This product must be installed by a qualified person and connected by a **certified electrician**, according to the electrical and **building codes** effective in your region.

The following instructions must be adhered to in order to avoid personal injuries or property damages, serious injuries and potentially fatal electric shocks.

Protect the heating unit with the appropriate circuit breaker or fuse, in accordance with the nameplate.

Make sure the line voltage (volt) is consistent with that indicated on the unit's nameplate.

This unit must be **grounded**.

Switch off the power at the circuit breaker/fuse before installing, repairing and cleaning the unit.

Make sure the unit is appropriate for the intended use (if needed, refer to the product catalog or a representative).

Do not install the unit where objects or pieces of furniture could be damaged by heat.

Respect distances and positions indicated in the installation section.

If the installer or user modifies the unit, they will be held responsible for any damage resulting from this modification, and the UL certification could be void.

This unit must not come into contact with a water source and must be protected from splashes (e.g. a wet mop). Do not use it if any part has been immersed.

When cutting or drilling into a wall, do not damage electrical wiring and other hidden utilities.

Because this unit is hot when in use, it may pose risks even in normal operation. Therefore, be careful and responsible when using it.

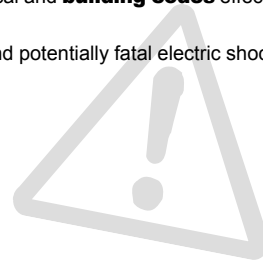

WARNING

Never block air vents. This obstruction could lead to overheating, which could result in a fire.

Do not insert or allow foreign objects to enter any air vent as this may cause electric shocks, a fire, or damages to the unit.

This unit has hot and arcing or sparking parts inside. It is not designed to be used or stored in wet areas or areas containing flammable liquids, combustible materials or corrosive, abrasive, chemical, explosive and flammable substances such as, but not limited to, gasoline, paint, chlorine, sawdust and cleaning products.

Some areas are dustier than others. Thus, it is the user's responsibility to evaluate if the unit must be cleaned based on the amount of dirt accumulated on and inside air vents. Accumulated dirt can lead to a component malfunction or give a yellowish colour to unit. Failure to install and maintain unit in accordance with these instructions poses a fire hazard.

Thermal protection activation indicates that the unit has been subjected to abnormal operating conditions. If the thermal protection remains activated or activates and deactivates repeatedly, it is recommended that a qualified electrician or a certified repair centre examine the unit in order to make sure it is not damaged. (Refer to the limited warranty)

If the unit is damaged or defective, cut off power supply at circuit breaker and call a certified repair centre. (Refer to the limited warranty)

Note: When a part of the product specification must be changed to improve operability or other functions, priority is given to the product specification itself. In such instances, the instruction manual may not entirely match all the functions of the actual product. Therefore, the actual product and packaging, as well as the name and illustration, may differ from the manual.

TECHNICAL DRAWINGS

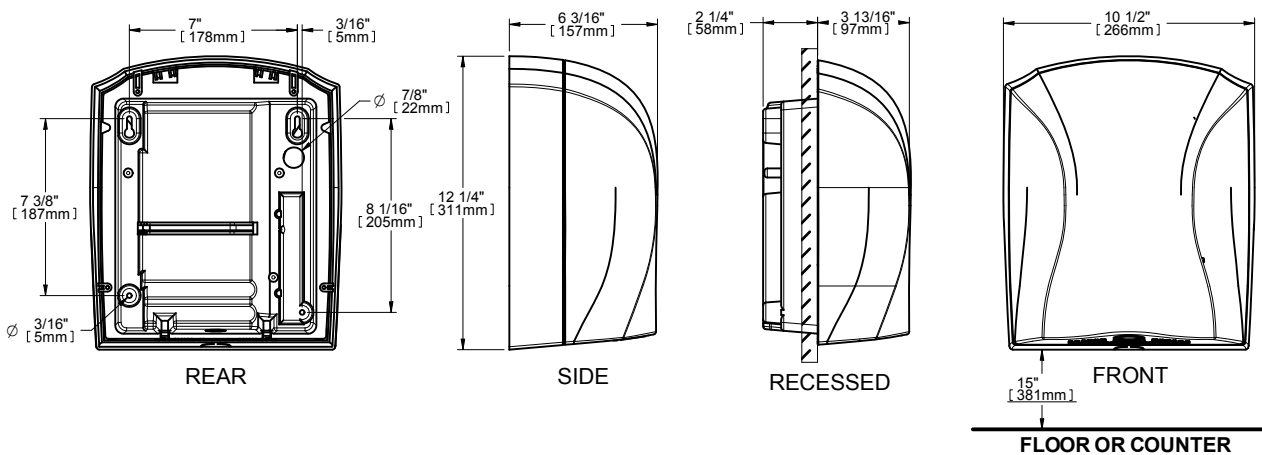

INSTALLATION

Suggested mounting height from bottom of dryer

MEN	45" (115 cm)
WOMEN	43" (110 cm)
TEENAGERS	41" (105 cm)
SMALL CHILDREN	35" (90 cm)
HANDICAPPED	37" (95 cm)
MINIMUM HEIGHT	15" (40 cm)

RECOMMENDED FASTENERS

Masonry walls: 1/2" expansion sleeve with 1/4" lag bolt

Hollow walls: 1/4" wing type through bolt

Wood walls: 1/4" lag screw with washer

ELECTRICITY:

TURN OFF THE POWER BEFORE CONNECTING THE UNIT

Check if the power supply corresponds to that indicated on the nameplate.

Connect the dryer to a bypass circuit according to electrical and building codes in your area.

Connect the power cable to the terminals of the hand dryers, as shown in the wiring diagram inside the cover of the dryer.

Do not forget to connect the ground wire to the ground cover on the terminal available at the motor base.

If the hand dryer is located in a shower or in other wet locations, it shall be protected by a ground fault circuit breaker.

Note: : When installing on a gypsum wall, ensure that at least two anchor bolts are set in a beam of wood or steel. Where possible, it is recommended to install a wooden beam behind the gypsum (see # 3). If the other 2 screws must be fixed in a hollow wall, use 1/4" wing type through bolts.

HOW TO REMOVE THE COVER OF THE HAND DRYER: (1-2-3)

Screw the two screws of the cover using the key supplied with each unit, slide the cover up, then tilt it backward to remove it.

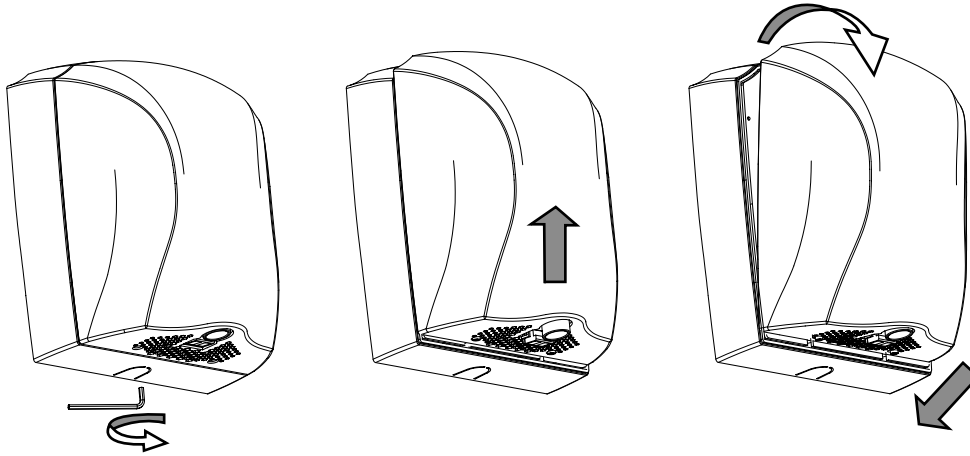

FIG. 1

FIG. 2

FIG. 3

HOW TO REPLACE THE COVER OF THE HAND-DRYER: EXECUTE STEPS IN REVERSE (3-2-1)

Fully insert the cover of the air outlet by tilting it, replace the cover on the housing and slide it down so that it clings to its support, then secure it by removing the 2 screws.

Check the serial number inside the hand-dryer before replacing the cover to ensure it matches the serial number at the bottom of the cover. **DO NOT SWITCH COVERS OF THE UNITS.**

RECESSED INSTALLATION

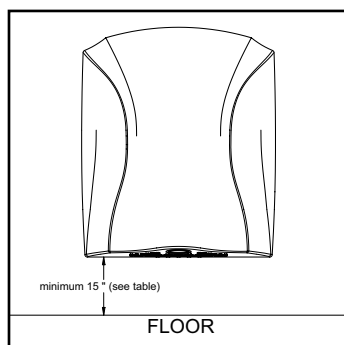

FIG. 1

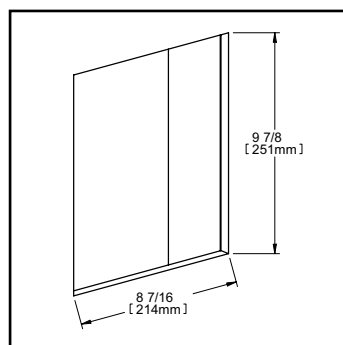

FIG. 2

Determine the location of the hand dryer and cut out a wall opening to the suggested dimensions.

Bring the power cable into the installation hole.

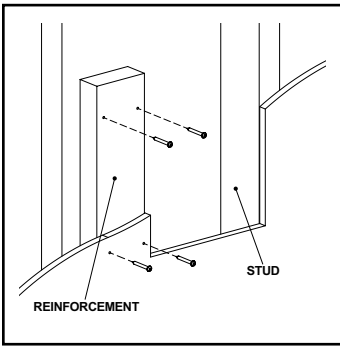

FIG. 3

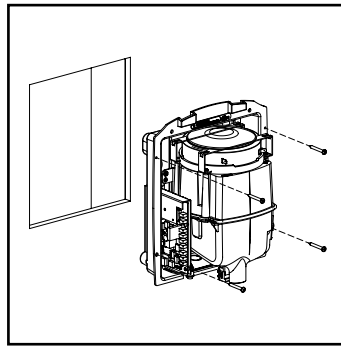

FIG. 4

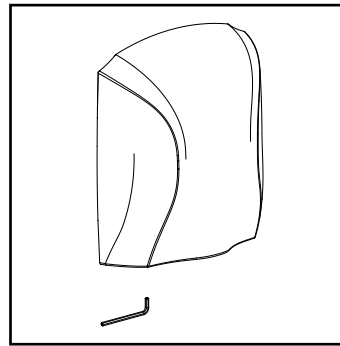

FIG. 5

After reinforcing the side of the installation hole (for drywall), remove the surface sleeve and insert the wall plate assembly in order to mark the mounting holes. Then secure the unit to the wall supports (joist and building block). Replace cover, do not forget to connect the ground wire.

SURFACE INSTALLATION

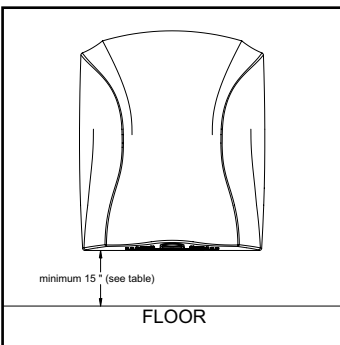

FIG. 1

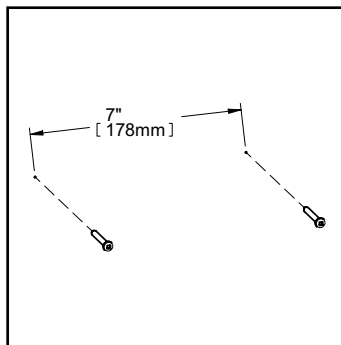

FIG. 2

Determine the location you want the hand dryer and screw the two top anchor screws as per the above dimensions and leave the screws out about 1/2 inch (13mm).

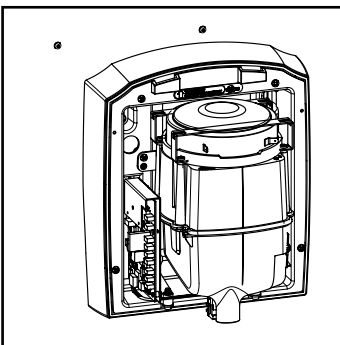

FIG. 3

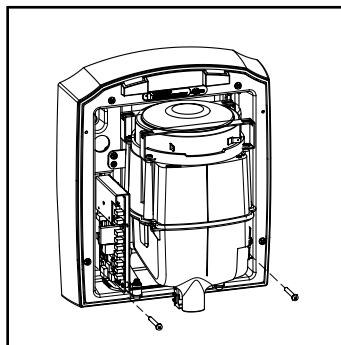

FIG. 4

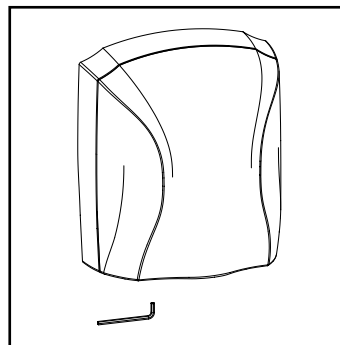

FIG. 5

Suspend the hand dryer on the two top anchor screws, locate the bottom holes and secure the unit to the wall with the two bottom anchor screws. Connect power cable to the hand dryer. Replace cover, do not forget to connect the ground wire.

CONTROLS

Your EL-NIÑO hand dryer is equipped with electronic controls to customize the unit to meet your needs.

FOUR OPERATIONAL MODES - DESCRIPTION AND SYMBOLS

- ULTIMATE** – High air speed and full heating power for quick drying
- COMFORT** – Reduced air speed and moderate heating power for a comfortable noise level and heat range
- ECONOMICAL** – High air speed without heat for quick drying with energy and cost savings
- HARMONY** – Reduced air speed without heat for energy savings and a moderate noise level

THREE SENSITIVITY DETECTIONS - DESCRIPTION AND SYMBOL

- Maximal detection – standard (4’’)
- Medium detection - decreased
- Minimal detection - minimum

FOR OPERATIONAL ADJUSTMENTS BY A QUALIFIED TECHNICIAN, FOLLOW THESE STEPS

1. Disconnect electricity to unit at breaker.
2. Remove cover by executing steps from Fig. 1 to 3 on the page 3.
3. Determine the operation mode and desired sensitivity by choosing the desired configuration of dip switches SW1 and SW2 as shown on the diagram here.
4. Replace cover and restore electricity.

NB : Never leave a powered unit (without its cover) unattended.

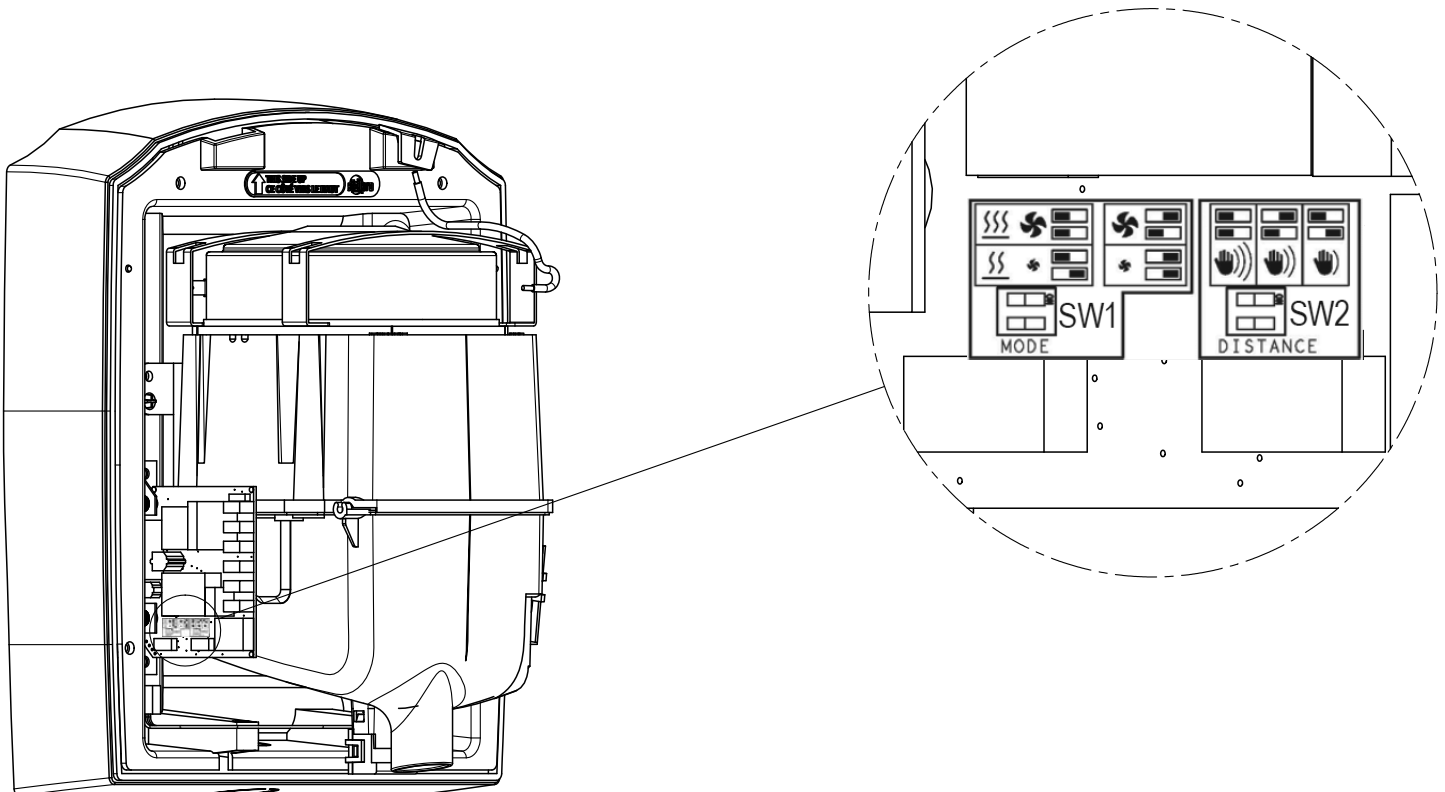

OPERATION

The hand dryer will start automatically once hands are placed 4 inches (10cm) below the opening of the air output. The unit will shut off once the hands are no longer below the opening.

MAXIMUM DURATION OF OPERATION

As long as the sensor detects the presence of the hands, the unit will function continuously for 60 seconds. After this delay, the user must withdraw his hands and put them back under in order for the unit to start up again

The hand dryer will stop 1 second after no hand movement is detected

MAINTENANCE

N.B. In order for the warranty to be valid, the unit must be cleaned regularly.

SWITCH OFF THE MAIN BREAKER IN THE ELECTRICAL PANEL OR REMOVE THE FUSE BEFORE CLEANING THE UNIT.

OUTSIDE

Gently wash cover (including air Inlet holes) using a soft cloth or sponge and a mild soap or detergent with luke warm water to loosen dirt and grime.

INSIDE

CLEANING SHOULD BE PERFORMED BY QUALIFIED SERVICE PERSONNEL

In normal use, dryer will require cleaning once a year. Heavier usage requires more frequent cleaning. Lint on the air inlet or other internal parts of dryer will reduce efficiency and shorten the life of the working parts. To clean, remove cover by screwing the tamper-proof bolts from cover with the special wrench provided with each dryer. Use a small, soft brush to gently clean all parts.

TROUBLESHOOTING

PROBLEM	DEFECTIVE PART OR PART TO CHECK
The hand dryer does not turn on	<ul style="list-style-type: none">• Verify that the dryer is receiving power by checking electrical service, circuit breaker or fuse• Obstructed or defective infrared sensor• Check for loose wires on dryer control and for foreign material on dryer sensor next to air outlet• Check motor• Defective control board
The hand dryer runs continuously	<ul style="list-style-type: none">• Obstructed or defective infrared sensor• Defective control board
The hand dryer does not turn on, or turns on by itself	<ul style="list-style-type: none">• Obstructed or defective infrared sensor• Check for foreign material on optical sensor next to air outlet• Check for loose wires on dryer control
The hand dryer blows only cool air	<ul style="list-style-type: none">• Check if Economical or Harmony mode is selected• Check for loose connections to heating element• Replace heating element

N.B. If you do not solve the problem after checking these points, cut off the power supply at the main electrical panel and contact our customer service (see the “Limited warranty” section to obtain the phone numbers).

REPLACEMENT COMPONENT LIST

REF. #	PART #	DESCRIPTION
1	ELN-002W	COVER (MOUNTING BRACKETS INCLUDED) WHITE
	ELN-002BC	COVER (MOUNTING BRACKETS INCLUDED) BRUSHED CHROME
2	ELN-004W	SURFACE ADAPTER WHITE
	ELN-004BC	SURFACE ADAPTER BRUSHED CHROME
3	MO-79	120V 50/60HZ 130CFM
	MO-80	208V 50/60HZ 130CFM
	MO-81	240V 50/60HZ 130CFM
4	ELF-ELN0901	HEATING ELEMENT ASSEMBLY 120 V/900 W
5	CIR-033	ELECTRONIC CIRCUIT BOARD ELNINO HAND DRYER NEW GENERATION
6	CIR-008	INFRARED SENSOR
7	ELN-001	5VA PLASTIC ENCLOSURE
8	ELN-013	TAMPER-PROOF WRENCH
9	PROT-111	THERMAL PROTECTION L140-20°F
10	ELN-007	RUBBER INSULATOR

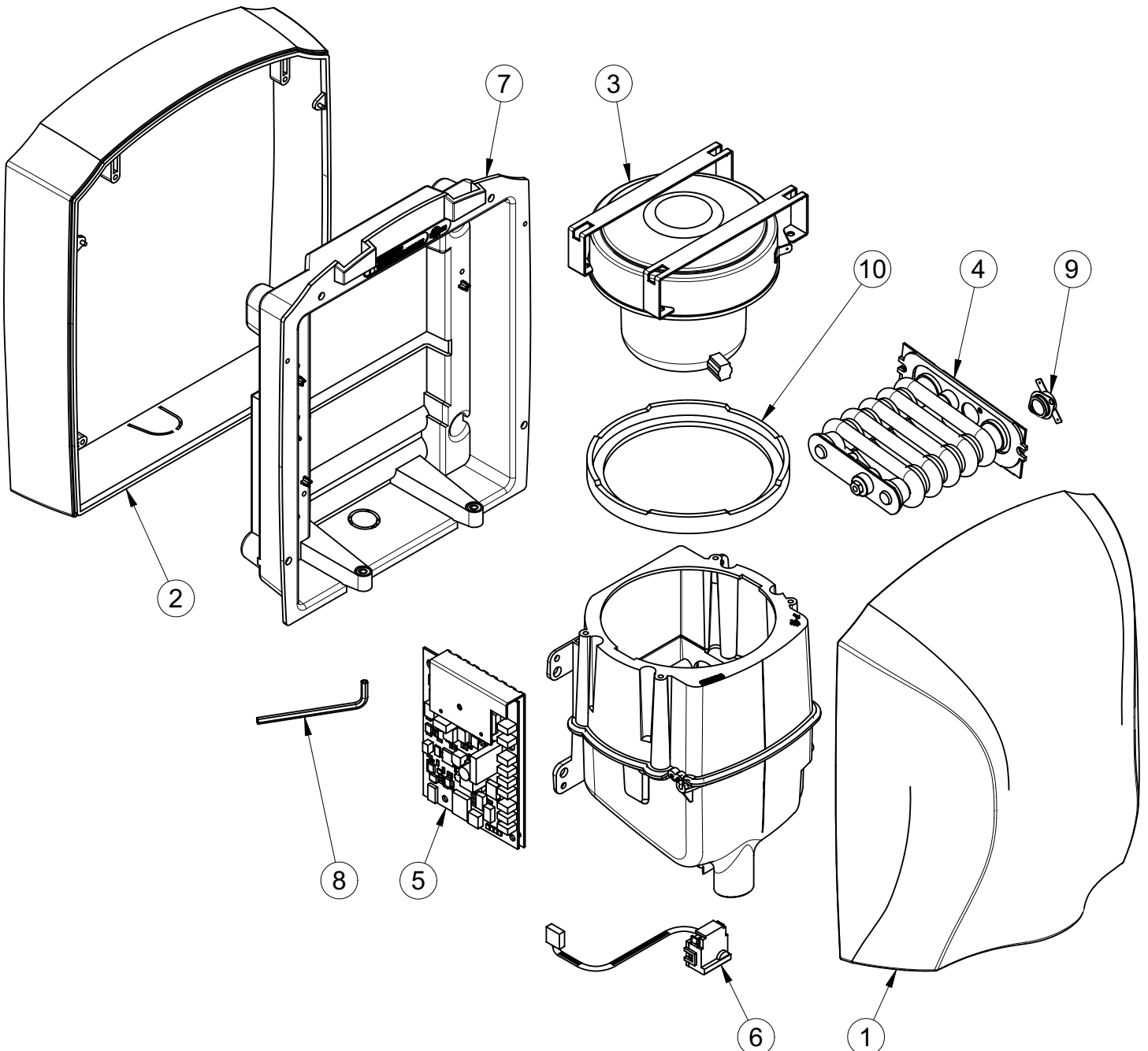

LIMITED WARRANTY

This limited warranty is offered by Stelpro Design Inc. ("Stelpro") and applies to the following product made by Stelpro: ELN models. **Please read this limited warranty carefully. Subject to the terms of this warranty, Stelpro warrants its products and their components against defects in workmanship and/or materials for the following period from the date of purchase: 5 years (3 years on electronic components).** This warranty applies only to the original purchaser; it is non-transferable and cannot be extended.

CLAIM PROCEDURE

If at any time during the warranty period the unit becomes defective, you must cut off the power supply at the main electrical panel and contact 1) your installer or distributor, 2) your service center or 3) Stelpro's customer service department. In all cases, you must have a **copy of the invoice** and provide **the information written on the product nameplate**. Stelpro reserves the right to examine or to ask one of its representatives to examine the product itself or any part of it before honoring the warranty. Stelpro reserves the right to replace the entire unit, refund its purchase price or repair a defective part. Please note that repairs made within the warranty period must be authorized in advance in writing by Stelpro and carried out by persons authorized by Stelpro.

Before returning a product to Stelpro, you must have a Stelpro authorization number (RMA). To obtain it, call the customer service department at: **1-800-363-3414** (electricians and distributors - French), **1-800-343-1022** (electricians and distributors - English), or **1-866-766-6020** (consumers). The authorization number must be clearly written on the parcel or it will be refused.

CONDITIONS, EXCLUSIONS AND DISCLAIMER OF LIABILITY

This warranty is exclusive and in lieu of all other representations and warranties (except of title), expressed or implied, and Stelpro expressly disclaims and excludes any implied warranty of merchantability or implied warranty of fitness for a particular purpose.

Stelpro's liability with respect to products is limited as provided above. Stelpro shall not be subject to any other obligations or liabilities whatsoever, whether based on contract, tort or other theories of law, with respect to goods or services furnished by it, or any undertakings, acts or omissions relating thereto. Without limiting the generality of the foregoing, Stelpro expressly disclaims any liability for property or personal injury damages, penalties, special or punitive damages, damages for lost profits, loss of use of equipment, cost of capital, cost of substitute products, facilities or services, shutdowns, slowdowns, or for other types of economic loss or for claims of a dealer's customers or any third party for such damages.

Stelpro specifically disclaims all consequential, incidental and contingent damages whatsoever.

This warranty does not cover any damages or failures resulting from: 1) a faulty installation or improper storage; 2) an abusive or abnormal use, lack of maintenance, improper maintenance (other than that prescribed by Stelpro) or a use other than that for which the unit was designed; 3) a natural disaster or an event out of Stelpro's control, including, but not limited to, hurricanes, tornadoes, earthquakes, terrorist attacks, wars, overvoltage, flooding, water damages, etc. This warranty does not cover any accidental or intentional losses or damages, nor does it cover damages caused by negligence of the user or owner of the product. Moreover, it does not cover the cost of disconnection, transport, and installation.

The warranty is limited to the repair or the replacement of the unit or the refund of its purchase price, **at the discretion of Stelpro**. Any parts replaced or repaired within the warranty period with the written authorization of Stelpro will be warranted for the remainder of the original warranty period. This warranty will be considered null and void and Stelpro will have the right to refuse any claims if **products have been altered** without the written authorization of Stelpro and if the nameplate numbers have been removed or modified. This warranty does not cover scratches, dents, corrosion or discoloration caused by excessive heat, chemical cleaning products and abrasive agents. It does not cover any damage that occurred during the shipping.

Some states and provinces do not allow the exclusion or limitation of incidental or consequential damages and some of them do not allow limitations on how long an implied warranty lasts, so these exclusions or limitations may not apply to you. This warranty gives you specific legal rights and you may have other rights which vary from state to state or from province to province.