

THIS COPY IS PROVIDED ON A RESTRICTED BASIS AND IS NOT TO BE USED IN ANY WAY DETRIMENTAL TO THE INTERESTS OF PANDUIT CORP.

| PANDUIT PART # | WIRE RANGE | | REEL QTY. | COLOR (DIN) | MAX. WIRE INSUL. DIA. | WIRE CLASS | DIMENSIONS in. [mm] | | | | CP-881 INSERTS | SCA-71202 2002 (CA10) DIE SET | UNI-M DIE SET | ** UNI-M (JM9D) INSERTER KIT/ *** UNI-M (JVD) FUNNEL KIT |
|----------------|------------|--------------------|-----------|-------------|-----------------------|------------|---------------------|-----------|-----------|-----------|----------------|-------------------------------|-----------------|---|
| | AWG | [mm ²] | | | | | L | P | OD (REF.) | ID | | | | |
| * FSD73-8-K | 24 | [0,25] | 1000 | YELLOW | .07 [1,8] | B, K, M | .57 [14,5] | .31 [8,0] | .05 [1,3] | .03 [0,8] | ++CP-881-KIT4 | -- | ALL ONE DIE SET | -- |
| * FSD74-8-K | 22 | [0,34] | 1000 | TURQUOISE | .07 [1,8] | B, K, M | .57 [14,5] | .31 [8,0] | .05 [1,3] | .03 [0,8] | CP-881-KIT4 | | | |
| + FSD75-8-K | 20 | [0,50] | 1000 | WHITE | .09 [2,4] | B, K, M | .57 [14,5] | .31 [8,0] | .06 [1,4] | .04 [1,1] | WHITE INSERTS | SCA-712002005WE (CD10-1) | ALL ONE DIE SET | APM-K008701/ APM-K017697 |
| FSD76-8-K | 18 | [0,75] | 1000 | GRAY | .10 [2,6] | B, K, M | .57 [14,5] | .31 [8,0] | .06 [1,6] | .05 [1,3] | GRAY INSERTS | | | APM-K008175/ APM-K015949 |
| FSD77-8-K | - | [1,0] | 1000 | RED | .11 [2,8] | B, K, M | .57 [14,5] | .31 [8,0] | .07 [1,8] | .06 [1,5] | RED INSERTS | SCA-712002006WE (CD10-2) | ALL ONE DIE SET | APM-K006667/ APM-K017698 |
| FSD78-8-K | 16 | [1,5] | 1000 | BLACK | .13 [3,2] | B, K, M | .57 [14,5] | .31 [8,0] | .08 [2,1] | .07 [1,8] | BLACK INSERTS | | | |
| FSD80-8-DK | 14 | [2,5] | 500 | BLUE | .15 [3,9] | B, K, M | .57 [14,5] | .31 [8,0] | .10 [2,6] | .09 [2,3] | BLUE INSERTS | SCA-71200 2007WE (CD10-3) | ALL ONE DIE SET | APM-K008585/ APM-K017699 |

* NOT UL LISTED, UL486F SCOPE IS 20 - 1/0 AWG. TURQUOISE IS DIN COLOR FOR 22 AWG [0,34]. FOR CP-881 TOOL, FSD74-8-K ONLY WORK FOR 22 AWG WIRE.
 ** INSERTER KIT OPTIONAL. (MRSP1516JM9D)
 *** VERTICAL FUNNEL KIT OPTIONAL. (APM-MRSP1516JVD/APM-MRSP1516PAN)
 + UL LISTED WITH 20 AWG ONLY, WHITE IS DIN COLOR FOR 20 AWG [0,5]
 ++ ONLY COMPATIBLE WITH CERTAIN WIRE TYPES AND DIAMETERS.
 CONTACT SALES OR CUSTOMER SERVICE FOR A DEMONSTRATION UNIT.

NOTES:

- USED FOR:
 - UL LISTED WITH STRANDED COPPER WIRE 20 - 1/0 AWG ONLY
 - 221°F (105°C) MAX. OPERATING TEMPERATURE
- INSTALLATION TOOLS PANDUIT APPROVED:
 - CA10 APPLICATOR WITH CP-871 OR EQUIVALENT PRESS
 - CP-881 STRIP AND CRIMP UNIT
 - SCA-712022002 (CA10) APPLICATOR WITH UC200 OR EQUIVALENT PRESS
 - UNI-M APPLICATOR (MRSP1516JM9D) WITH UC200 OR EQUIVALENT PRESS
 - UNI-M APPLICATOR (MRSP1516JVD) WITH UC200 OR EQUIVALENT PRESS
- WIRE STRIP LENGTH: 13/32 ^{+1/32}₋₀ [10 ^{+0,8}₋₀]
- MATERIAL:
 - STAMPING: COPPER, TIN PLATED
 - HOUSING: POLYPROPYLENE, COLOR CODED
 - COLOR CODE CONFORMS TO DIN STANDARD
- SEE www.panduit.com FOR PACKAGE QUANTITIES
- DIMENSIONS IN BRACKETS ARE IN MILLIMETERS
- PARTS CONFORM TO DIN 46228 PART 4

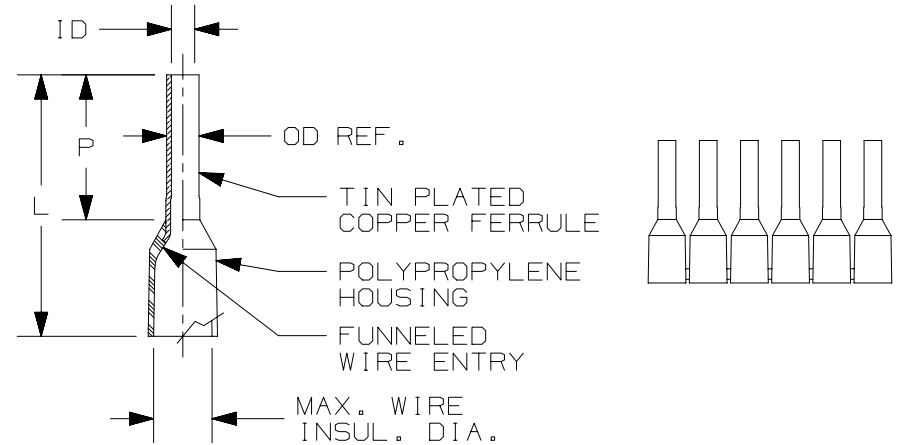

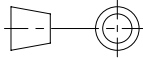
| | | |
|--------------------|--|--------------------------|
| PART NUMBER | SEE TABLE | |
| TITLE | FERRULES WITH SLEEVES ON MINI REEL (DIN) | |
| | CUSTOMER DRAWING | |
| ITEM REVISION NAME | N41755BA/14 | |
| DATASET FILE NAME | N41755BA_DC/14A | |
| |  THIRD ANGLE PROJECTION | |
| MATERIAL | SEE NOTES | DRAWING NUMBER A41755 |
| DRAWN BY | DATE | CHK |
| SRB | 01-11 | - |
| SCALE | N.T.S | |
| SHEET 1 OF 1 | | SIZE A |

| 14A | 08-21-23 | DPOI | JBN | MRWA ASY | ADDED UL ENHANCED MARK - US, CA & UPDATE BORDER. | 128785/01 |
|-----|----------|------|-----|----------|--|-----------|
| REV | DATE | BY | CHK | APR | DESCRIPTION | ECN |

A-SIZE CUSTOMER

B

A