

Application

Output Contact Arrangements Terminal Pin Assignments

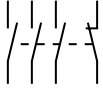

14	⊗	⊗	S12	A1	⊗	⊗	13
24	⊗	⊗	S13	S11	⊗	⊗	23
34	⊗	⊗	S10	S14	⊗	⊗	33
42	⊗	⊗	A2	S21	⊗	⊗	41

Terminal Connections

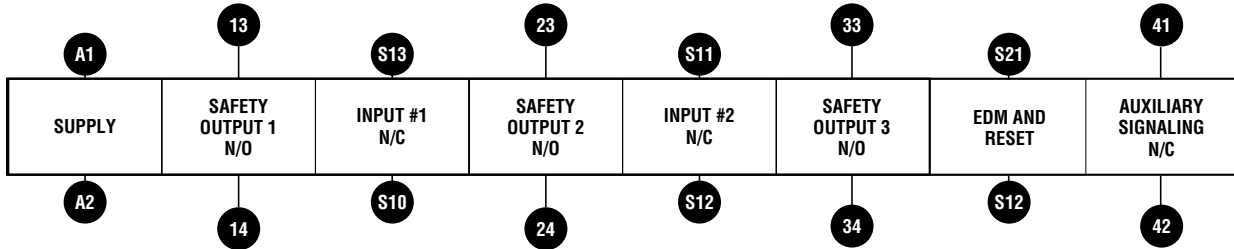

24VAC/DC, 110VAC

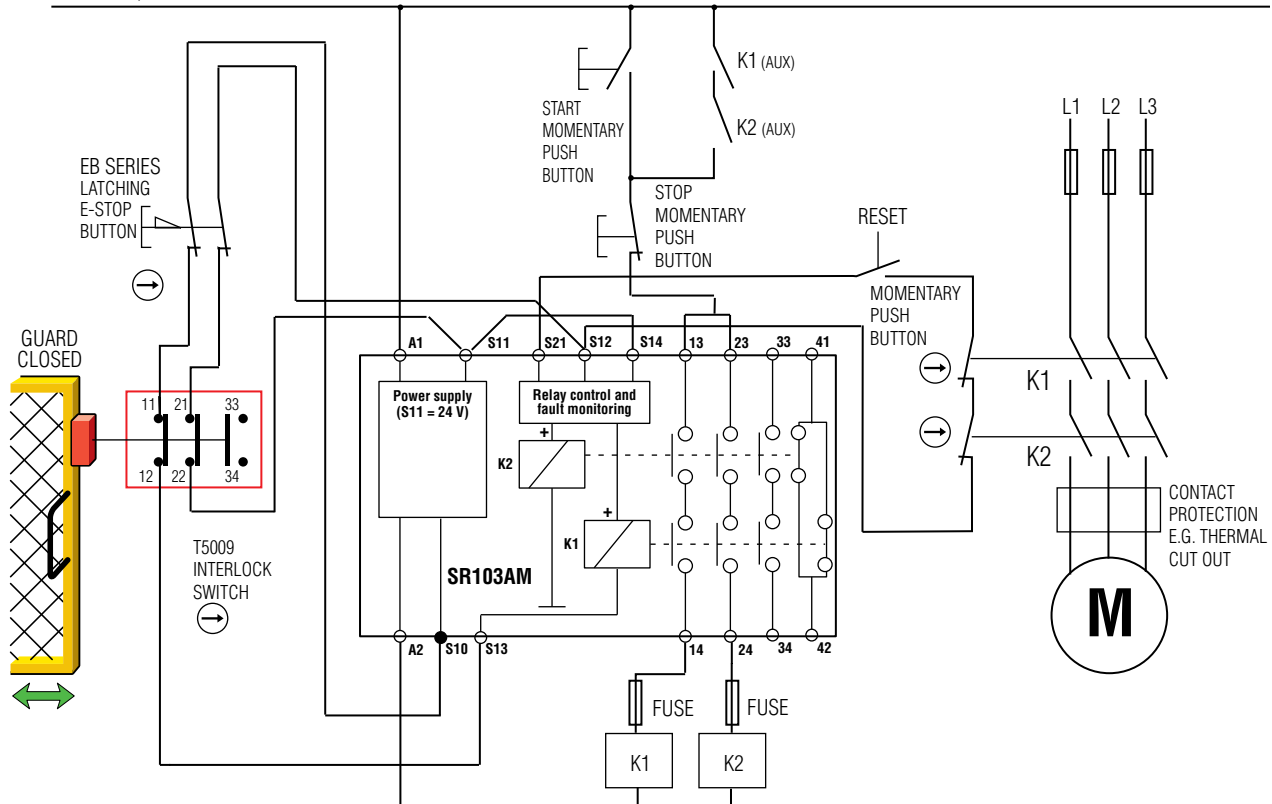

For a full explanation of the circuit operating principle and fault detection, see "Common Circuit Examples" in The Expert Area Section of this catalog on page A31.

Select models are available for Rapid Delivery.

Visit this product on www.sti.com for details.

Application (continued)

MS4600 Connected to SR103AM

(MPCE monitoring disabled)

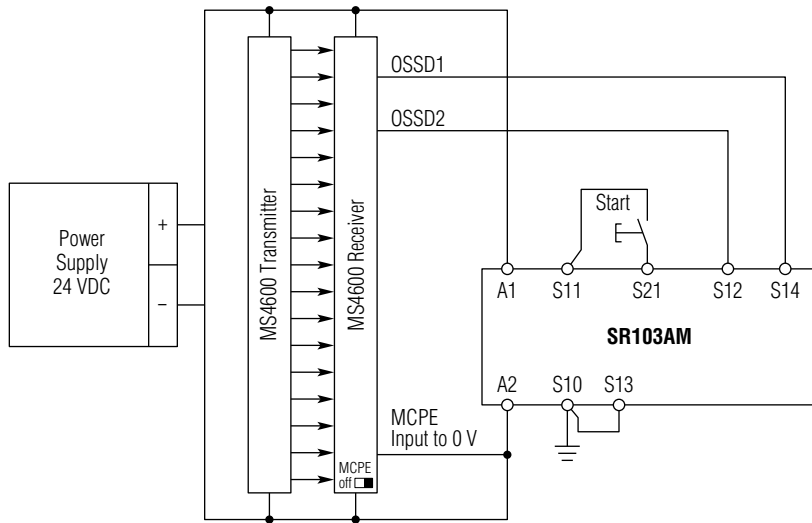

MPCE Monitoring “Disabled”

The start switch shown connected between S11 and S21 provides a monitored manual start function. Switch must be closed and then opened to activate a start. For auto-start, connect a wire between S21 and S12 and no connection between S11 and S21.

If the MPCE function is not being used on the MS4600 light curtain, the function must be “disabled”, and the MPCE input wire must be connected to 0 V (GND).

MPCE Monitoring “Enabled”

When using an SR103AM with an MS4600 light curtain, MPCE monitoring may be performed through the safety monitoring relay using terminals S12, S21. This method of MPCE monitoring only allows for Auto Restart/Manual Restart Mode of the safety monitoring relay. If Monitored Manual Restart Mode with MPCE Monitoring is desired, the MPCE Monitoring must be enabled and performed through the MS4600 light curtain. Place wire jumper between terminals S12, S21 of the safety monitoring relay. Configure the MS4600 for Start/Restart Interlock Mode. The Monitored Manual Reset is now controlled through the MS4600 light curtain. (See MS4600 Manual for configuration and wiring details of MS4600 light curtain.)

J

Select models are available for Rapid Delivery.

Visit this product on www.sti.com for details.

Block Diagram

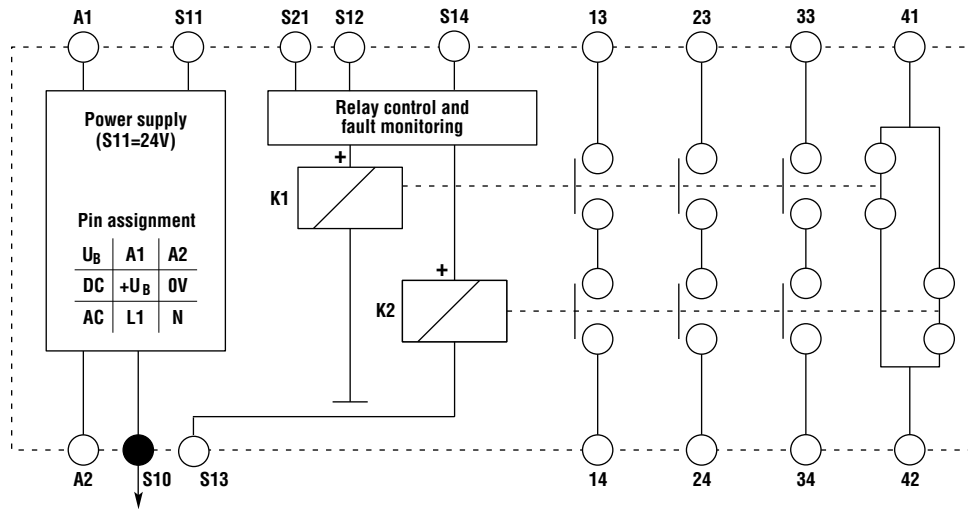

Dimensions

(mm/in.)

SR103AM

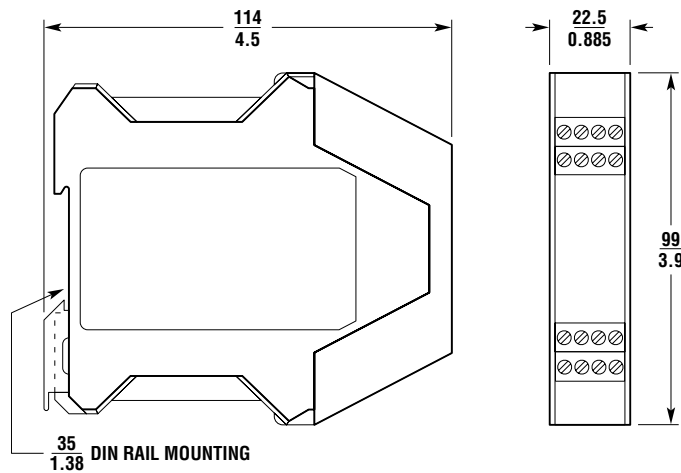

Ordering

Model	Supply	Inputs	Outputs	Auxiliary	Part No.
SR103AM01	24 VAC/DC	2 N/C	3 N/O	1 N/C	44510-1031
SR103AM02	115 VAC	2 N/C	3 N/O	1 N/C	44510-1032

Select models are available for Rapid Delivery.

Visit this product on www.sti.com for details.