

Panel Mount Surge Protective Devices (SPDs)

51120 Series Type 1 and Type 2

UL 1449
3rd Edition
Compliant



Leviton's 51120 panel mount surge arresters are designed for use in homes and apartment buildings at the service entrance, electrical utility meter, or other branch panel locations. They are also ideal for use in pumping stations,

radio towers and light commercial buildings where protection from high-energy, high-voltage transients is desired. These surge arresters are available for single-phase and three-phase applications.

Features and Benefits

- Tested to ANSI/IEEE C62.41 standards
- Single high-energy solid-state semiconductor surge suppression circuitry per phase
- Real-time diagnostic visual indicator shows power and suppression status for each protected phase
- Each phase provided with independent thermal fuse protection
- Feature a low VPR to ensure protection of sensitive electronic devices including LCD TVs, PDAs and computers
- Standard J-Box enclosure with pre-punched standard knock-outs can be easily surface mounted in typical frame construction
- Internal DIN rail module provides for easy replacement (on Type 1 outdoor unit only)
- All versions are compatible with Leviton Decora Home Controls
- Limited Lifetime Product Warranty
- Connected equipment coverage up to \$25,000 for the 51120-1 and 51120-3R*

* As part of the True Whole House Surge Protection Warranty



Specifications

Material Specifications				
Outer Enclosure	Metal			
Module Enclosure	Polycarbonate			
Contacts	Copper			
Mechanical Specifications				
Connection Type	Hardwired Parallel Connection: up to #12AWG			
Diagnostics	Protection status LEDs			
Electrical Specifications				
Cat. No.	51120-1	51120-3	51120-3R	
Voltage	120/240V AC, single-phase	120/208V AC, 3-phase WYE	120/240V AC, single-phase	
Surge Technology	MOV	MOV	TPMOV	
Frequency	50/60Hz	50/60Hz	50/60Hz	
Performance Data				
Cat. No.	51120-1	51120-3	51120-3R	
Maximum Continuous Operating Voltage (MCOV)	L-N	150V	150V	150V
	L-L	300V	300V	300V
Voltage Protection Rating (VPR) (Clamping)	L-N	800V	800V	500V
	L-L	1200V	1200V	800V
Nominal Discharge Rating (In)	3kA	3kA	20kA	
Maximum Surge Current Per Mode	50kA	50kA	50kA	
Environmental Specifications				
Cat. No.	51120-1	51120-3	51120-3R	
Enclosure type	NEMA 1	NEMA 1	NEMA 3R	
Flammability	Rated V-2 per UL 94*	Rated V-2 per UL 94*	Rated V-2 per UL 94*	
Operating Temperature	-10°C to 60°C	-10°C to 60°C	-10°C to 60°C	
Storage Temperature	-20°C to 85°C	-20°C to 85°C	-20°C to 85°C	
*Flammability rating applies to module only				
Standards & Certifications				
Cat. No.	51120-1	51120-3	51120-3R	
UL 1449 3rd Ed	UL Listed	UL Listed	ETL Certified	
National Electric Code (NEC)	—	—	285	
ANSI/IEEE Category A, B & C	C-62.41 & C-62.45	C-62.41 & C-62.45	C-62.11, C-62.41 & C-62.45	
Warranty	Limited Lifetime			
Connected Equipment Coverage for 51120-1 and 51120-3R	Up to \$25,000*			

* As part of the True Whole House Surge Protection Warranty

Leviton Manufacturing Co., Inc.

201 N Service Rd, Melville, NY 11747
 Telephone: 1-800-323-8920 • Fax: 1-800-832-9538
 Tech Line (8:30AM-7:00PM E.S.T. Monday-Friday): 1-800-824-3005

Leviton Manufacturing of Canada, Ltd.

165 Hymus Blvd, Pointe-Claire, QC H9R 1E9
 Telephone: 1-800-469-7890 • Fax: 1-800-563-1853

Leviton S. de R.L. de C.V.

Lago Tana 43, Col. Huichapan, Miguel Hidalgo, CP 11290 México DF
 Telephone: (+52) 55-5082-1040 • Fax: (+52) 55-5386-1797 • www.leviton.com.mx

Visit our Website at: www.leviton.com/industrial email: industrial@leviton.com

© 2011 Leviton Manufacturing Co., Inc. All rights reserved.

Dimensions

51120-1 & 51120-3

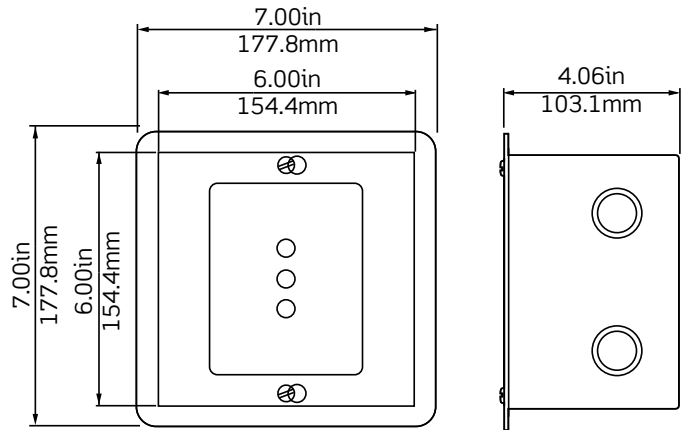

51120-3R

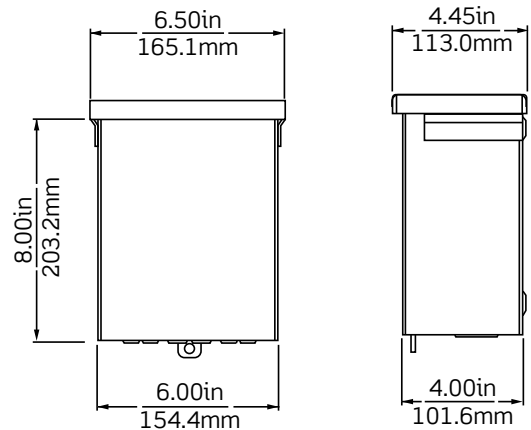

Ordering Information

Description	Cat. No.
Type 2 Indoor, Panel Mount Surge Protective Device 120/240V AC, single-phase	51120-1
Type 2 Indoor, Panel Mount Surge Protective Device 120/208V AC, 3-phase WYE	51120-3
Type 1 Outdoor, Panel Mount Surge Protective Device 120/240V AC, single-phase	51120-3R

