

LED Landscape Lighting — Inground Lights

MODEL OD-UGB201U



HIGHLIGHTS

- LED inground light with solid brass housing
- Can be embedded in hardscaping materials or concrete
- Designed to hold up against the hardscaping materials / concrete
- Installed in sidewalks, large mature trees, walls & flagpoles to illuminate the ways

SPECIFICATIONS

Model	OD-UGB201U
Voltage	12V AC
Housing	Solid brass
Lamp Base	GU5.3 Bi-pin base
Lamp	12V MR16 bulb (not included)
Lens	Convex glass
Wiring	3'18/2 UL wire, SVT-2W leads
Operating Temp.	-25°C ~ +40°C
Warranty	5 years

DIMENSIONS

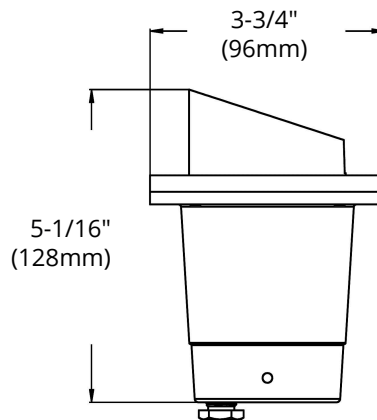

Reference	QTY.	Remarks	Project:
			Location:
			Architect:
			Engineer:
			Contractor:
			Submitted by:
			Date:

ORTECH reserves the right to modify at any time, without notice, any or all of our product's features, designs, components and specifications to meet market changes.