

M-13892

4

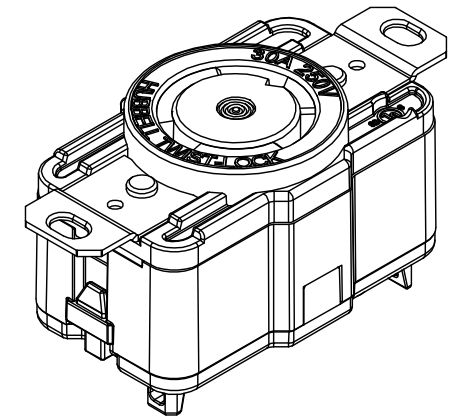
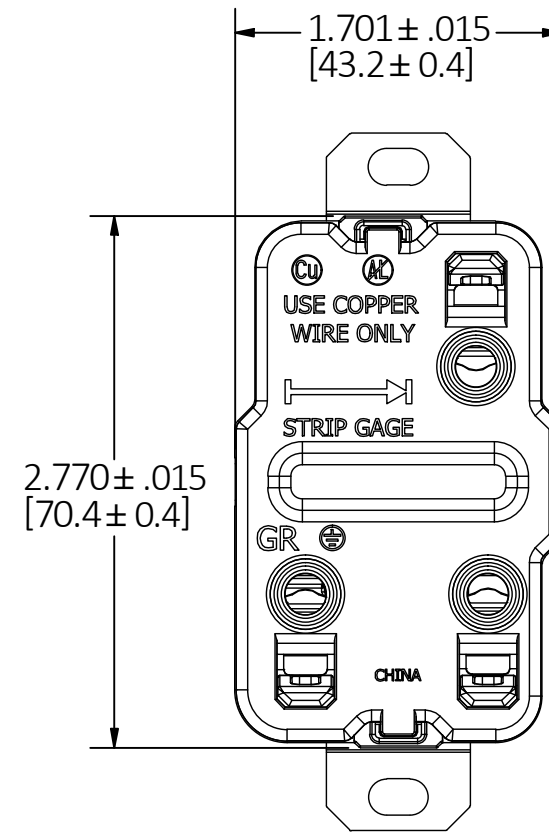
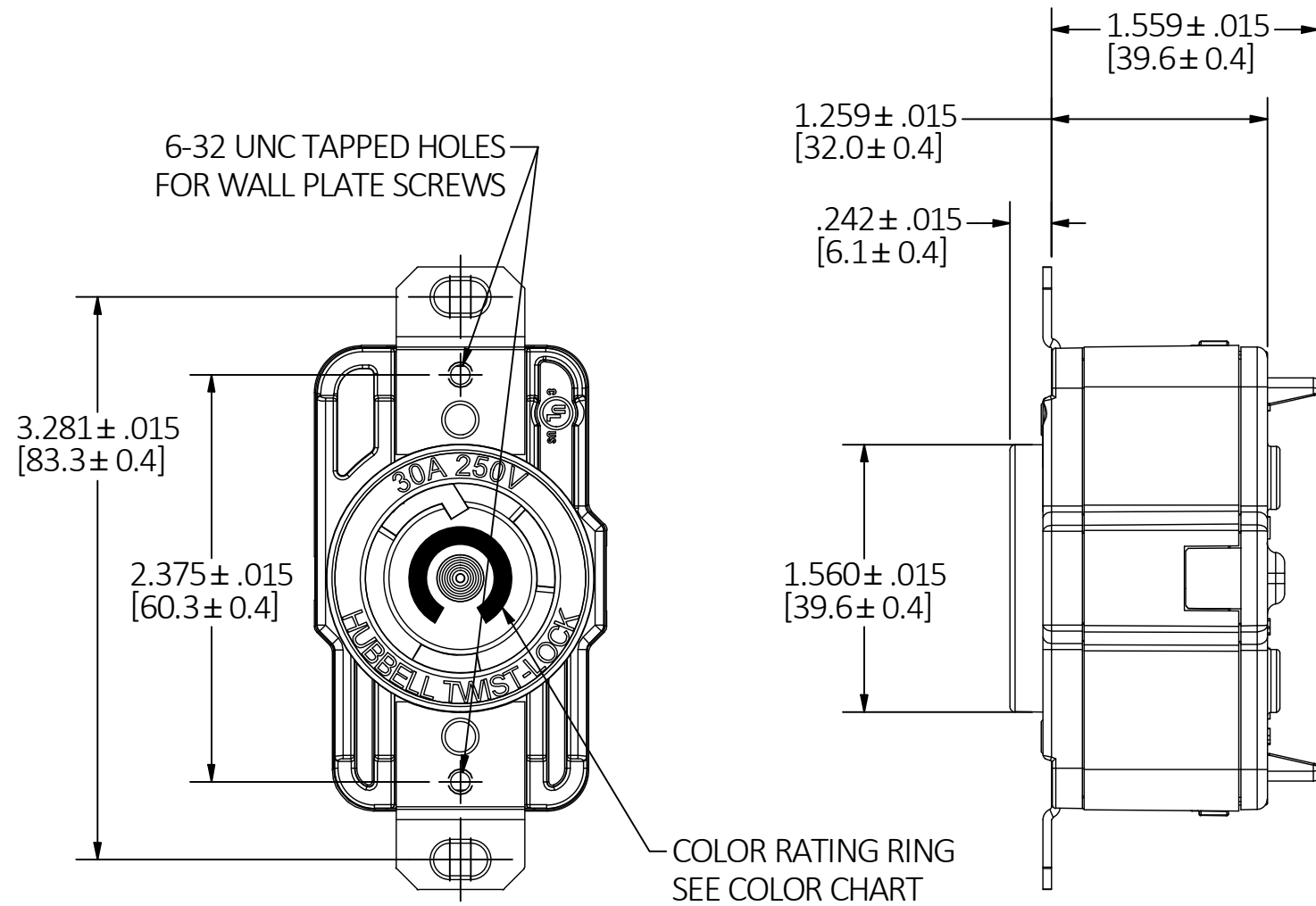

LIST OF PARTS		
DESCRIPTION	MATERIAL	FINISH
COVER	THERMOPLASTIC	
MID HOUSING	THERMOPLASTIC	
BASE	THERMOPLASTIC	
CONTACTS	BRASS	
SPRING	STEEL	
PLUNGER	THERMOPLASTIC	
GR. SHUNT	BRASS	
MOUNTING PLATE	BRASS	
RIVET	BRASS	

CAT NO.	NEMA NO.	RATING	POLE/WIRE	CONFIGURATION	RATING RING COLOR
HBL2610ST	L5-30	30A 125V	2P/3W GROUNDING		YELLOW
HBL2620ST	L6-30	30A 250V	2P/3W GROUNDING		BLUE

NOTES:

- DIMENSIONS ARE IN INCHES [mm].
- WIRING TERMINAL ACCOMMODATION:
  - SOLID WIRE: 14 AWG - 10 AWG COPPER WIRE ONLY
  - STRANDED WIRE (INCLUDING COMPACT STRANDED): 14 AWG - 8 AWG COPPER WIRE ONLY
- CONDUCTOR STRIP LENGTH: 0.600" (15.24mm)

REV	DESCRIPTION	APP	DATE
4	CONDUCTOR RANGE UPDATED IN NOTES PER DCN 220315017977 AM	RGP	03/14/22
3	CORRECTED RATING, V WAS VAC PER DCN 200213062132	WHD	02/12/20

THE DESIGN AND DIMENSIONS OF THE PRODUCT SHOWN ON THIS DRAWING ARE SUBJECT TO CHANGE WITHOUT NOTICE. DIMENSIONS ARE IN INCHES [mm].

TITLE  
CUST. DWG, 30A 3 WIRE SPRING TERMINATION RECEPTACLE



WIRING DEVICE-KELLEMS  
HUBBELL INCORPORATED  
SHELTON, CT

TOLERANCES UNLESS OTHERWISE SPECIFIED  
.XX = ± .01  
.XXX = ± .005  
ANGLE TOL. ±2°

DR. BY EB  
CHK. BY TLS

SCALE 1:1  
DATE 10/26/18