

COMPONENT LIST

ITEM NO.	DESCRIPTION	MAT'L	COMPONENT NO.	QTY.
1	GRIP, CORD	SST/AL	044-16-004	1
2	NUT	ALUM	311-48-027	1
3	BUSHING	NEOP	315-18-110	1
4	BODY	ALUM	311-48-008	1
5	CARTON	PAPER	309-20-027	1/5
6	INSTRUCTION	PAPER	309-20-059	1/5
7	LABEL	PAPER	309-75-002	2/5

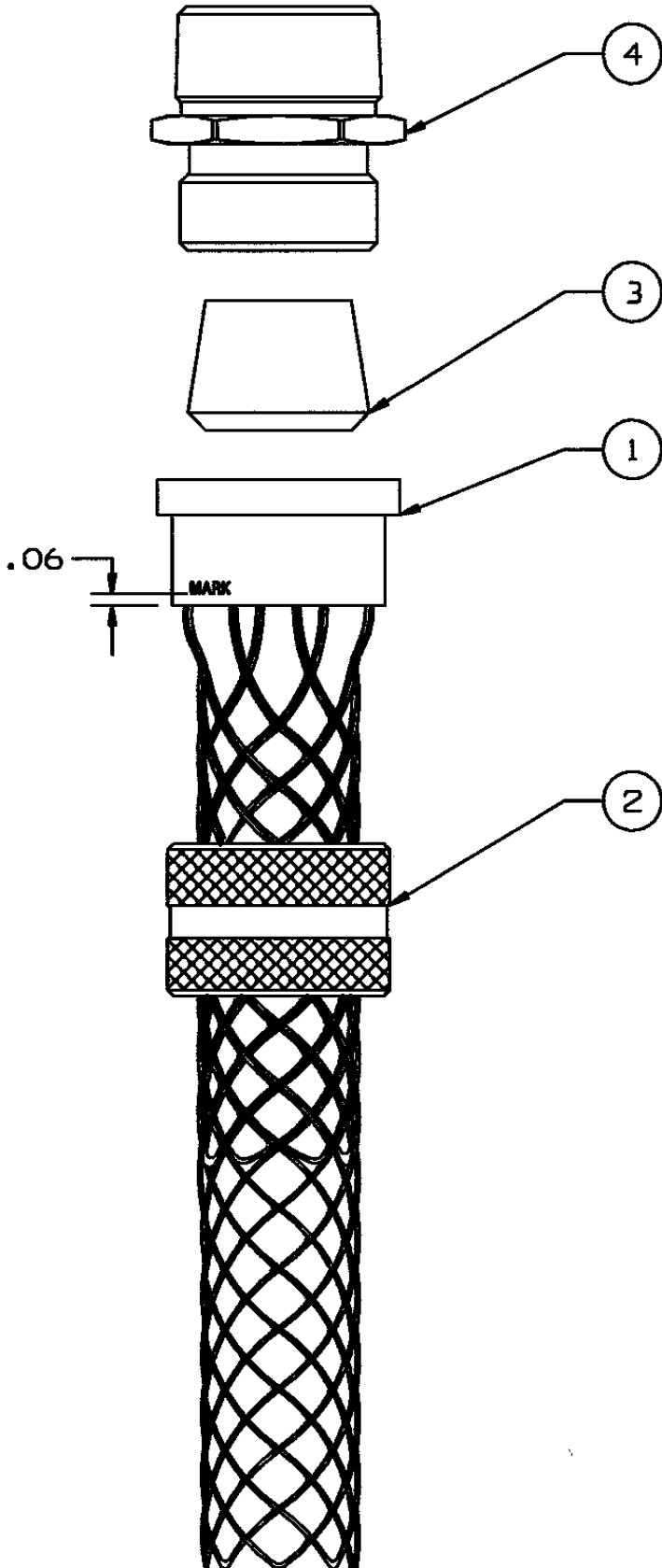

SUPERSEDES DRAWING
DATED 3-17-77

IN ACCEPTING OUR DRAWINGS OR BLUEPRINTS FOR QUOTATION OR OTHER PURPOSES, YOU AGREE NOT TO DISCLOSE TO OTHERS THE IDEAS, INFORMATION, OR DESIGNS THEREIN SHOWN, AND THAT YOU WILL MAKE NO USE OF OUR DRAWINGS OR BLUEPRINTS OR OF THE IDEAS, INFORMATION, OR DESIGNS THEREIN SHOWN WITHOUT OUR PERMISSION.

TITLE DELUXE CORD GRIP
STRAIGHT MALE; 3/4"NPT,
FORM 2 DIA. RA. .187-.250
CG 604

TOLERANCES UNLESS OTHERWISE SPECIFIED
.X = ±.5
.XX = ±.05
.XXX = ±.015
ANGLE TOL. ± 2°

HUBBELL INCORPORATED
KELLEMS DIVISION
STONINGTON, CT

PROJECT NO.

DR. BY KB	APP. BY
TR. BY JMN	SCALE N/A
CHK. BY	DATE 3/23/95

DR. NO.

074-01-011

REV.

L