

M-99282

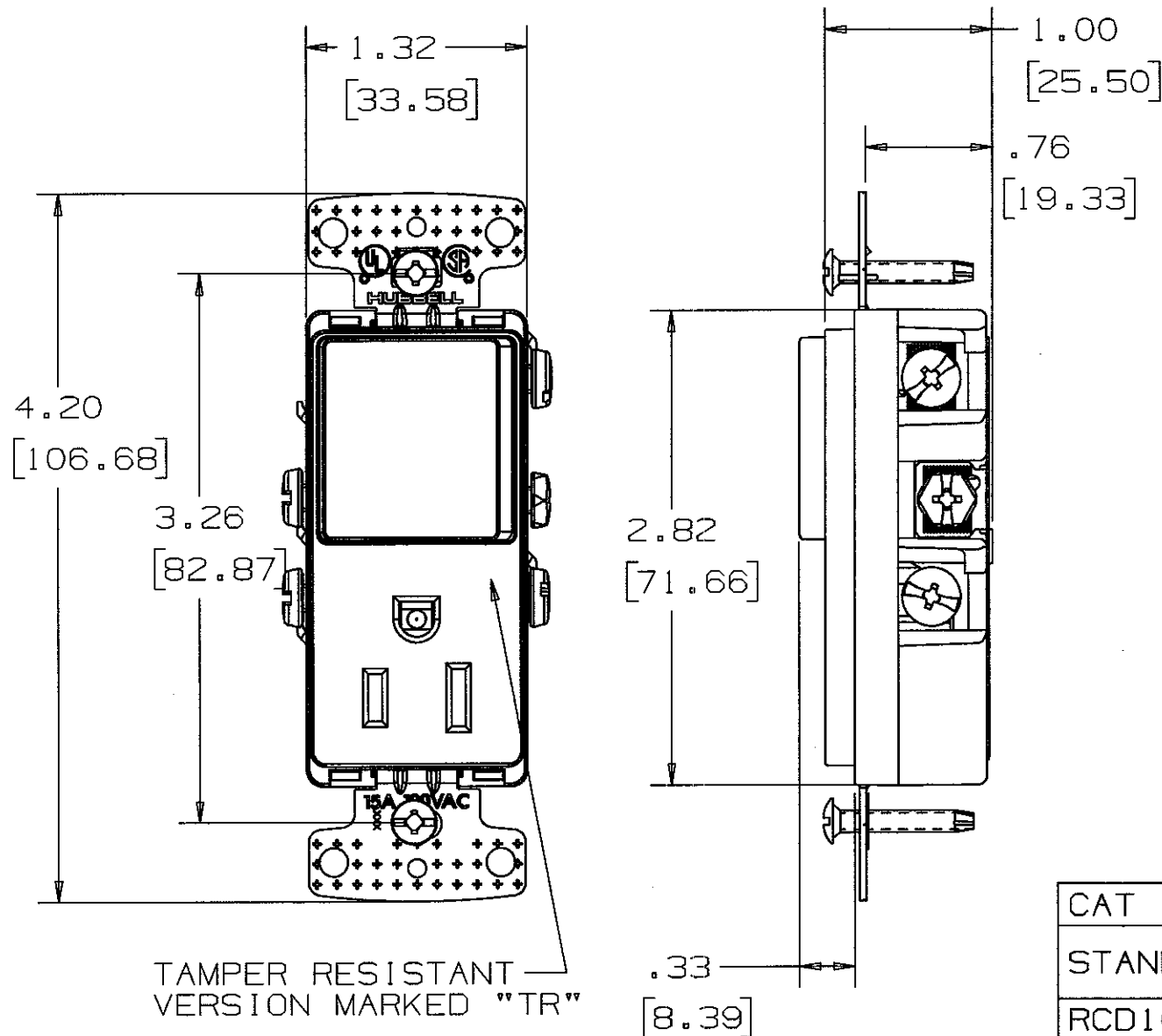
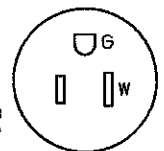

TAMPER RESISTANT  
VERSION MARKED "TR"

DIMENSIONS ARE IN INCHES [MM].

RECEPTICAL CONFIG. AND RATING	SWITCH RATING
 NEMA 5-15R 15A 125V	15A 120VAC

CAT #		COLOR	STYLE
STANDARD	TAMPER RESISTANT		
RCD108	-	BROWN	SINGLE POLE SWITCH W/RECEPT
RCD108I	RCD108ITR	IVORY	
RCD108W	RCD108WTR	WHITE	
RCD108GY	RCD108GYTR	GRAY	
RCD108BK	RCD108BKTR	BLACK	
RCD108AL	RCD108ALTR	ALMOND	
RCD108LA	RCD108LATR	LIGHT ALMOND	
RCD308	-	BROWN	
RCD308I	RCD308ITR	IVORY	
RCD308W	RCD308WTR	WHITE	
RCD308GY	RCD308GYTR	GRAY	
RCD308BK	RCD308BKTR	BLACK	
RCD308LA	RCD308LATR	LIGHT ALMOND	

LIST OF PARTS

DESCRIPTION	MATERIAL	FINISH
BRIDGE	STEEL	
BASE	PLASTIC	ZINC
COVER	PLASTIC	
ROCKER BUTTON	PLASTIC	
DRIVE SCREW	STEEL	ZINC
TERMINALS	BRASS	
GROUNDING SPRING	SS	
SPRING HOUSING	PLASTIC	
WASHER	PLASTIC	
MOUNTING SCREW	STEEL	ZINC
SWITCH CONTACTS	SILVER	
SPRING	STEEL	
ROCKER CONTACT	BRASS	

NO.	DESCRIPTION	APP.	DATE
2	ADDED TAMPER RESISTANT CAT NOS. PER DCN 14434	RK ZDK	01/22/08
1	RELEASED TO PRODUCTION PER DCN 13440	FJ	10/6/06

SYM	REVISIONS	APP	DATE

THE DESIGN AND DIMENSIONS OF THE PRODUCT SHOWN ON THIS DRAWING ARE SUBJECT TO CHANGE WITHOUT NOTICE

TITLE  
15A COMBINATION DECORATOR SWITCH RECEPTACLE

TOLERANCES UNLESS OTHERWISE SPECIFIED FRACTIONS ± 1/64 DECIMALS ± .005 ANGLES ± 2°	WIRING DEVICE-KELLEMS HUBBELL INCORPORATED BRIDGEPORT, CT	
	DR. BY MPF	APP. BY FJ
	TR. BY	SCALE 1/1
	CHK'D BY FJ	DATE 10/3/05