

CFB10G55 / CFB10G55CR  
(RECTANGULAR COVER FOR 5.50" MIN POUR)

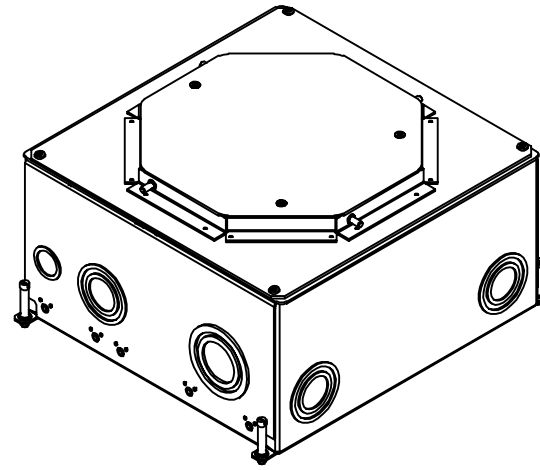

CFB10G55R / CFB10G55RCR  
(ROUND COVER FOR 6.25" MIN POUR)

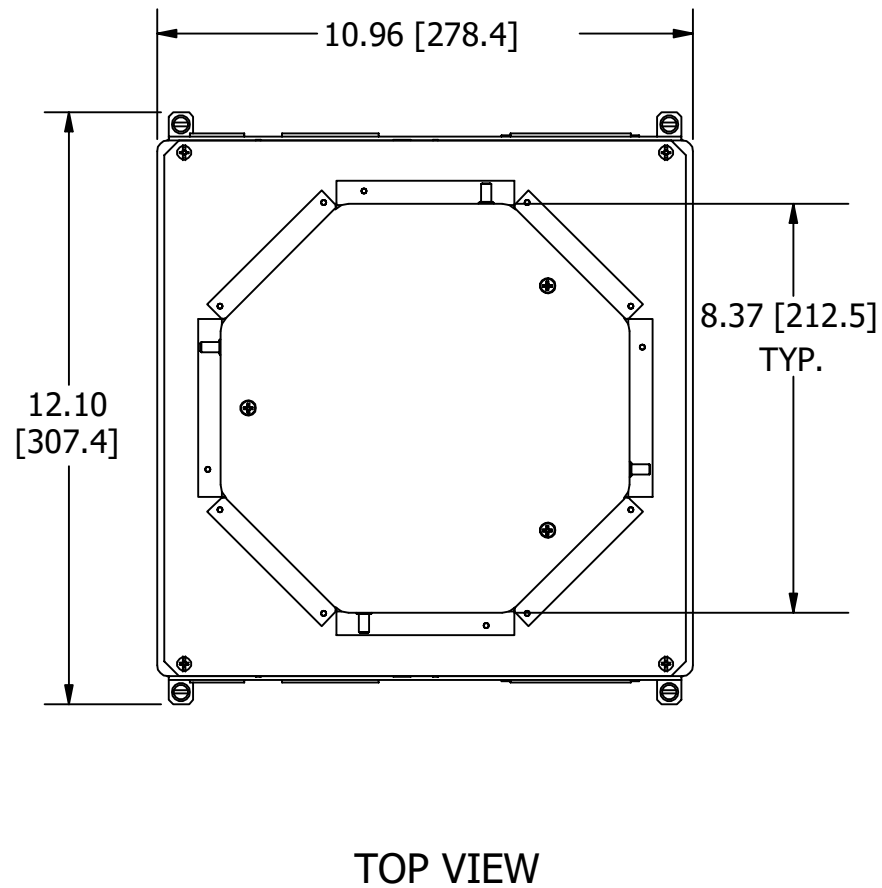
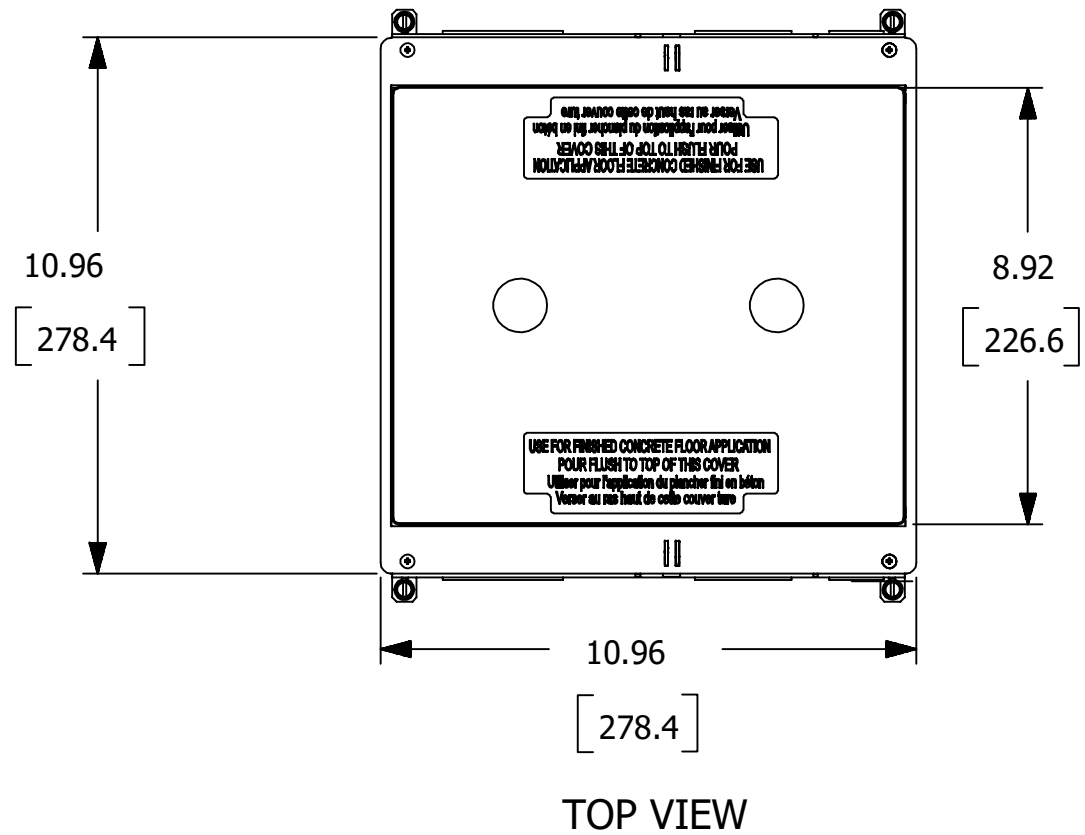

NOTES:

1. CFB10G55 SERIES SUPPLIED WITH RECTANGULAR COVER FOR 5.50 INCH MIN. POUR.
2. CFB6G55R SERIES SUPPLIED WITH ROUND COVER FOR 6.25 INCH MIN. POUR.
3. BOX TYPE WHICH INCLUDES STANDARDS, CORROSION-RESISTANT, CAST IRON.
3. FOLLOW MANUFACTURERS DIRECTIONS AND GUIDELINES FOR THE INSTALLATION AND MOUNTING OF THE FLOOR BOX AND ALL OF THE ASSOCIATED COMPONENTS.

THE DESIGN AND DIMENSIONS OF THE PRODUCT SHOWN ON THIS DRAWING ARE SUBJECT TO CHANGE WITHOUT NOTICE

TITLE  
10 GANG RECESSED FLOOR BOX

TOLERANCES UNLESS OTHERWISE SPECIFIED .XX = ± .01 .XXX = ± .005 ANGLES = ± 2°	WIRING DEVICE-KELLEMS HUBBELL INCORPORATED SHELTON, CT	
	DR. BY	APP. BY
	TR. BY	SCALE
	CHK. BY	DATE

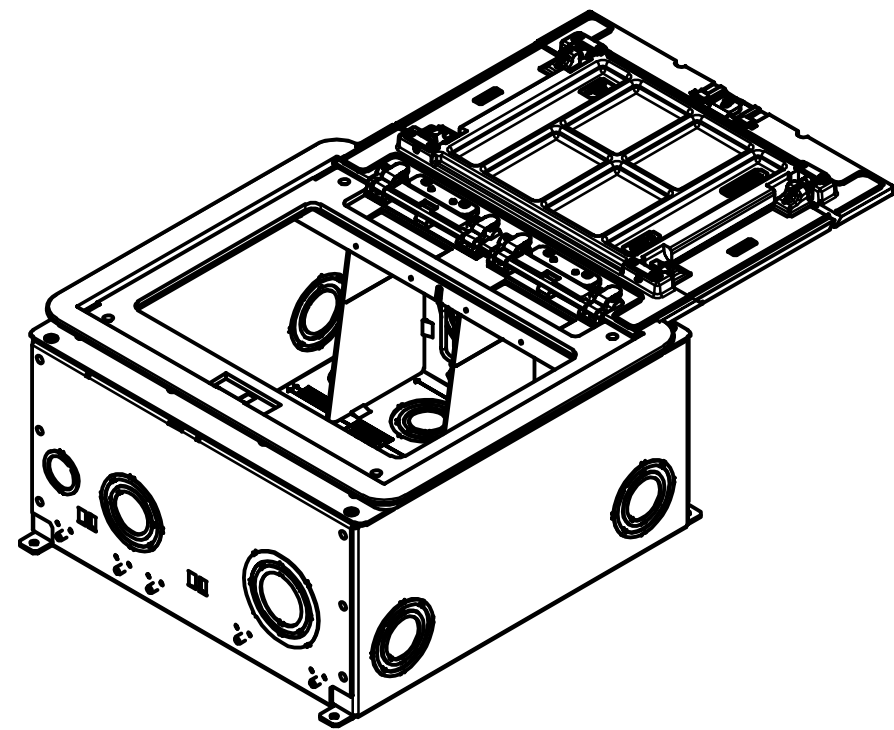

CFB10G55 / CFB10G55CR  
(RECTANGULAR COVER OPEN)

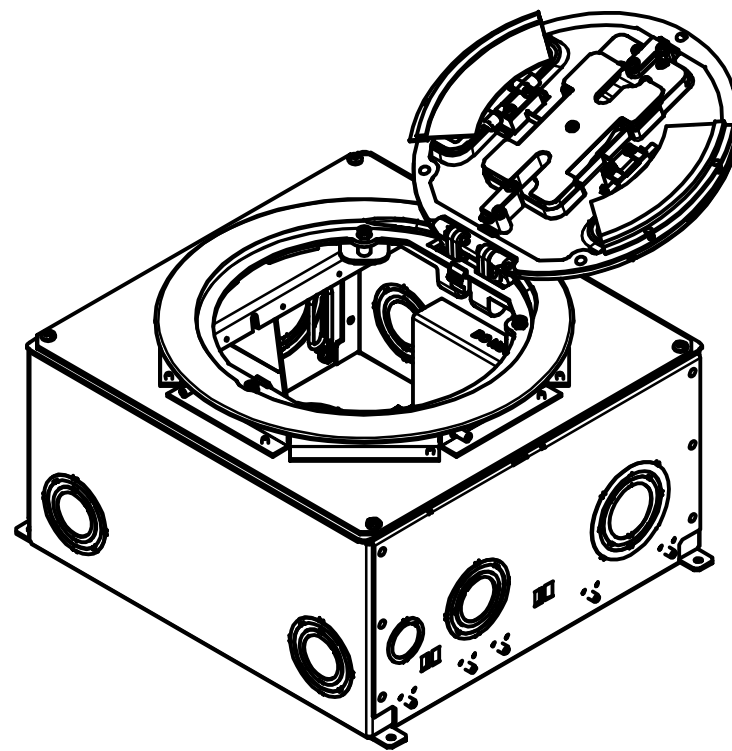

CFB10G55R / CFB10G55RCR  
(ROUND COVER OPEN)

SYSTEM ONE 10 GANG PLATES AND ACCESSORIES

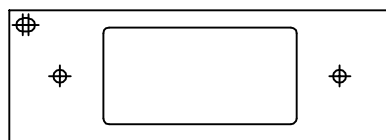

CATALOG NO.	DESCRIPTION:
FB10MPREC	STYLELINE DECORATOR PLATE

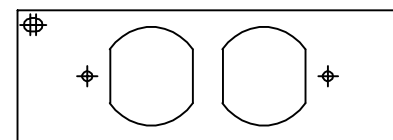

CATALOG NO.	DESCRIPTION:
FB10MPDUP	DUPLEX PLATE

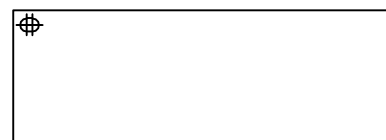

CATALOG NO.	DESCRIPTION:
FB10MPBNK	SINGLE BLANK

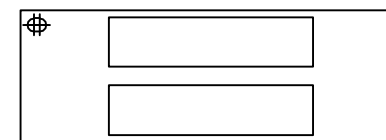

CATALOG NO.	DESCRIPTION:
FB10MPTRAC	SIX ORTRONICS TrackJack®

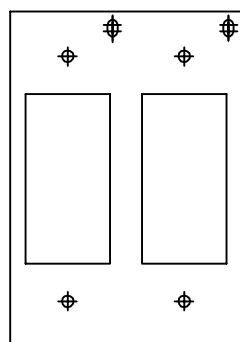

CAT. No.	DESCRIPTION
FB10MP2A	DOUBLE STYLELINE DECORATOR

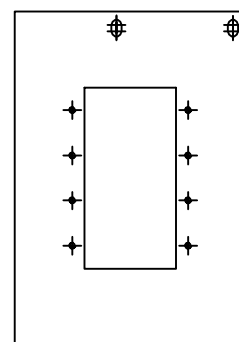

CAT. No.	DESCRIPTION
FB10MPMAAP	4-UNIT EXTRON MAAP

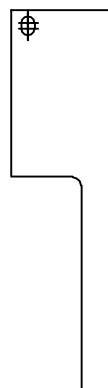

CATALOG NO.	DESCRIPTION:
FB10MPX	WIREWAY SPACER PLATE

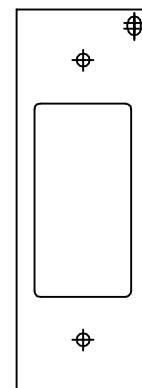

CATALOG NO.	DESCRIPTION:
FB10MPKEY	KEYSTONE PLATE

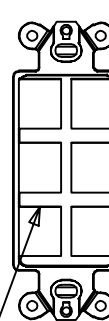

HUBBELL 6-PORT THERMOPLASTIC  
FRAME SUPPLIED. COLOR: GRAY

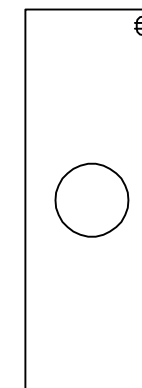

CATALOG NO.	DESCRIPTION:
FB10MPFT	CABLE FEED THRU W/BUSHING

THE DESIGN AND DIMENSIONS OF THE  
PRODUCT SHOWN ON THIS DRAWING ARE  
SUBJECT TO CHANGE WITHOUT NOTICE

TITLE  
10 GANG RECESSED FLOOR BOX

TOLERANCES UNLESS OTHERWISE SPECIFIED  .XX = ± .01 .XXX = ± .005 ANGLES = ± 2°	WIRING DEVICE-KELLEMS HUBBELL INCORPORATED SHELTON, CT	
	DR. BY	APP. BY
	TR. BY	SCALE
	CHK. BY	DATE

SYSTEM ONE 10 GANG PLATES AND ACCESSORIES

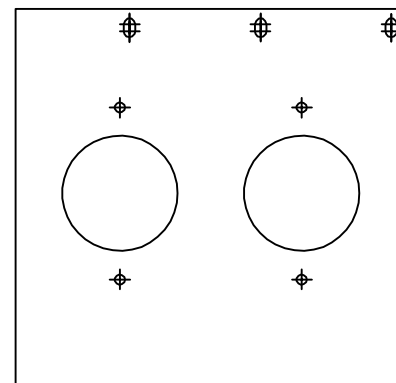
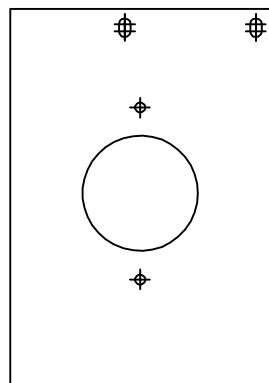
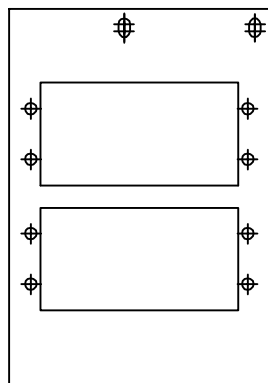
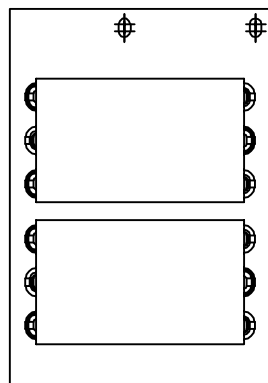

CAT. No.	DESCRIPTION
FB10MP2B	6 UNIT iSTATION®

CAT. No.	DESCRIPTION
FB10MPAAP	4-UNIT EXTRON AAP

CAT. No.	DESCRIPTION
FB10TLA	(1) TWIST-LOCK® OPENING ø1.60 IN
FB10TLX	(1) SIMPLEX OPENING ø1.40 IN

CATALOG No.	DESCRIPTION
FB10TLB	(2) TWIST-LOCK® OPENING ø1.60 IN
FB10TLY	(2) SIMPLEX OPENING ø1.40 IN

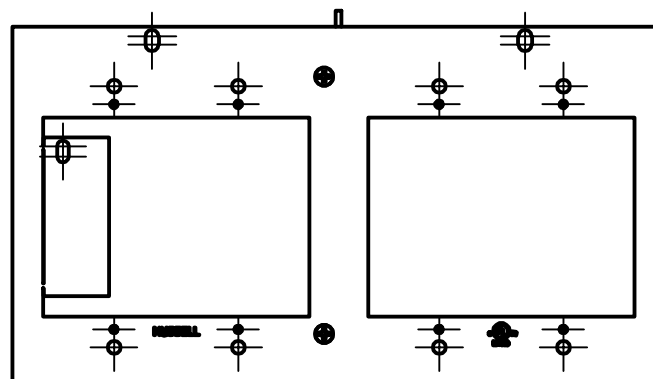
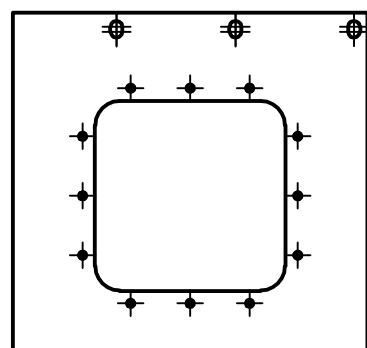
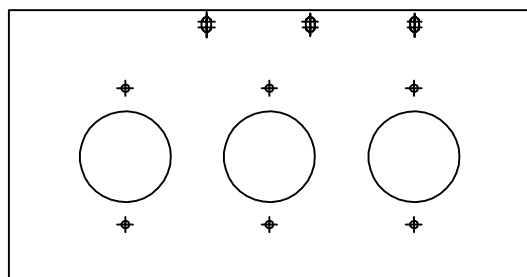

CATALOG No.	DESCRIPTION
FB10TLC	(3) TWIST-LOCK® OPENING ø1.60 IN
FB10TLZ	(3) SIMPLEX OPENING ø1.40 IN

CAT. No.	DESCRIPTION
FB10MP3GAPP	APPLIANCE RECEPTACLE

CAT. No.	DESCRIPTION
FB10MPNEMA2XG	(2) 2-GANG OPENINGS, NEMA SPACING

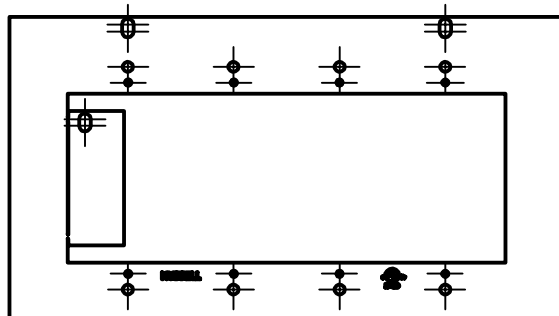

CAT. No.	DESCRIPTION
FB10MPNEMA4G	(4) SINGLE SERVICE OPENINGS, NEMA SPACING

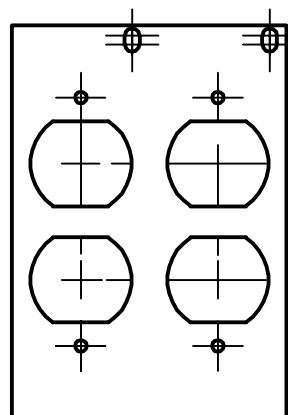

CAT. No.	DESCRIPTION
FB10MP2E	2-GANG DUPLEX

\* THE FLOOR BOXES, COVERS AND SUB-PLATES ARE ALL UL514A & cULus LISTED.  
 \* AVAILABLE IN PRE-WIRED PLATES WHICH REDUCES WIRING AND INSTALLATION TIMES FOR 15A AND 20A JUST FOR FB10MPREC AND FD10MPDUP.  
 \* MOUNTING HARDWARE INCLUDED.

DIMENSION SHEET FOR CAT. NO. CFB10GXX, CFB10GXXR

REPAIRABLE  NON-REPAIRABLE

**B** 10 G RECESSED FLOOR BOX

THE DESIGN AND DIMENSIONS OF THE PRODUCT SHOWN ON THIS DRAWING ARE SUBJECT TO CHANGE WITHOUT NOTICE

TITLE  
10 GANG RECESSED FLOOR BOX

TOLERANCES UNLESS OTHERWISE SPECIFIED	WIRING DEVICE-KELLEMS HUBBELL INCORPORATED SHELTON, CT	
	.XX = ± .01 .XXX = ± .005 ANGLES = ± 2°	DR. BY
	TR. BY	SCALE
	CHK. BY	DATE

SYSTEM ONE 10 GANG RECTANGULAR COVER- SURFACE STYLE

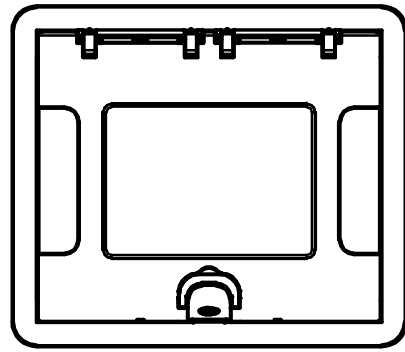

610GCCVRXX (RECESS)

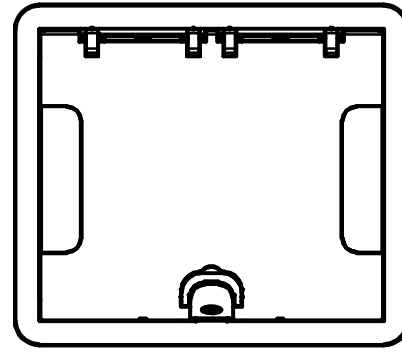

610GCCVRXXC (NO RECESS)

SYSTEM ONE 10 GANG RECTANGULAR COVER- FLUSH STYLE

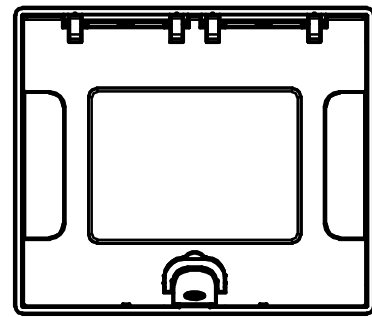

610GTCVRXX (RECESS)

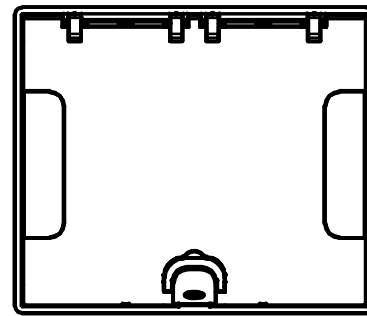

610GTCVRXXC (NO RECESS)

SYSTEM ONE 10 GANG ROUND COVER

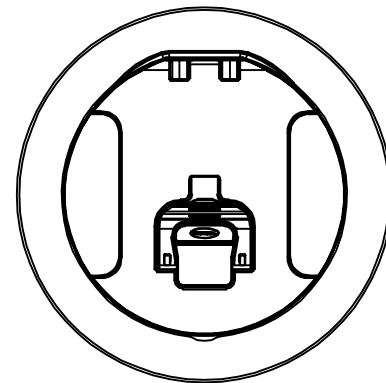

CFBS1R8CVRXXX  
CFBS1R8CVRBLK - BLACK  
CFBS1R8CVRNKL - NICKEL

\* XX INDICATES FLOOR BOX ON THIS PAGE ARE AVAILABLE IN THE FOLLOWING COVER COLOR OPTION AS INDICATED BY THE CATALOG NUMBERS. ALU-ALUMINUM POWDER COAT, BK- BLACK POWDER COAT, BRS- BRASS POWDER COAT, BRZ- BRONZE POWDER COAT, NK- SATIN NICKEL POWDER COAT.

THE DESIGN AND DIMENSIONS OF THE PRODUCT SHOWN ON THIS DRAWING ARE SUBJECT TO CHANGE WITHOUT NOTICE

TITLE  
 10 GANG RECESSED FLOOR BOX

TOLERANCES UNLESS OTHERWISE SPECIFIED .XX = ± .01 .XXX = ± .005 ANGLES = ± 2°	WIRING DEVICE-KELLEMS HUBBELL INCORPORATED SHELTON, CT	
	DR. BY	APP. BY
	TR. BY	SCALE
	CHK. BY	DATE