

COMPONENT LIST

ITEM NO.	DESCRIPTION	MAT'L	COMPONENT NO.	QTY.
1	STRAND	T BRZ	302-01-006	-
2	EYE	CU	342-43-005	2
3	ROD	SST	304-53-016	1
4	EQUALIZER	SST	304-48-010	2
5	TAG	MYLAR		1

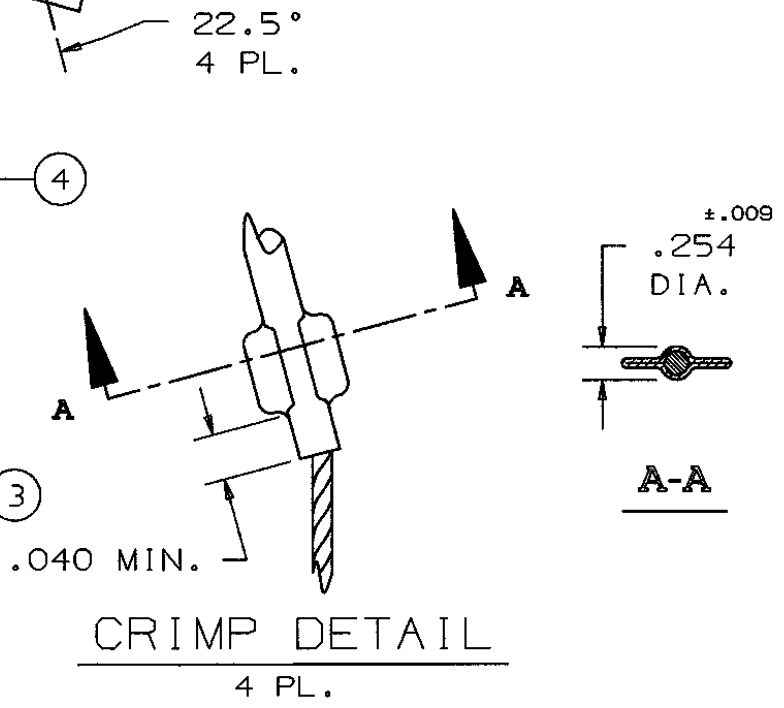
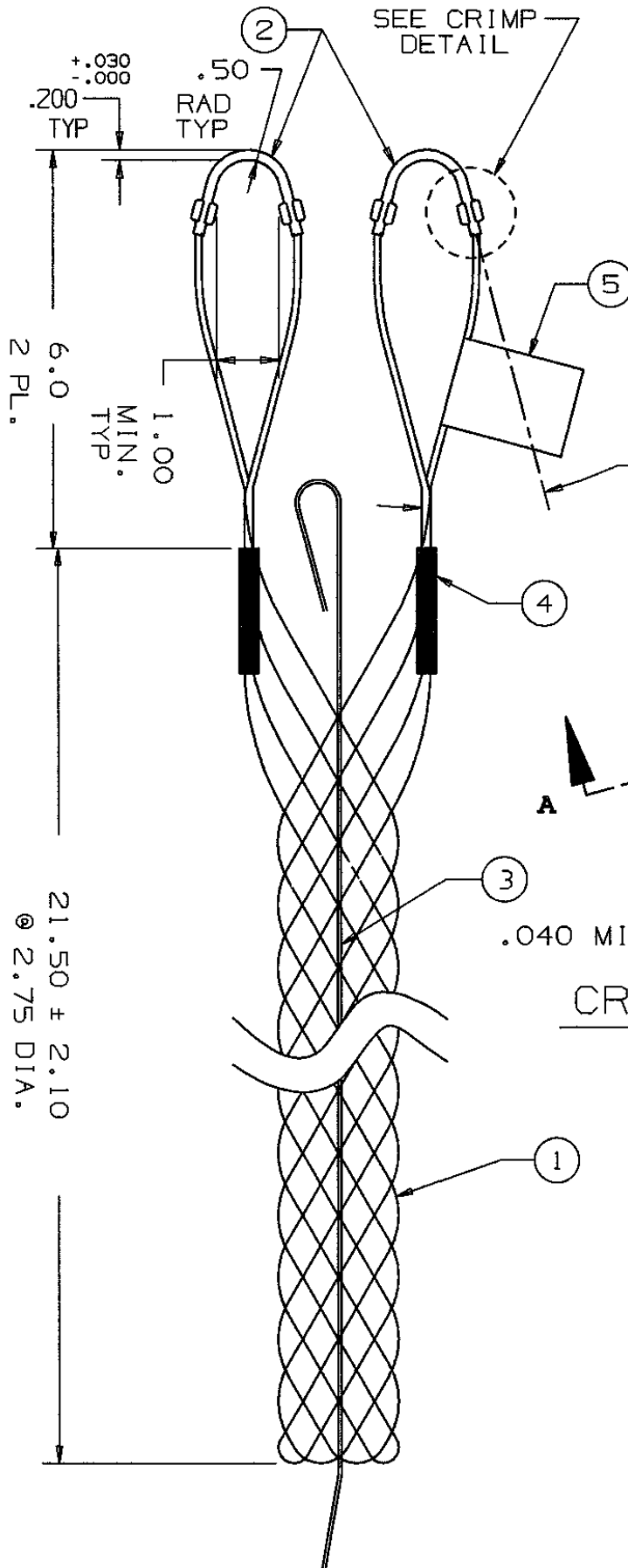

IN ACCEPTING OUR DRAWINGS OR BLUEPRINTS FOR QUOTATION OR OTHER PURPOSES, YOU AGREE NOT TO DISCLOSE TO OTHERS THE IDEAS, INFORMATION, OR DESIGNS THEREIN SHOWN, AND THAT YOU WILL MAKE NO USE OF OUR DRAWINGS OR BLUEPRINTS OR OF THE IDEAS, INFORMATION, OR DESIGNS THEREIN SHOWN WITHOUT OUR PERMISSION.

TITLE GRIP, STD. SUPPORT, SPLIT-ROD CLOSING, SINGLE WEAVE, DOUBLE EYE
DIA. RA 2.50-2.99
APPROX BRK STR. 3260# ±20%

TOLERANCES UNLESS OTHERWISE SPECIFIED .X = ±.5 .XX = ±.05 .XXX = ±.015 ANGLE TOL. ± 2°	HUBBELL INCORPORATED KELLEMS DIVISION STONINGTON, CT	
	DR. BY FBR	APP. BY FFS
PROJECT NO.	TR. BY	SCALE N/A
	CHK. BY JLW	DATE 10-21-93

DR. NO. 022-03-010 REV. N