

DEADFRONT MODIFICATIONS AND PANEL RE-ASSEMBLY

10. Remove any full width plate covering the dead front area for the installed kit.

11. If the installed kit does not completely fill the unit space of a removed module, a dead front filler plate kit is required. Use DFFP3 for 3" gaps and DFFP6 for 6" gaps.

12. Refer to fig. 5. - Install two dead front adaptor plates (item 5) on the outside edges of the kit dead front area, at the kit unit space locating dimension D, as shown. Fasten the plates to the dead front with four 8-32 screws (item 6).

13. Replace the dead front using the hardware removed during disassembly.

14. Refer to fig. 6. - Insert 1" dead front fillers (item 4) into all P3 dead front branch spaces not filled with breakers.

15. Replace the deadfront cover using the hardware removed during disassembly.

16. Tighten all hardware to the specified torque values on the back of the dead front.

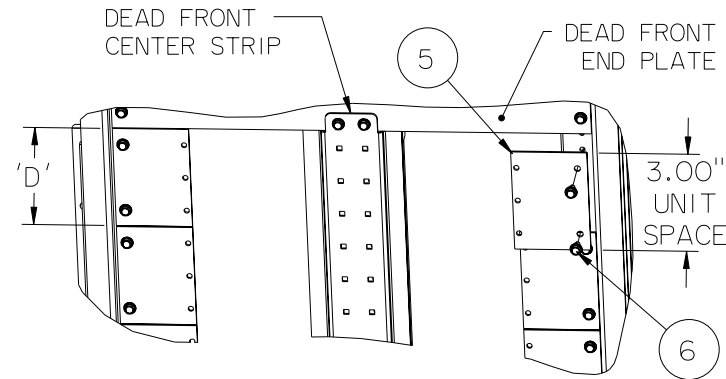

Figure 5

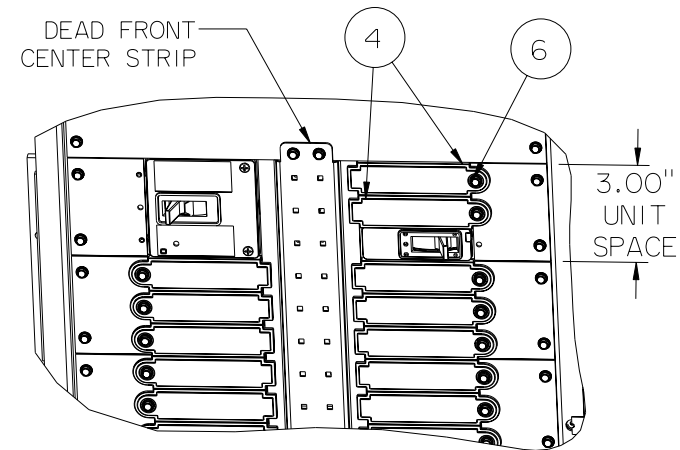

Figure 6

SIEMENS

P3 Panelboard Kit BBKEB32 For Branch Mounting of EB Breakers

Installation
Instructions

Installation Instructions

The following instructions are for installation of Siemens EB (NEB or HEB) circuit breakers as branch devices in Type P3 panelboards. The parts provided in this kit connect EB breakers to 1-phase, or 3-phase systems. The breakers are not included in this kit and must be purchased separately. This kit requires 3" of branch unit space. The dead front will need a blank filler plate if this kit incompletely fills the interior unit space of any removed filler plate or branch module(s). These dead front filler kits are #DFFP3 for a 3" gap and #DFFP6 for a 6" gap.



⚠ DANGER

Hazardous voltage. Will cause death or serious injury.

Keep out. Qualified personnel only. Disconnect and lock off all power before working on this equipment.

1. Lock off power supplying this equipment before working on it.
2. Remove the panelboard front cover and dead front.
3. Refer to fig.1 - For taking unit space measurements in P3 panels, use the neutral barriers if present, or the bus supports in panels without neutrals. Note that unit space starts at the inner surface of a P3 neutral barrier and 0.25" from the inner surface of the P3 bus support.

4. This kit requires 3" of unit space. Determine the location where the kit is to be installed. The kit positioning dimension D in fig. 1, must be a multiple of 3" (0", 3", 6", 9", etc.). These measurements can be taken directly from a P3 bus support, add 0.25" to D (0.25", 3.25", 6.25", 9.25", etc.)

5. If an existing branch module occupies the location chosen for this kit, remove all of its devices, components and parts. If it is a 6" module, the entire 6" of unit space must be cleared.

THIS KIT CONTAINS THE FOLLOWING ITEMS

ITEM #	DESCRIPTION	QTY.
1	EB Breaker Mounting Barrier	1
2	Outer Connector Bus	3
3	Center Connector Bus	1
4	1" Unit Space Dead Front Filler	6
5	P3 Panel Dead Front Adaptor Plate	2
6	8-32 Self-threading Screw	12
7	1/4-20 X 1" Self-threading Screw	3
8	10-24 X 5/8" Self-threading Screw	6

NOTE: Separate instructions are provided for kit installation for each system and panel type. Each application uses some, but not all of the above listed parts. Instructions for breaker installation and panel re-assembly are located on page 3 & 4.

INSTALLATION IN P3 1-PHASE PANELS

6. Refer to fig. 2. - Position the breaker mounting barrier (item 1) so that it fills the 3" unit space for the kit and fasten it to the base rails using two 8-32 screws (item 6). Install the phase connectors (item 2) within the mounting barrier, alternating between the left and right panel bus. The left-right-left connector pattern shown in fig. 2 may be reversed if necessary to continue a connector pattern already in place in the panel. Locate the outer connectors in the mounting base by aligning the center hole in the connectors with the locating pins in the mounting base. Use the upper & lower connectors as a reference guide for placement of the center connector. Fasten the connectors to the panel bus with three 1/4-20 X 1" screws (item 7).

7. Tighten all screws to the torque values specified on the back of the dead front.

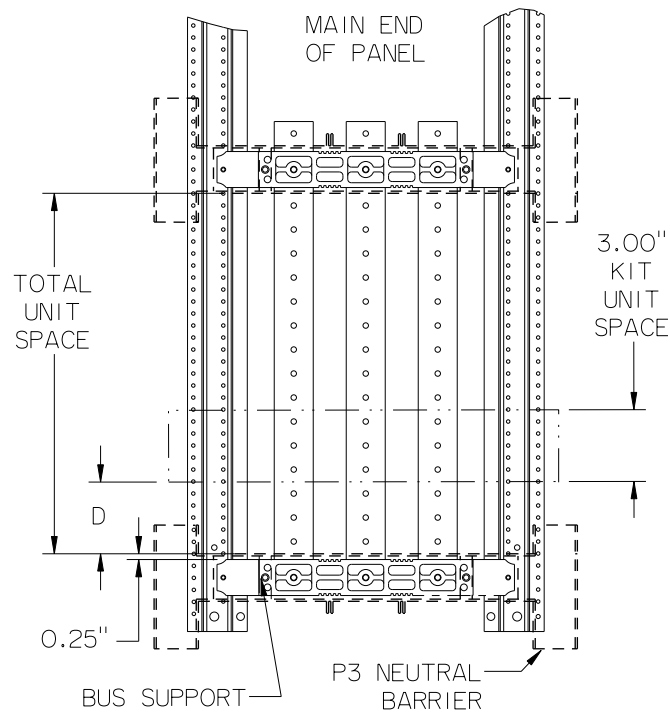

Figure 1

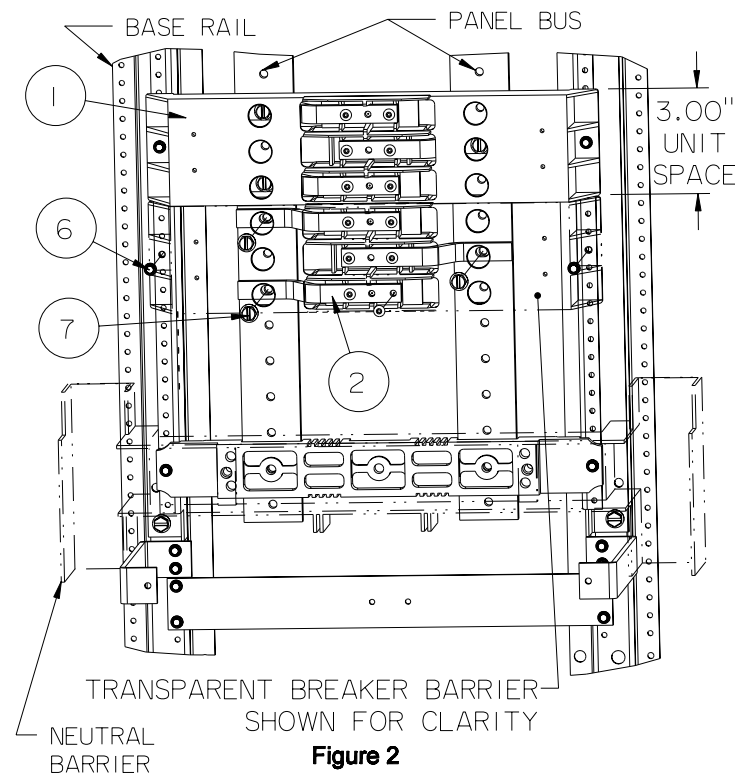

Figure 2

INSTALLATION IN P3 3-PHASE PANELS

6. Refer to fig. 3. - Position the breaker mounting barrier (item 1) so that it fills the 3" unit space for the kit and fasten it to the base rails using two 8-32 screws (item 6). Install the two outer rails connectors (item 2) and the center connector (item 3) within the mounting barrier, as shown. Use the locating pins on the mounting base to aid in aligning the two outer connectors with center hole in the connector bus. Fasten the connectors to the panel bus with three 1/4-20 X 1" screws (item 7).

7. Tighten all screws to the torque values specified on the back of the dead front.

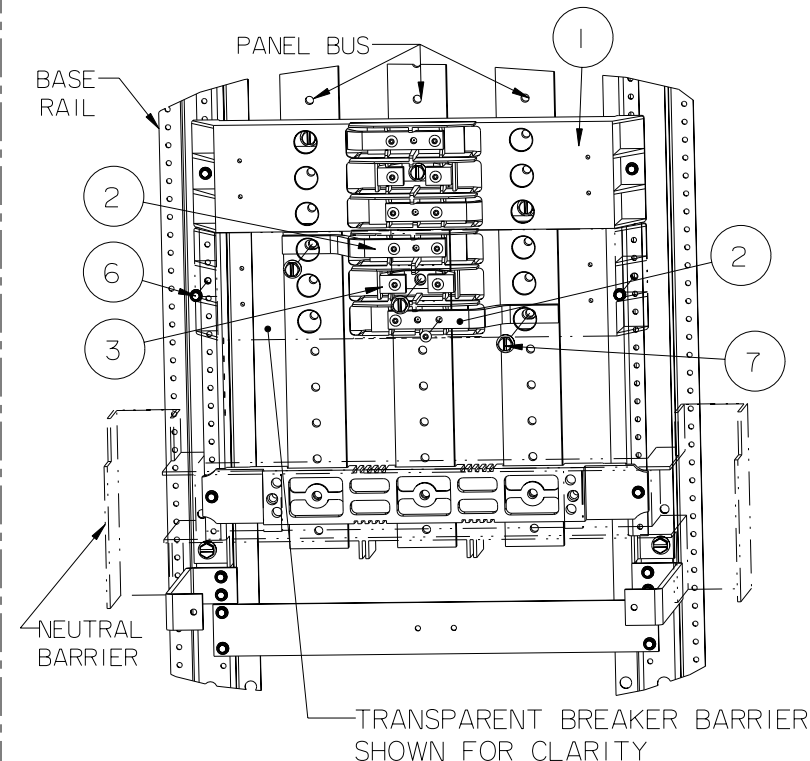

Figure 3

BRANCH BREAKER INSTALLATION - ALL PANELS

8. Refer to fig. 4. - Position each branch breaker so that the line side of the breaker case rests against the center stops on the breaker mtg. barrier. The thru holes located on the load side of the breaker will align with the threaded inserts to the rear of the breaker mounting barrier (item 1). Bring each breaker line stab into contact with its connector bus and align all breaker stab holes with the corresponding connector bus holes.

9. Fasten each breaker line stab to its connector using a 10-24 X 5/8" screw (item 8), and tighten to the torque value specified on the back of the dead front. Secure the breaker to the mounting barrier using the 6-32 X 2 3/4" machine screws supplied with the breaker. Overtightening of these screws can result in the removal of the threaded inserts in the mounting barrier (item 1).

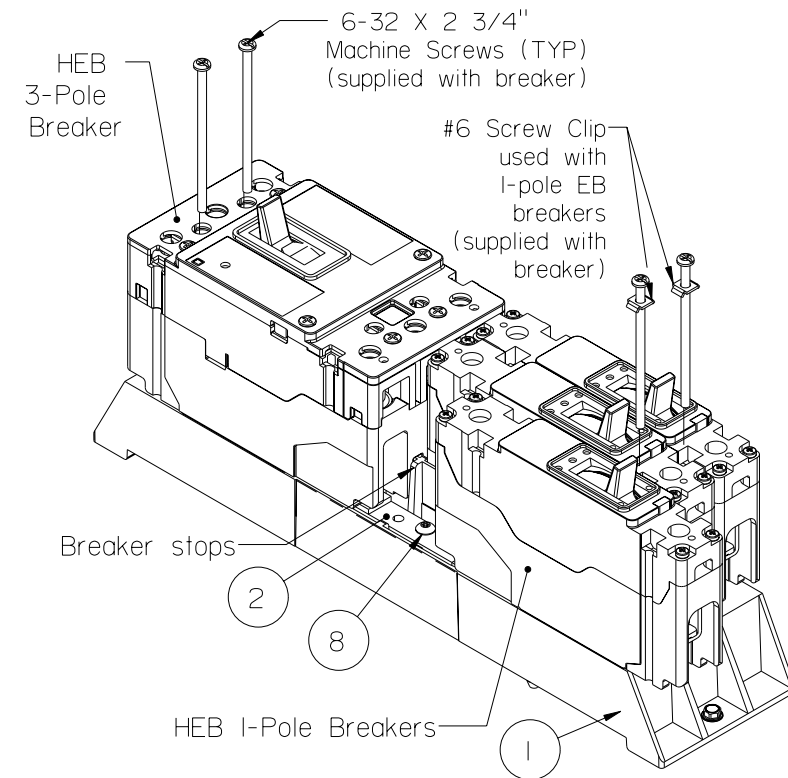

Figure 4