

# SHU | OXFORD™

## COMMERCIAL AND INDUSTRIAL UNIT HEATER



**OXFORD™**  
SERIES | SÉRIE



## THE POWER OF DISPERSION

Stelpro designs heaters for all circumstances. Take the SHU, the large volume heater that is distinguished by its appealing appearance, its manufacturing and its sturdy composition. It is usually installed in large garages, but it is not uncommon for it to be seen in warehouses or any other kind of commercial construction site requiring a generous volume of heat. The SHU works with great ease and has an incredible power scale from 2 kW to 60 kW. What could be better!

### INSTANT HEAT

### PERMANENTLY LUBRICATED MOTOR

### WIDE RANGE OF POWER: 2 KW TO 60 KW

### WALL OR CEILING INSTALLATION BRACKET INCLUDED

### COLOUR

- charcoal

### FINISH

- epoxy-polyester powdercoat

### MANUFACTURING

- heavy-duty, 18-gauge steel cabinet
- adjustable louvers and protective screen
- thermal protection with automatic reset

### MOTOR

- permanently enclosed lubricated ball bearing motor for long-lasting operation

### ELEMENT

- nichrome element produces instant heat

### CONTROL

- connection of multiple units to the same thermostat is possible with a relay kit without transformer (optional) and an external transformer (not provided)

### INSTALLATION

- wall or ceiling mounted with universal mounting bracket (included)
- minimum distance from adjacent walls: 6 in. (2 kW to 30 kW units), 12 in. (40 kW to 60 kW units)
- maximum mounting heights: 8 ft. (2 kW to 10 kW units), 10 ft. (15 kW to 30 kW units), 15 ft. (40 kW to 60 kW units)

### WARRANTY

- three years

#### IDEAL FOR:

warehouse, factory, indoor parking garage, large industrial and commercial spaces

# TECHNICAL SPECIFICATIONS

WITHOUT CONTROL	BUILT-IN THERMOSTAT	240 V CONTROL	24 V CONTROL	VOLTAGE	POWER	FLOW
CODE	CODE	CODE	CODE	VOLTS	KW	CFM
SHU0281CHAR	SHU0281TCHAR	SHU0281CCHAR	SHU0281C24CHAR	208	2	250
---	SHU0283CTCHAR*	SHU0283CCHAR*	SHU0283C24CHAR*	208	2	250
SHU0221CHAR	SHU0221TCHAR	SHU0221CCHAR	SHU0221C24CHAR	240/208	2/1.8	250
---	SHU0231CTCHAR	SHU0231CCHAR	SHU0231C24CHAR	347	2	250
---	SHU0261CTCHAR	SHU0261CCHAR	SHU0261C24CHAR	600	2	250
---	SHU0263CTCHAR*	SHU0263CCHAR*	SHU0263C24CHAR*	600	2	250
SHU0381CHAR	SHU0381TCHAR	SHU0381CCHAR	SHU0381C24CHAR	208	3	250
---	SHU0383CTCHAR*	SHU0383CCHAR*	SHU0383C24CHAR*	208	3	250
SHU0321CHAR	SHU0321TCHAR	SHU0321CCHAR	SHU0321C24CHAR	240/208	3/2.3	250
---	SHU0331CTCHAR	SHU0331CCHAR	SHU0331C24CHAR	347	3	250
---	SHU0361CTCHAR	SHU0361CCHAR	SHU0361C24CHAR	600	3	250
---	SHU0363CTCHAR*	SHU0363CCHAR*	SHU0363C24CHAR*	600	3	250
SHU0481CHAR	SHU0481TCHAR	SHU0481CCHAR	SHU0481C24CHAR	208	4	250
---	SHU0483CTCHAR*	SHU0483CCHAR*	SHU0483C24CHAR*	208	4	250
SHU0421CHAR	SHU0421TCHAR	SHU0421CCHAR	SHU0421C24CHAR	240/208	4/3	250
---	SHU0431CTCHAR	SHU0431CCHAR	SHU0431C24CHAR	347	4	250
---	SHU0461CTCHAR	SHU0461CCHAR	SHU0461C24CHAR	600	4	250
---	SHU0463CTCHAR*	SHU0463CCHAR*	SHU0463C24CHAR*	600	4	250
---	SHU0581TCHAR	SHU0581CCHAR	SHU0581C24CHAR	208	5	450
---	SHU0583CTCHAR*	SHU0583CCHAR*	SHU0583C24CHAR*	208	5	450
SHU0521CHAR	SHU0521TCHAR	SHU0521CCHAR	SHU0521C24CHAR	240/208	5/3.8	450
---	SHU0531CTCHAR	SHU0531CCHAR	SHU0531C24CHAR	347	5	450
---	SHU0561CTCHAR	SHU0561CCHAR	SHU0561C24CHAR	600	5	450
---	SHU0563CTCHAR*	SHU0563CCHAR*	SHU0563C24CHAR*	600	5	450
---	SHU0781CTCHAR	SHU0781CCHAR	SHU0781C24CHAR	208	7.5	700
---	SHU0783CTCHAR*	SHU0783CCHAR*	SHU0783C24CHAR*	208	7.5	700
---	SHU0721CTCHAR	SHU0721CCHAR	SHU0721C24CHAR	240/208	7.5/5.6	700
---	SHU0731CTCHAR	SHU0731CCHAR	SHU0731C24CHAR	347	7.5	700
---	SHU0761CTCHAR	SHU0761CCHAR	SHU0761C24CHAR	600	7.5	700
---	SHU0763CTCHAR*	SHU0763CCHAR*	SHU0763C24CHAR*	600	7.5	700

\* Three-phase unit that can be field-converted to a single phase unit

\* Three-phase unit

# ACCESSORIES

PRODUCT	DESCRIPTION
SHUT1	built-in single pole thermostat (capillary)
SHUT2	built-in double pole thermostat (capillary)
SHUFS*	fan switch
SHUDIS*	disconnect switch [80 A]
SHUC24RX*	relay kit without transformer 24 V (For all SHU, except SHU0521/SHU0581 VOLTS and less)
SHUFS-RCV*	remote control circuit for ventilation mode 240 V

\* Factory installed

# TECHNICAL SPECIFICATIONS

BUILT-IN THERMOSTAT		240 V CONTROL		24 V CONTROL		VOLTAGE	POWER	FLOW
CODE		CODE		CODE		VOLTS	KW	CFM
SHU1081CTCHAR		SHU1081CCHAR		SHU1081C24CHAR		208	10	700
SHU1083CTCHAR*		SHU1083CCHAR*		SHU1083C24CHAR*		208	10	700
SHU1021CTCHAR		SHU1021CCHAR		SHU1021C24CHAR		240/208	10/7.5	700
SHU1031CTCHAR		SHU1031CCHAR		SHU1031C24CHAR		347	10	700
SHU1061CTCHAR		SHU1061CCHAR		SHU1061C24CHAR		600	10	700
SHU1063CTCHAR*		SHU1063CCHAR*		SHU1063C24CHAR*		600	10	700
SHU1581CTCHAR		SHU1581CCHAR		SHU1581C24CHAR		208	15	1300
SHU1583CTCHAR*		SHU1583CCHAR*		SHU1583C24CHAR*		208	15	1300
SHU1521CTCHAR		SHU1521CCHAR		SHU1521C24CHAR		240/208	15/11.3	1300
SHU1531CTCHAR		SHU1531CCHAR		SHU1531C24CHAR		347	15	1300
SHU1561CTCHAR		SHU1561CCHAR		SHU1561C24CHAR		600	15	1300
SHU1563CTCHAR*		SHU1563CCHAR*		SHU1563C24CHAR*		600	15	1300
SHU2081CTCHAR		SHU2081CCHAR		SHU2081C24CHAR		208	20	1300
SHU2083CTCHAR*		SHU2083CCHAR*		SHU2083C24CHAR*		208	20	1300
SHU2021CTCHAR		SHU2021CCHAR		SHU2021C24CHAR		240/208	20/15	1300
SHU2031CTCHAR		SHU2031CCHAR		SHU2031C24CHAR		347	20	1300
SHU2063CTCHAR*		SHU2063CCHAR*		SHU2063C24CHAR*		600	20	1300
SHU2583CTCHAR*		SHU2583CCHAR*		SHU2583C24CHAR*		208	25	1300
SHU2563CTCHAR*		SHU2563CCHAR*		SHU2563C24CHAR*		600	25	1300
SHU3083CTCHAR*		SHU3083CCHAR*		SHU3083C24CHAR*		208	30	1400
SHU3063CTCHAR*		SHU3063CCHAR*		SHU3063C24CHAR*		600	30	1400
SHU4063CTCHAR*		SHU4063CCHAR*		SHU4063C24CHAR*		600	40	2100
SHU5063CTCHAR*		SHU5063CCHAR*		SHU5063C24CHAR*		600	50	2100
SHU6063CTCHAR*		SHU6063CCHAR*		SHU6063C24CHAR*		600	60	2100

\* Three-phase unit that can be field-converted to a single phase unit.

\* Three-phase unit

## THROW DISTANCE AND HEAT RISE

UNITS	THROW DISTANCE		HEAT RISE		
	KW	M	FT	°C	°F
2	8.5	28	17	31	
3	8.5	28	35	62	
4	8.5	28	52	93	
5	9.4	31	55	99	
7.5	9.4	31	54	97	
10	9.4	31	85	153	
15	10.7	35	52	93	
20	11.3	37	89	160	
25	10.2	33'6"	133	240	
30	10.7	35	135	243	
40	10.7	35	132	237	
50	10.7	35	141	254	
60	10.7	35	156	280	

# TECHNICAL DRAWINGS

## 2 KW TO 10 KW UNITS

weight: approx. 40 lb (18 kg)

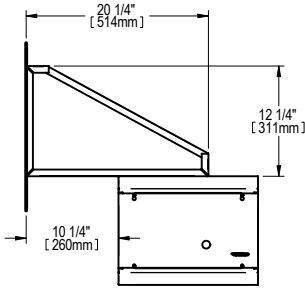

LEFT SIDE

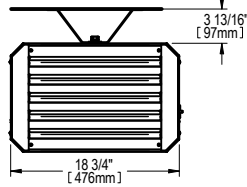

FRONT

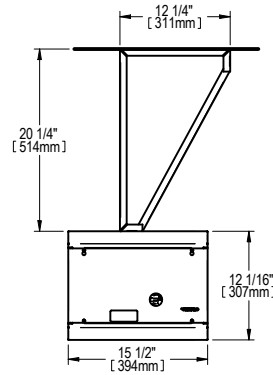

RIGHT SIDE

## 15 KW TO 30 KW UNITS

weight: approx. 67 lb (30 kg)

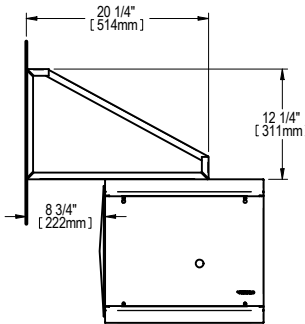

LEFT SIDE

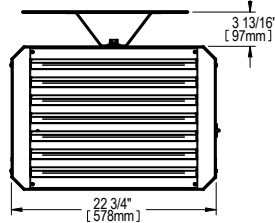

FRONT

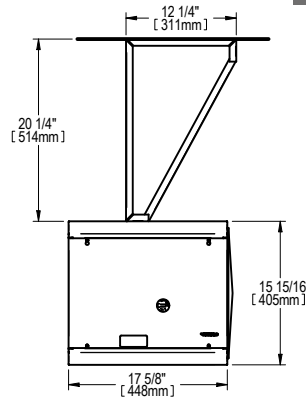

RIGHT SIDE

## 40 KW TO 60 KW UNITS

weight: approx. 100 lb (45 kg)

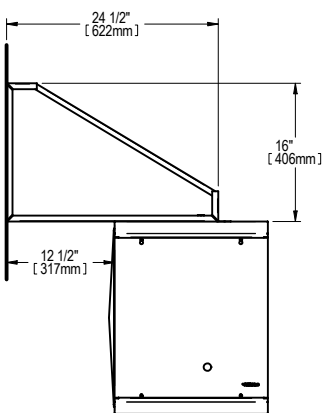

LEFT SIDE

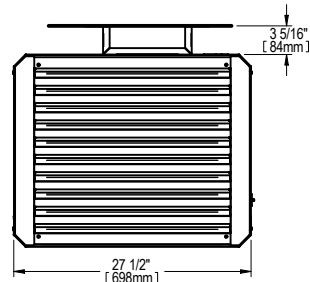

FRONT

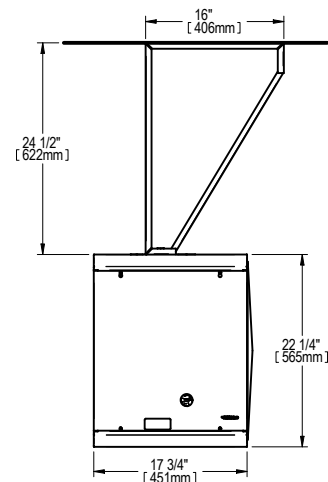

RIGHT SIDE