

M-11735 1

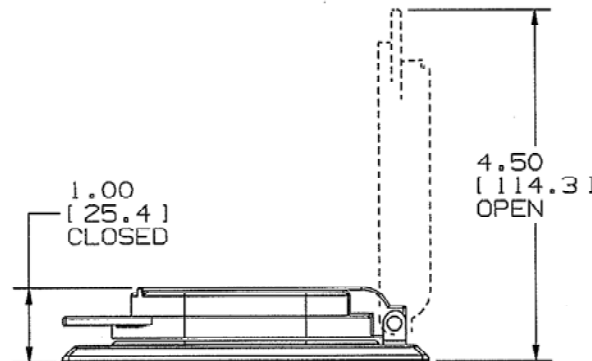
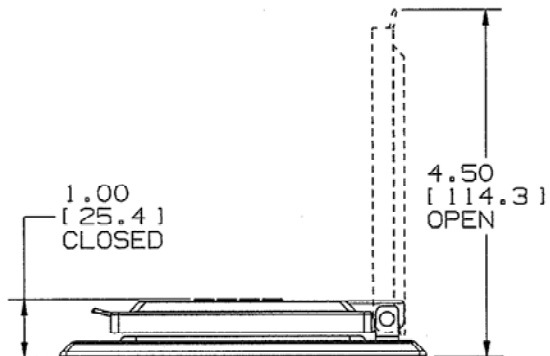
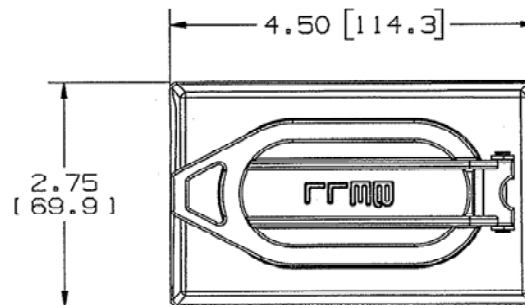
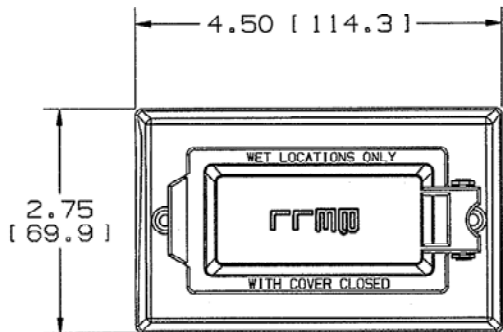

CAT. NO. RW51040  
GFCI OPENING  
VERTICAL MOUNT

CAT. NO. RW51470  
DUPLX OPENING  
VERTICAL MOUNT

PRODUCT INCLUDES FOLLOWING ITEMS:

1. LID ASSEMBLED TO COVER.
2. FOAM GASKET MATERIAL FOR WEATHERTITE SEAL.
3. ASSEMBLY HARDWARE CONSISTING OF MTG. SCREWS PACKAGED IN A POLYBAG FOR DEVICE AND COVER MOUNTING.
4. PRODUCT IDENTIFICATION CARD, INCLUDES INSTALLATION INSTRUCTIONS.
5. PRODUCT COMPLETELY WRAPPED IN CELLOPHANE.
6. DIMENSIONS IN INCHES (MM).

LIST OF PARTS

DESCRIPTION	MATERIAL	FINISH
RECEPT. COVER	ALUMINUM	GRAY
MTG. SCREWS	STEEL	
GASKET	FOAM	BLACK

SYM	REVISIONS	APP	DATE
1	NEW RELEASE PER DCN 18843 SPN	DJP	10/8/10

THE DESIGN AND DIMENSIONS OF THE PRODUCT SHOWN ON THIS DRAWING ARE SUBJECT TO CHANGE WITHOUT NOTICE

TITLE  
WP COVERS  
1G SINGLE RECEPTACLE  
VERTICAL MOUNTING

TOLERANCES UNLESS OTHERWISE SPECIFIED

FRACTIONS	± 1/64
DECIMALS	± .005
ANGLES	± 2°

WIRING DEVICE-KELLEMS HUBBELL INCORPORATED BRIDGEPORT, CT

DR. BY SPN	APP. BY DJP
TR. BY	SCALE NONE
CHK'D BY DJP	DATE 10/8/10