

SIEMENS

SIMATIC NET

S7-1200 - PROFIBUS CM 1243-5

Operating Instructions

Preface

<u>Application and properties</u>	1
<u>Displays and connectors</u>	2
<u>Installing, connecting up and commissioning</u>	3
<u>Configuration and programming</u>	4
<u>Operating the module</u>	5
<u>Technical specifications</u>	6
<u>Dimension drawings</u>	A
<u>Approvals</u>	B
<u>References</u>	C
<u>Training, Service & Support</u>	D

Legal information

Warning notice system

This manual contains notices you have to observe in order to ensure your personal safety, as well as to prevent damage to property. The notices referring to your personal safety are highlighted in the manual by a safety alert symbol, notices referring only to property damage have no safety alert symbol. These notices shown below are graded according to the degree of danger.

⚠ DANGER
indicates that death or severe personal injury will result if proper precautions are not taken.
⚠ WARNING
indicates that death or severe personal injury may result if proper precautions are not taken.
⚠ CAUTION
with a safety alert symbol, indicates that minor personal injury can result if proper precautions are not taken.
CAUTION
without a safety alert symbol, indicates that property damage can result if proper precautions are not taken.
NOTICE
indicates that an unintended result or situation can occur if the relevant information is not taken into account.

If more than one degree of danger is present, the warning notice representing the highest degree of danger will be used. A notice warning of injury to persons with a safety alert symbol may also include a warning relating to property damage.

Qualified Personnel

The product/system described in this documentation may be operated only by **personnel qualified** for the specific task in accordance with the relevant documentation, in particular its warning notices and safety instructions. Qualified personnel are those who, based on their training and experience, are capable of identifying risks and avoiding potential hazards when working with these products/systems.

Proper use of Siemens products

Note the following:

⚠ WARNING
Siemens products may only be used for the applications described in the catalog and in the relevant technical documentation. If products and components from other manufacturers are used, these must be recommended or approved by Siemens. Proper transport, storage, installation, assembly, commissioning, operation and maintenance are required to ensure that the products operate safely and without any problems. The permissible ambient conditions must be complied with. The information in the relevant documentation must be observed.

Trademarks

All names identified by ® are registered trademarks of Siemens AG. The remaining trademarks in this publication may be trademarks whose use by third parties for their own purposes could violate the rights of the owner.

Disclaimer of Liability

We have reviewed the contents of this publication to ensure consistency with the hardware and software described. Since variance cannot be precluded entirely, we cannot guarantee full consistency. However, the information in this publication is reviewed regularly and any necessary corrections are included in subsequent editions.

Preface

Validity of this manual

This document contains information on the following product:

CM 1243-5

Order number 6GK7 243-5DX30-0XE0

Hardware product version 1, firmware version V1.2

The device is the communications module for the PROFIBUS DP master function for the SIMATIC S7-1200.



Figure 1 CM 1243-5

At the top right behind the hinged cover of the module housing, you will see the hardware product version printed as a placeholder "X" (for example X 2 3 4). In this case, "X" would be the placeholder for hardware product version 1.

Product name

In this document, the term "CM" is also used instead of the full product name "CM 1243-5".

New in this release

New firmware version with bugs fixed and expanded configuration limits. You will find the configuration limits in the section Performance data (Page 9). You will find the necessary requirements in the section Requirements for operation (Page 10).

Replaced documentation

This manual replaces the manual release 09/2011.

Current manual release on the Internet

You will also find the current version of this manual on the Internet pages of Siemens Automation Customer Support under the following entry ID:

49851842 (<http://support.automation.siemens.com/WWW/view/en/49851842>)

Purpose of the manual

This manual describes the properties of this module and supports you when installing and commissioning the device.

The necessary configuration steps are described in the form of an overview.

You will also find instructions for operation and maintenance and information on the diagnostics options of the device.

Required experience

To install, commission and operate the CM, you require experience in the following areas:

- Automation engineering
- Setting up the SIMATIC S7-1200
- SIMATIC STEP 7
- Data transfer with PROFIBUS

Further information

You will find an overview of further reading and references in the Appendix of this manual.

You will also find information about training, Service & Support and who to contact in the Appendix of this manual.

License conditions

NOTICE
Open source software
Read the license conditions for open source software carefully before using the product. The acceptance of the disclaimers of liability and warranty it contains is a clear precondition of the use of open source software.
You will find license conditions in the document "DOC_OSS-S7-CM-CP_74.pdf" on the supplied data medium with the product documentation.

Table of contents

	Preface	3
1	Application and properties	7
1.1	Connecting the S7-1200 to PROFIBUS.....	7
1.2	Communications services of the CM	7
1.3	Performance data	9
1.4	Requirements for operation	10
1.5	Configuration examples for PROFIBUS	11
2	Displays and connectors	13
2.1	Opening the covers of the housing	13
2.2	LEDs	14
2.3	Electrical connections	17
3	Installing, connecting up and commissioning	19
3.1	Warning overvoltage protection	21
3.2	Installing and commissioning the CM 1243-5.....	21
3.3	Pin assignment of the socket for the external power supply	25
3.4	Pinout of the D-sub socket.....	26
4	Configuration and programming	27
4.1	Configuration.....	27
4.2	Programming.....	28
5	Operating the module	29
5.1	Note on operation	29
5.2	Diagnostics.....	29
5.3	Downloading firmware	30
5.4	Module replacement	30
6	Technical specifications	31
A	Dimension drawings	33
B	Approvals	35
C	References	41
D	Training, Service & Support	43
	Glossary	45
	Index	49

Application and properties

1.1 Connecting the S7-1200 to PROFIBUS

Connecting the S7-1200 to PROFIBUS DP

The S7-1200 can be connected to a PROFIBUS fieldbus system with the following communications modules:

- CM 1242-5
Operates as DP slave
- CM 1243-5
Operates as DP master class 1

If a CM 1242-5 and a CM 1243-5 are installed together, an S7-1200 can perform the following tasks simultaneously:

- Slave of a higher-level DP master system
and
- Master of a lower-level DP master system

1.2 Communications services of the CM

Bus protocol

PROFIBUS communication with the S7-1200 CMs is based on the PROFIBUS DP-V1 protocol. The supported functions and restrictions are described below.

Possible DP slaves for the DP master CM 1243-5

With the DP master module CM 1243-5, the S7-1200 can communicate with the following DP-V0/V1 slaves:

- Distributed I/O SIMATIC ET200
- S7-1200 CPUs with CM 1242-5
- S7-200 CPUs with PROFIBUS DP module EM 277
- SINAMICS converter
- Drives and actuators from various vendors
- Sensors of various vendors
- S7-300/400 CPU with PROFIBUS interface

- S7-300/400 with PROFIBUS CP (for example CP 342-5)
- SIMATIC PC stations with PROFIBUS CP

Types of communication with the CM 1243-5 in DP-V1

The following types of communication are available with DP-V1:

- **Cyclic communication**

The CM supports cyclic communication for the transfer of process data between DP slave and DP master.

Cyclic communication is handled by the operating system of the CPU. No instructions or software blocks are required for this. The I/O data is read or written directly from/to the process image of the CPU.

- **Acyclic communication**

The CM also supports acyclic communication:

- The "RALRM" instruction is available for receiving interrupts of the DP slaves.
- The "RDREC" and "WRREC" instructions are available for transferring configuration, diagnostics or I/O data.

Functions not supported by the CM 1243-5:

- SYNC / FREEZE
- Get_Master_Diag

Other communications services of the CM 1243-5

The CM 1243-5 supports the following additional communications services:

- **S7 communication**

- PUT/GET services

The DP master functions as a client and server for queries from other S7 controllers or PCs via PROFIBUS.

- PG/OP communication

The PG functions allow the downloading of configuration data and user programs from a PG and the transfer of diagnostics data to a PG.

Possible communications partners for OP communication are HMI panels, SIMATIC panel PCs with WinCC flexible or SCADA systems that support S7 communication.

1.3 Performance data

Number of CPs/CMs that can be plugged in per S7-1200 station

You can configure a maximum of three CMs/CPs per station. The maximum number of DP master modules depends on the firmware version of the CPU in the master station:

- CM 1243-5 + CPU with firmware version V2.x: Maximum of 1 DP master (CM 1243-5)
- CM 1243-5 + CPU with firmware version V3.x: Maximum of 3 DP masters (CM 1243-5)

Transmission speeds of the CM 1243-5

As the transmission speed on PROFIBUS, values of 9.6 kbps to 12 Mbps are permitted for the CM.

Characteristic data of the DP interface of the CM 1243-5

- **Number of operable DP slaves**

The number of DP slaves that can be operated with the DP master depends on the STEP 7 version, the firmware version of the CPU in the master station and the firmware version of the CM 1243-5:

- CM 1243-5 with firmware version V1.2: Maximum of 32 DP slaves
- CM 1243-5 with firmware version V1.0/V1.1: Maximum of 16 DP slaves

You will find the required STEP 7 version and firmware version of the CPU in the section Requirements for operation (Page 10).

In conjunction with a CPU with firmware version 2.x, the maximum number of operable DP slaves is reduced by the following modules or nodes:

- CM 1242-5 slave modules plugged into the station of the DP Master
- PROFINET IO devices connected to the station of the DP Master

Example:

The DP master module CM 1243-5 is plugged into the station.

There are also two CM 1242-5 DP slave modules plugged into the station.

5 PROFINET IO devices are also connected to the CPU.

In this case, the maximum number of DP slaves that can be operated with the CM 1243-5 is 25. ($32 - 2 - 5 = 25$)

- **Number of operable slots**

Total number of operable slots: Maximum 256

Any distribution of the slots as I slots and Q slots is permitted.

Note

Bi-directional slots are counted double.

- **Data areas of the DP master**
 - Size of the DP data areas of the DP master: Max. 1024 bytes
 - Input area of the DP master in total: Max. 512 bytes
 - Output area of the DP master in total: Max. 512 bytes
- **Data areas of the DP slaves**
 - Maximum size of the DP data areas of the DP slaves
 - Input area per DP slave: Max. 244 bytes
 - Output area per DP slave: Max. 244 bytes
 - Diagnostics data area per DP slave: Max. 244 bytes

Characteristic data of S7 communication

- Number of possible connections for S7 communication in total: 8
 - Of which maximum:
 - Configured connections for PUT/GET services: 4
 - PG/OP connections: 4
- User data per frame
 - PUT: Max. 209 bytes
 - GET: Max. 222 bytes

1.4 Requirements for operation

Configuration tool

To configure the module, the following configuration tool is required:
STEP 7 as of version V11.0. For the precise version, refer to the following table.

CPUs of the S7-1200

Use of PROFIBUS functionalities with the S7-1200 requires CPUs with firmware versions 2.0 or higher in the master station. For the precise version, refer to the following table.

Supported functions depending on the firmware and STEP 7 versions

Required components	Supported functions
CM 1243-5 with firmware version V1.x ** + 1200-CPU with firmware version V2.0 + STEP 7 V11.0	All functions and the reduced configuration limits are supported. *
CM 1243-5 with firmware version V1.2 + 1200-CPU with firmware version V3.0 + STEP 7 V11.0 + Service Pack 2 + Update 2	All functions and the current configuration limits are supported. *

* You will find the relevant configuration limits in the section Performance data (Page 9).

** Regardless of the configuration limits, the CM should be operated with the newer firmware version V1.2.

1.5 Configuration examples for PROFIBUS

Below, you will find examples of configurations in which the CM 1242-5 is used as a DP slave and the CM 1243-5 is used as a DP master.

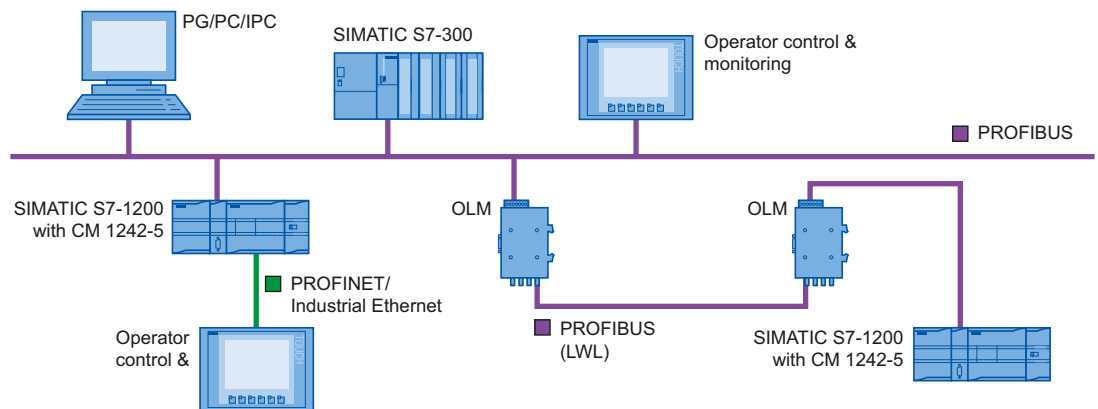

Figure 1-1 Configuration example with a CM 1242-5 as PROFIBUS slave

1.5 Configuration examples for PROFIBUS

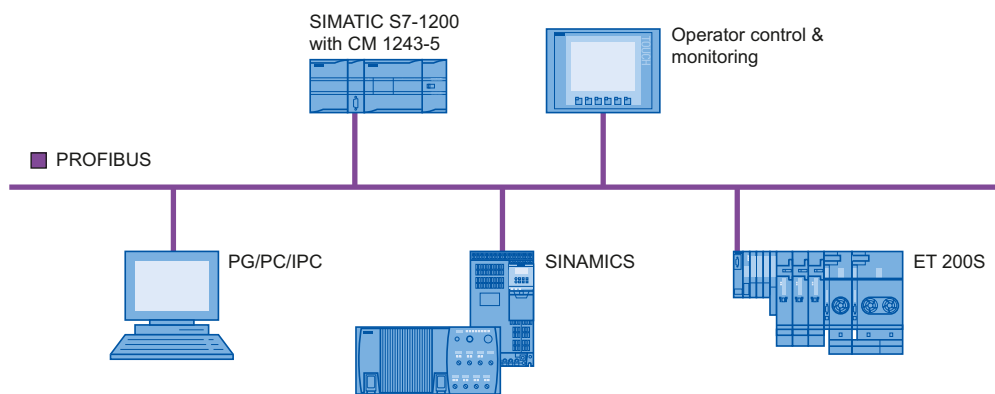

Figure 1-2 Configuration example with a CM 1243-5 as PROFIBUS master

Displays and connectors

2.1 Opening the covers of the housing

Location of the display elements and the electrical connectors

The LEDs for the detailed display of the module statuses are located behind the upper cover of the module housing.

The terminals for the power supply are located on the top of the module.

The PROFIBUS connector is located behind the lower cover of the module.

Opening the covers of the housing

Open the upper or lower cover of the housing by pulling it down or up as shown in the illustration. The covers extend beyond the housing to give you a grip.

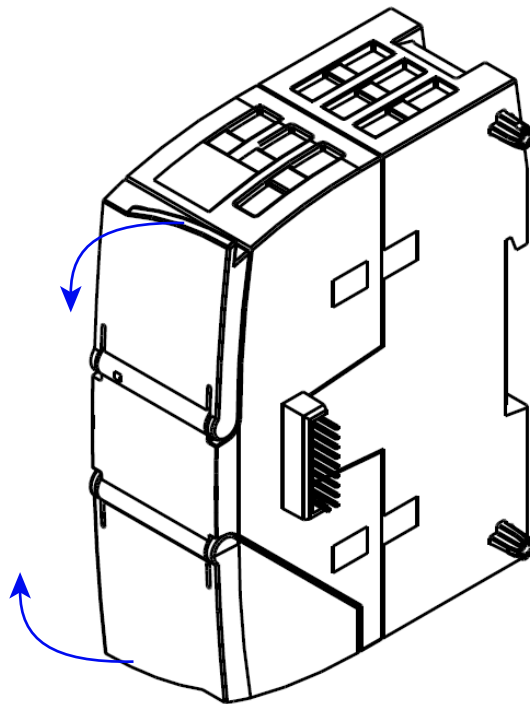

Figure 2-1 Opening the covers of the housing

2.2 LEDs

LEDs of the module

The module has various LEDs for displaying the status:

- LED on the front panel

The "DIAG" LED that is always visible shows the basic statuses of the module.



Table 2- 1 LED on the front panel

LED / colors	Name	Meaning
 red / green	DIAG	Display of the basic status of the module

- LEDs below the upper cover of the housing

Open the upper housing cover. The LEDs here provide more detailed information on the module status.

Table 2- 2 LEDs below the upper cover of the housing





LED / colors	Name	Meaning
 yellow / green	RUN/STOP	Details on the operational and communications status of the module
 red	ERROR	Group error
	- not used -	-
	- not used -	-

NOTICE
LED colors when the module starts up
When the module starts up, all its LEDs are lit for a short time. Multicolored LEDs display a color mixture. At this point in time, the color of the LEDs is not clear.

Display of the operating and communication status

The LED symbols in the following tables have the following significance:

Table 2- 3 Meaning of the LED symbols

Symbol					-
LED status	OFF	ON (steady light)	Flashing, one color	Flashing yellow-green	Not relevant

The LEDs indicate the operating and communications status of the module according to the following scheme:

Table 2- 4 Display of the basic states of the module by the "DIAG" LED























DIAG (red / green)	Meaning	Comment
	Power OFF	
 green	RUN without errors	
 flashing green	<ul style="list-style-type: none"> • Startup • STOP without errors • No project data • Firmware update 	The individual states are signaled by the RUN/STOP and ERROR LEDs (see below).
 flashing red	Problem / error	The individual states are signaled by the RUN/STOP and ERROR LEDs (see below).

Table 2- 5 Display schemes for detailed module statuses

DIAG (red / green)	-	RUN/STOP (yellow / green)	ERROR (red)	Meaning
Detailed status schemes				
 green				RUN without errors, Exchange of user data with DP master
 flashing green				<ul style="list-style-type: none"> Stopped (STOP) without errors No project data available
 flashing green				Starting up (STOP → RUN)
 flashing green				Loading firmware (The RUN/STOP and ERROR LEDs flash alternately.)
 flashing red				RUN with PROFIBUS problem: <ul style="list-style-type: none"> DP slave errors No master-slave connection PROFIBUS cable not connected or not detected
 flashing red				System fault: <ul style="list-style-type: none"> CM has not received an address from the CPU Power supply of the CM was interrupted CPU reset to factory defaults Solution when the error is permanent: Station power → OFF → ON Other possible problems: <ul style="list-style-type: none"> Module fault Incomplete firmware version Contact the hotline.

In STOP mode, configuring and performing diagnostics on the CM remain possible.

2.3 Electrical connections

Power supply

The 3-pin socket for the external 24 V DC power supply is located on the top of the module. The matching plug ships with the product.

You will find the pin assignment of the socket in section Pin assignment of the socket for the external power supply (Page 25).

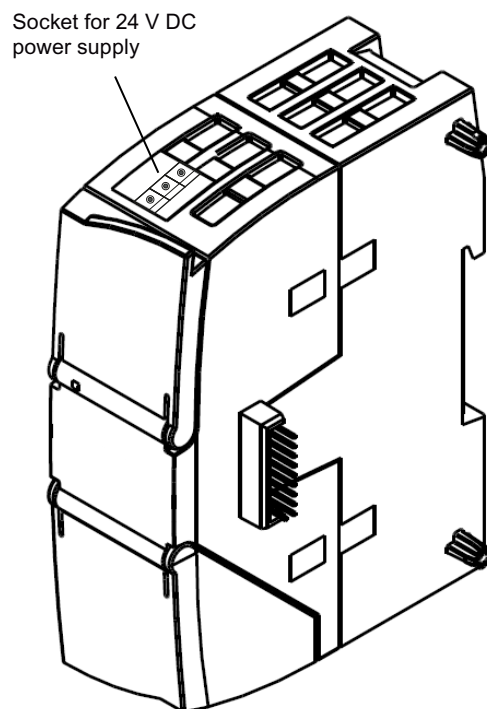

Figure 2-2 Socket for the 24 V DC power supply

9-pin D-sub female connector (PROFIBUS)

The PROFIBUS connector is located behind the lower cover of the module. The interface is a 9-pin D-sub female connector operating according to the RS-485 standard.

You also have the option of connecting to optical PROFIBUS networks via an Optical Bus Terminal OBT or an Optical Link Module OLM.

You will find the pin assignment of the D-sub socket in section Pinout of the D-sub socket (Page 26).

More detailed information on the electrical connections

For technical information on the electrical connections, refer to the section Technical specifications (Page 31).

Installing, connecting up and commissioning

Safety notices on the use of the device

The following safety notices must be adhered to when setting up and operating the device and during all work relating to it such as installation, connecting up, replacing devices or opening the device.

General notices

 WARNING
<p>Safety extra low voltage</p> <p>The equipment is designed for operation with Safety Extra-Low Voltage (SELV) by a Limited Power Source (LPS). (This does not apply to 100 V...240 V devices.)</p> <p>This means that only SELV / LPS complying with IEC 60950-1 / EN 60950-1 / VDE 0805-1 must be connected to the power supply terminals. The power supply unit for the equipment power supply must comply with NEC Class 2, as described by the National Electrical Code (r) (ANSI / NFPA 70).</p> <p>There is an additional requirement if devices are operated with a redundant power supply:</p> <p>If the equipment is connected to a redundant power supply (two separate power supplies), both must meet these requirements.</p>

 WARNING
<p>Opening the device</p> <p>DO NOT OPEN WHEN ENERGIZED.</p>

General notices on use in hazardous areas

 WARNING
<p>Risk of explosion when connecting or disconnecting the device</p> <p>EXPLOSION HAZARD</p> <p>DO NOT CONNECT OR DISCONNECT EQUIPMENT WHEN A FLAMMABLE OR COMBUSTIBLE ATMOSPHERE IS PRESENT.</p>

 **WARNING**

Replacing components

EXPLOSION HAZARD

SUBSTITUTION OF COMPONENTS MAY IMPAIR SUITABILITY FOR CLASS I, DIVISION 2 OR ZONE 2.

 **WARNING**

Requirements for the cabinet/enclosure

When used in hazardous environments corresponding to Class I, Division 2 or Class I, Zone 2, the device must be installed in a cabinet or a suitable enclosure.

General notices on use in hazardous areas according to ATEX

 **WARNING**

Requirements for the cabinet/enclosure

To comply with EU Directive 94/9 (ATEX95), this enclosure must meet the requirements of at least IP54 in compliance with EN 60529.

 **WARNING**

Suitable cables for temperatures in excess of 70 °C

If the cable or conduit entry point exceeds 70 °C or the branching point of conductors exceeds 80 °C, special precautions must be taken. If the equipment is operated in an air ambient in excess of 50 °C, only use cables with admitted maximum operating temperature of at least 80 °C.

 **WARNING**

Protection against transient voltage surges

Provisions shall be made to prevent the rated voltage from being exceeded by transient voltage surges of more than 40%. This criterion is fulfilled, if supplies are derived from SELV (Safety Extra-Low Voltage) only.

3.1 Warning overvoltage protection

CAUTION
Protection of the external 24 VDC power supply
If power is supplied to the module over longer 24 V power cables or networks, the coupling in of strong electromagnetic pulses onto the power supply cables is possible. This can be caused, for example by lightning strikes or switching of higher loads.
The connector of the external 24 VDC power supply is not protected from strong electromagnetic pulses. To protect it, an external overvoltage protection module is necessary. A suitable device is, for example, the Dehn Blitzductor BVT AD 24V type no. 918 402 or comparable protective element.
Manufacturer: DEHN + SÖHNE GmbH + Co. KG, Hans-Dehn-Str. 1, PO box 1640, D-92306 Neumarkt

3.2 Installing and commissioning the CM 1243-5

Prior to installation and commissioning

 WARNING
Read the system manual "S7-1200 Programmable Controller"
Prior to installation, connecting up and commissioning, read the relevant sections in the system manual "S7-1200 Programmable Controller" (refer to the documentation in the Appendix).
When installing and connecting up, keep to the procedures described in the system manual "S7-1200 Programmable Controller".
Make sure that the power supply is turned off when installing/uninstalling the devices.

Configuration

One requirement for the commissioning of the CP is the completeness of the STEP 7 project data. You should also read the section "Configuration and programming (Page 27)".

Dimensions for installation

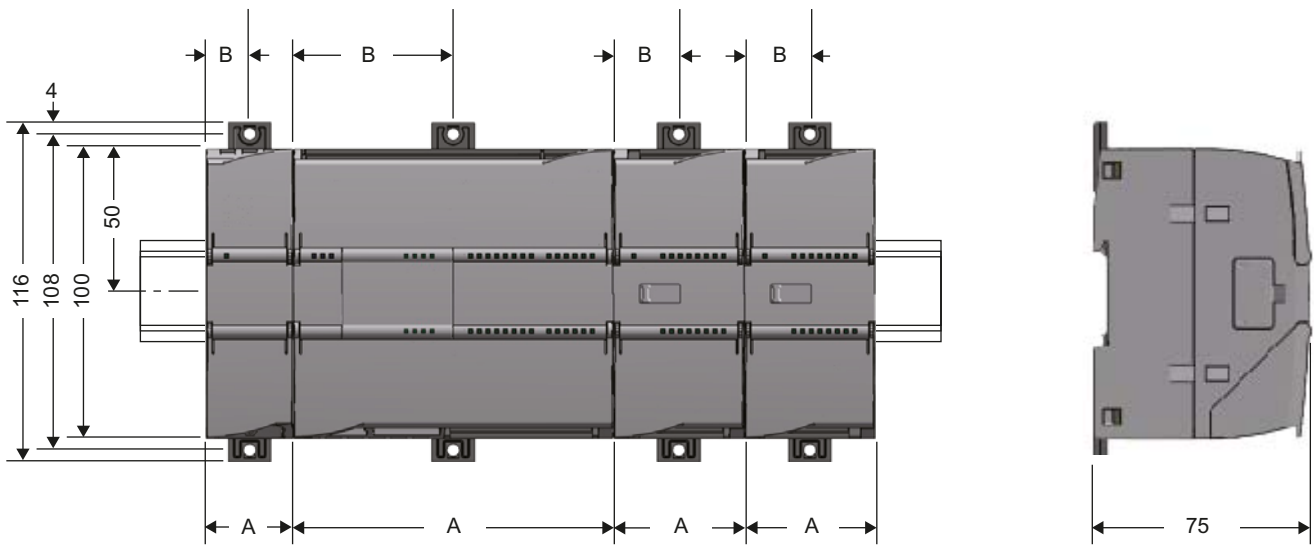

Figure 3-1 Dimensions for installation of the S7-1200

Table 3- 1 Dimensions for installation

S7-1200 devices		Width A	Width B *
CPU	CPU 1211C, CPU 1212C	90 mm	45 mm
	CPU 1214C	110 mm	55 mm
Signal modules	8 or 16 digital I/Os 2, 4 or 8 analog I/Os Thermocouple, 4 or 8 I/Os RTD, 4 I/Os	45 mm	22.5 mm
	16 analog I/Os RTD, 8 I/Os	70 mm	35 mm
Communications interfaces	CM 1241 RS-232 and CM 1241 RS-485	30 mm	15 mm
	CM 1243-5 (PROFIBUS master) CM 1242-5 (PROFIBUS slave)	30 mm	15 mm
	CP 1242-7 (GPRS CP)	30 mm	15 mm

* Width B: The distance between the edge of the housing and the center of the hole in the DIN rail mounting clip

DIN rail mounting clips

All CPUs, SMs, CMs and CPs can be installed on the DIN rail in the cabinet. Use the pull-out DIN rail mounting clips to secure the device to the rail. These mounting clips also lock into place when they are extended to allow the device to be installed in a switching panel. The inner dimension of the hole for the DIN rail mounting clips is 4.3 mm.

Procedure for installation and commissioning

NOTICE
<p>Installation location</p> <p>During installation, make sure that the upper and lower ventilation slits of the module are not obstructed and good ventilation is possible. Above and below the device, there must be a clearance of 25 mm to allow air to circulate and prevent overheating.</p> <p>Remember that the permitted temperature ranges depend on the position of the installed device.</p>

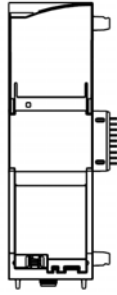
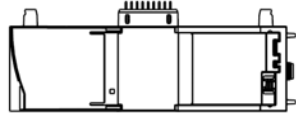
Device position / permitted temperature range	Installation location
<p>Horizontal installation of the rack: 0 °C to 55 °C</p>	
<p>Vertical installation of the rack: 0 °C to 45 °C</p>	

NOTICE
<p>Connection with power off</p> <p>Only wire up the S7-1200 with the power turned off.</p> <p>Power supply from the power outputs of the CPU</p> <p>The power of the CM must be supplied via the power outputs of the CPU.</p> <p>Keep within the maximum load of the power outputs of the CPU.</p> <p>You will find data relating to the current consumption and power loss of the CM in the section Technical specifications (Page 31).</p> <p>Grounding the PROFIBUS cable</p> <p>If a CM 1243-5 is plugged into the S7-1200, a PROFIBUS cable must always be connected to the CM 1243-5. The PROFIBUS cable must be grounded.</p>

Table 3- 2 Procedure for installation and connecting up

Step	Execution	Notes and explanations
1	Mount the CM on the DIN rail and connect it to the module to its right.	Use a 35 mm DIN rail. The slots to the left of the CPU are permitted.
2	Secure the DIN rail.	
3	Secure the power supply wires to the power output of the CPU.	
4	Secure the wires of the power supply to the plug supplied with the CM and insert the plug in the socket on the top of the CM.	The pinning is shown beside the socket on the top of the housing. You will also find this in the section Pin assignment of the socket for the external power supply (Page 25).
5	Connect the PROFIBUS cable to the D-sub female connector of the CM.	Lower surface of the CM
6	Turn on the power supply.	
7	Close the front covers of the module and keep them closed during operation.	
8	The remaining steps in commissioning involve downloading the STEP 7 project data.	The STEP 7 project data of the CM is transferred when you download to the station. To load the station, connect the engineering station on which the project data is located to the Ethernet interface of the CPU. You will find more detailed information on loading in the following sections of the STEP 7 online help: <ul style="list-style-type: none"> • "Loading project data" • "Using online and diagnostics functions"

3.3 Pin assignment of the socket for the external power supply

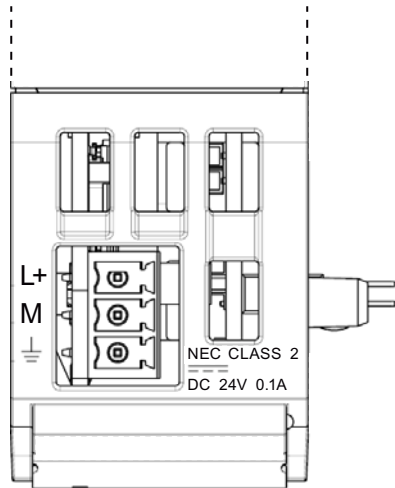



Figure 3-2 Socket for the external 24 VDC power supply (view from above)

Table 3- 3 Pin assignment of the socket for the external power supply

Pin	Labeling	Function
1	L+	+ 24 VDC
2	M	Ground reference for + 24 VDC
3		Ground connector

3.4 Pinout of the D-sub socket

PROFIBUS interface

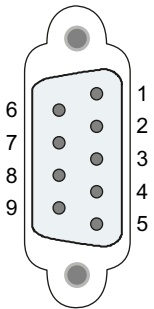

Table 3- 4 Pinout of the D-sub socket

Pin	Description	Pin	Description
1	- not used -	6	VP: Power supply +5 V only for bus terminating resistors; not for supplying external devices
2	- not used -	7	- not used -
3	RxD/TxD-P: Data line B	8	RxD/TxD-N: Data line A
4	CNTR-P: RTS	9	- not used -
5	DGND: Ground for data signals and VP	Housing	Ground connector

PROFIBUS cable and connector

CAUTION
<p>Contacting the shield of the PROFIBUS cable</p> <p>The shield of the PROFIBUS cable must be contacted.</p> <p>To do this, strip the insulation from the end of the PROFIBUS cable and connect the shield to functional earth.</p>
NOTICE
<p>If you use a 180° PROFIBUS or a PG connector, the lower panel cannot be completely closed.</p>

Configuration and programming

4.1 Configuration

Configuration in STEP 7

You configure the DP modules and DP master systems in SIMATIC STEP 7. You will find the required version in the section Requirements for operation (Page 10).

You will find the number of CMs/CPs that can be configured per station in the section Performance data (Page 9).

Overview of the STEP 7 configuration

Follow the steps below when configuring:

1. Create a STEP 7 project.
2. Insert the required SIMATIC stations.
3. Insert the communications modules and other required modules in the stations.
4. Select the PROFIBUS interface of the master module and create a DP master system using the shortcut menu (right mouse button).
5. Configure the DP master system in the following parameter groups:
 - General
 - Network settings
 - Cable configuration
 - Additional network nodes
 - Bus parameters
6. Network the PROFIBUS slaves with the master system:
 - Either using the shortcut menu command with the PROFIBUS interface selected
 - Or in the "Operating mode" parameter group of the slave module
7. Configure the slave modules.

Configuring the DP slaves is described in the manual of the slave module.
8. Configure the PROFIBUS master module.

This affects the properties in the following parameter groups:

 - General
 - PROFIBUS interface with the lower-level parameter groups "General" and "PROFIBUS address". The "Mode" of the DP master is preset.
9. Configure the remaining modules and submodules according to your requirements.
10. Save the project.

Note

You will find more detailed information on configuring the individual parameters in the help system of STEP 7.

Downloading project data

When you load the station, the project data of the CM is stored on the CPU.

4.2 Programming

DP data exchange with the CPU

No instructions are necessary for GP data exchange with the CPU. The cyclically transferred slave data is written to the input and output areas of the CPU.

Reading and writing consistent data of a standard slave

With the DPRD_DAT and DPWR_DAT instructions, you can read consistent data with a length of > 4 bytes from a slave or transfer consistent data to a slave.

Receiving interrupts with RALRM

The RALRM instruction is used to receive interrupts from DP slaves and the corresponding information is indicated by the output parameters of the instruction.

Reading and writing a data record with the RDREC and WRREC instructions

The "RDREC" and "WRREC" instructions are available for transferring configuration, diagnostics or I/O data.

S7 communication: Data exchange with remote communications partners

The CM can communicate with remote partners via PROFIBUS. The following instructions are used:

- PUT: Instruction for writing data to a remote CPU or a remote PC
- GET: Instruction for reading data from a remote CPU or a remote PC

Remote communications partners can be S7-CPU's, PC's, PG's, TD's/OP's or SCADA systems, such as WinCC.

Note

Information on the instructions

You will find information on the instructions mentioned above in the STEP 7 help.

Operating the module

5.1 Note on operation

CAUTION
Closing the front panels
To ensure interference-free operation, keep the front panels of the module closed during operation.

5.2 Diagnostics

Diagnostics options

You have the following diagnostics options available for the module:

- The LEDs of the module
 - For information on the LED displays, refer to the section LEDs (Page 14).
- STEP 7: The "Diagnostics" tab in the Inspector window
 - Here, you can obtain the following information on the selected module:
 - Entries in the diagnostics buffer of the CPU
 - Information on the online status of the module
- STEP 7: Diagnostics functions in the "Online > Online and diagnostics" menu
 - Here, you can obtain static information on the selected module:
 - General information on the module
 - Diagnostics status
 - Information about the PROFIBUS interface:
 - Settings
 - Statistics
 - Node list with PROFIBUS address and response on PROFIBUS

You can obtain further information on the diagnostics functions of STEP 7 in the STEP 7 online help.

- DP diagnostics

You will find the description of the functions of DP diagnostics in the documentation of the relevant slave (for example, in the manual of the CM 1242-5, see /3/ (Page 42)).

The evaluation of diagnostics data records requested by the DP master and the diagnostics interrupts or diagnostics alarms of the DP slaves is handled in the user program of the DP master station.

5.3 Downloading firmware

New firmware versions

If a new firmware version is available for the module, you will find this on the Ethernet pages of the Siemens Automation Customer Support under the following ID:

44632196 (<http://support.automation.siemens.com/WW/view/en/44632196>)

On the Internet page, select the "Entry list" tab and the "Download" entry type. You will find the firmware file and a description of the procedure there.

You can recognize that firmware is being loaded by the flashing LEDs of the CM, see section LEDs (Page 14).

5.4 Module replacement

Module replacement

The configuration data of the CM is stored on the local CPU. This allows simple replacement of this communications module when necessary.

When the station starts up again, the new CM reads the project data from the CPU.

WARNING

Read the system manual "S7-1200 Programmable Controller"

Prior to installation, connecting up and commissioning, read the relevant sections in the system manual "S7-1200 Programmable Controller" (refer to the documentation in the Appendix).

When installing and connecting up, keep to the procedures described in the system manual "S7-1200 Programmable Controller".

Make sure that the power supply is turned off when installing/uninstalling the devices

Technical specifications

Table 6- 1 Technical specifications of the CM 1243-5

Technical specifications	
Order number	6GK7 243-5DX30-0XE0
Interfaces	
Connection to PROFIBUS	9-pin D-sub female connector
Maximum current consumption on the PROFIBUS interface when connecting network components (for example optical network components)	15 mA at 5 V (only for bus termination) *)
Permitted ambient conditions	
Ambient temperature	
• During storage	• -40 °C to 70 °C
• During transportation	• -40 °C to 70 °C
• During operation with the rack installed horizontally	• 0 °C to 55 °C
• During operation with the rack installed vertically	• 0 °C to 45 °C
Relative humidity at 25 °C during operation, without condensation, maximum	95 %
Degree of protection	IP20
Power supply, current consumption and power loss	
Type of power supply	DC
Power supply / external	24 V
• minimum	• 19.2 V
• maximum	• 28.8 V
Current consumption (typical)	
• from 24 V DC	• 100 mA
• from the S7-1200 backplane bus	• 0 mA
Effective power loss (typical)	
• from 24 V DC	• 2.4 W
• from the S7-1200 backplane bus	• 0 W
Power supply 24 VDC / external	
• Min. cable cross section	• min.: 0.14 mm ² (AWG 25)
• Max. cable cross section	• max.: 1.5 mm ² (AWG 15)
• Tightening torque of the screw terminals	• 0.45 Nm (4 lb-in)
Electrical isolation	710 VDC for 1 minute
• PROFIBUS interface to ground	
• PROFIBUS interface to internal circuit	

Technical specifications

Dimensions and weights

- | | |
|----------|----------|
| • Width | • 30 mm |
| • Height | • 100 mm |
| • Depth | • 75 mm |
-

Weight

- | | |
|------------------------------|---------|
| • Net weight | • 134 g |
| • Weight including packaging | • 171 g |
-

*)The current load of an external consumer connected between VP (pin 6) and DGND (pin 5) must not exceed a maximum of 15 mA (short-circuit proof) for bus termination.

Dimension drawings

A

Note

All dimensions in the drawings are in millimeters.

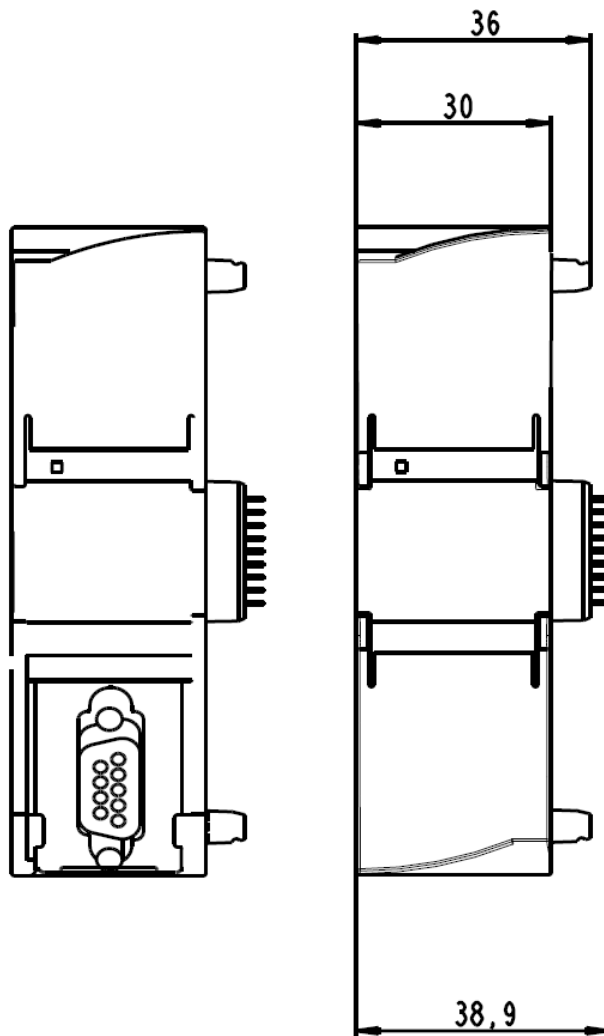

Figure A-1 CM 1243-5 - front view

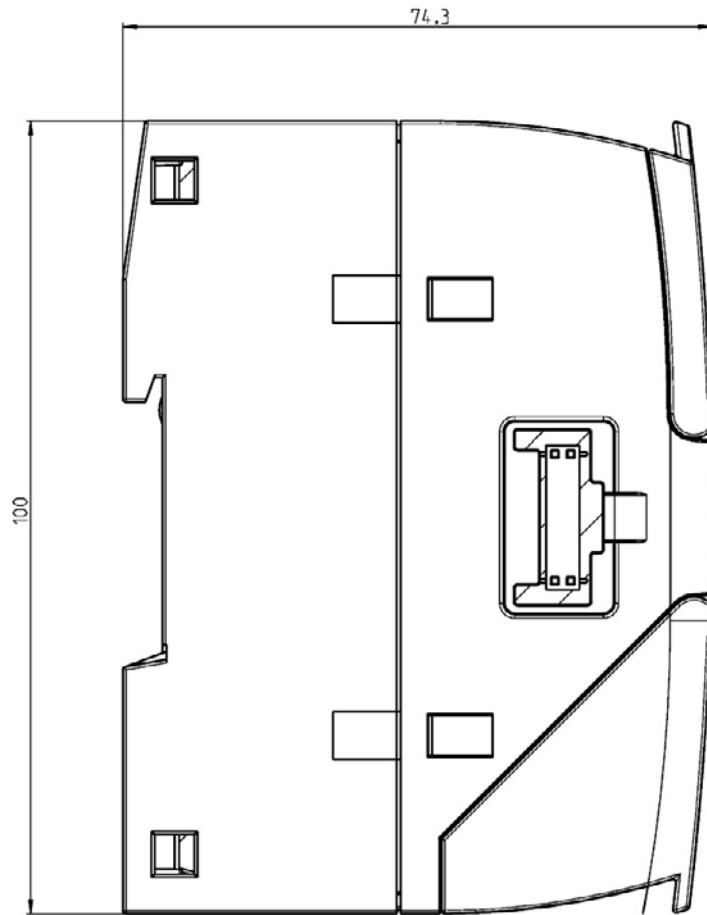

Figure A-2 CM 1243-5 - left side view

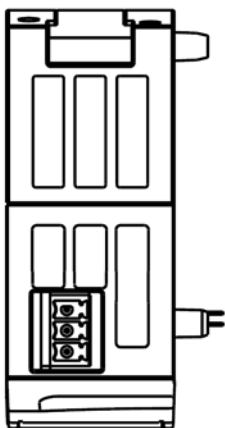

Figure A-3 CM 1243-5 - view from above

Approvals

Approvals issued

NOTICE
Issued approvals on the type plate of the device
The specified approvals apply only when the corresponding mark is printed on the product. You can check which of the following approvals have been granted for your product by the markings on the type plate.
Approvals for shipbuilding are not printed on the device type plate.

Current approvals on the Internet

SIMATIC NET products are regularly submitted to the relevant authorities and approval centers for approvals relating to specific markets and applications.

You will also find the current approvals for the product on the Internet pages of Siemens Automation Customer Support under the following entry ID:

(<http://support.automation.siemens.com/WW/view/en/44632657>)

→ "Entry list" tab, entry type "Certificates"

Approvals for SIMATIC NET products

You will find an overview of the approvals for SIMATIC NET products including approvals for shipbuilding on the Internet pages of Siemens Automation Customer Support under the following entry ID:

57337426 (<http://support.automation.siemens.com/WW/view/en/57337426>)

Overview of the approvals

The CM 1243-5 has the following approvals:

- cULus LISTED IND. CONT. EQ. for HAZ.LOC.
cULus LISTED IND. CONT. EQ.
- FM
- ATEX: KEMA 10 ATEX 0166X

- C-TICK
- EC declaration of conformity
 - EC Directive 2004/108/EEC "Electromagnetic Compatibility" (EMC Directive)
 - EC Directive 2002/95/EC (RoHS)
 - Use in industrial environments according to:
 - EN 61000-6-4:2007
 - EN 61000-6-2:2005

Standards and test specifications

The product meets the following standards and test specifications. The test criteria for the module are based on these standards and test specifications.

EC declaration of conformity



The product meets the requirements and safety objectives of the following EC directives and it complies with the harmonized European standards (EN) for programmable logic controllers which are published in the official documentation of the European Union.

- EC directive 2006/95/EEC "Electrical Equipment Designed for Use within Certain Voltage Limits" (Low Voltage Equipment Directive)
 - EN 61131-2:2007 Programmable controllers - Equipment requirements and tests
- EC Directive 2004/108/EEC "Electromagnetic Compatibility" (EMC Directive)
 - Emission
EN 61000-6-4:2007: Industrial area
 - Immunity
EN 61000-6-2:2005: Industrial area
- EC directive 94/9/EC "Equipment and protective systems intended for use in potentially explosive atmospheres" (ATEX Explosion Protection Directive)
 - EN 60079-15:2005: Type of protection 'n':

The EC Declaration of Conformity is available for all responsible authorities at:

Siemens Aktiengesellschaft
Industry Automation
Industrielle Kommunikation SIMATIC NET
Postfach 4848
D-90327 Nürnberg
Germany

You will find the EC Declaration of Conformity for this product on the Internet at the following address:

10805878 (<http://support.automation.siemens.com/WW/view/en/10805878>) → Tab "Entry List"

Filter settings:
 Entry type: "Certificates"
 Certificate Type: "Declaration of Conformity"
 Search items(s): <name of the module>

cULus approval



Underwriters Laboratories Inc. meets

- Underwriters Laboratories, Inc.: UL 508 Listed (industrial control devices)
- Canadian Standards Association: CSA C22.2 Number 142 (process control equipment)

FM certification



Factory Mutual Research (FM):

Certification standard class number 3600 and 3611

Approved for use in:

Class I, Division 2, Gas Group A, B, C, D, Temperature Class T4A,
 Ta = 55 °C

Class I, Zone 2, IIC, Temperature Class T4, Ta = 55 °C

ATEX approval



EN 60079-0:2006: Potentially explosive atmosphere - general requirements

EN 60079-15:2005: Electrical apparatus for explosive gas atmospheres;

Type of protection 'n'

II 3 G Ex nA II T4

Over and above this, the following conditions must be met for the safe deployment of the product:

- Install the modules in a suitable enclosure with degree of protection of at least IP54 to EN 60529 and take into account the environmental conditions for operation of the devices.
- If the rated temperatures of 70°C at the cable entry or 80°C at the branching point of the wires are exceeded, the permitted temperature range of the selected cable must be suitable for the actual measured temperatures.
- Measures must be taken to prevent the rated voltage being exceeded by more than 40% due to transient disturbances.

C-Tick approval



The product meets the requirements of the AS/NZS 2064 standards (Class A)

Maritime approvals

The S7-1200 products are regularly submitted to the relevant authorities for approvals relating to specific markets and applications. If you require a list of the current approvals for individual devices, consult your Siemens contact.

Standards and test specifications

The device meets the following standards and test specifications. The test criteria for the device are based on these standards and test specifications.

Industrial environments

The product was developed for use in industrial environments.

Application	Requirements for emissions	Requirements for immunity
Industry	EN 61000-6-4:2007	EN 61000-6-2:2005

Electromagnetic compatibility (EMC)

The electromagnetic compatibility (EMC) of an electrical device is its capability of functioning as intended in an electromagnetic environment without emitting electromagnetic interference that could impair the operation of other electrical devices in the vicinity.

Electromagnetic compatibility - immunity	
EN 61000-4-2 Electrostatic discharge	8 kV air discharge to all surfaces 4 contact discharge to exposed conductive surfaces
EN 61000-4-3 Radiated electromagnetic field	80 to 1 000 MHz, 10 V/m, 80% AM at 1 kHz 1.4 to 2.0 GHz, 3 V/m, 80% AM at 1 kHz 2.0 to 2.7 GHz, 1 V/m, 80% AM at 1 kHz
EN 61000-4-4 Fast transient bursts	2 kV, 5 kHz with coupling network to AC and DC system power 1 kV, 5 kHz with coupling clamp to inputs/outputs
EN 61000-4-5 Surge immunity	DC systems - 2 kV common mode, 1 kV push-pull For DC systems (I/O signals, DC power supplies), external protection is necessary. 2 kV via coupling clamp on PROFIBUS cable
EN 61000-4-6 Conducted disturbances	150 kHz to 80 MHz, 10 V RMS, 80 % AM at 1 kHz
EN 61000-4-611 Voltage dips	DC systems 0 % for 1 cycle, 40 % for 12 cycles and 70 % for 30 cycles at 60 Hz

Electromagnetic compatibility - emission	
Conducted emissions EN 61000-6-4, class A 0.15 MHz to 5 MHz 5 MHz to 30 MHz	< 79 dB (µV) quasi peak; <66 dB (µV) average < 73 dB (µV) quasi peak; <60 dB (µV) average
Conducted emissions EN 61000-6-4, class A 30 MHz to 230 MHz 230 MHz to 1 GHz	< 40 dB (µV/m) quasi peak; measured at 10 m < 47 dB (µV/m) quasi peak; measured at a distance of 10 m

Environmental conditions

Environmental conditions - transportation and storage	
EN 60068-2-2, Test Bb, dry heat and EN 60068-2-1 Test Ab, cold	-40 °C to +70 °C
EN 60068-2-30, Test Db, damp heat	25 °C to 55 °C, 95% humidity
EN 60068-2-14, Test Na, temperature shock	-40 °C to +70 °C, dwell time 3 hours, 2 cycles
EN 60068-2-32 Free fall	0.3 m, five times, in product packaging
Atmospheric pressure	1 080 to 660 hPa (corresponding to an altitude of -1 000 to 3 500 m)

Environmental conditions - operation	
Ambient temperatures / air humidity (inlet air 25 mm below device)	0 °C to 55 °C for horizontal installation of the rack 0 °C to 45 °C for vertical installation of the rack 95% relative humidity, non-condensing
Atmospheric pressure	1080 to 795 hPa (corresponding to an altitude of -1000 to 2000 m)
EN 60068-2-14, Test Nb, temperature change	5 °C to 55 °C, 3 °C/minute
EN 60068-2-27 Mechanical shock	15 g, 11 ms pulse, 3 positive and 3 negative shocks in each of the 3 axes (half sine)
EN 60068-2-6 Sinusoidal vibration (DIN rail mount)	2 mm PP from 2 to 13 Hz and 0.7 g from 13 to 100 Hz (according to shipbuilding 1); 10 sweeps per axis, 1 octave/minute

Protection class

- Protection class III according to EN 61131-2 (protective conductor not required)

Degree of protection

- Mechanical protection to EN 60529: IP20

Protects against finger contact with high voltage as tested by standard probe. External protection required for dust, dirt, water and foreign objects of < 12.5 mm in diameter.

References

Where to find Siemens documentation

- You will find the order numbers for the Siemens products of relevance here in the following catalogs:
 - SIMATIC NET Industrial Communication / Industrial Identification, catalog IK PI
 - SIMATIC Products for Totally Integrated Automation and Micro Automation, catalog ST 70

You can request the catalogs and additional information from your Siemens representative.

- You will find SIMATIC NET manuals on the Internet pages of Siemens Automation Customer Support:

Link to Customer Support (<http://support.automation.siemens.com/WW/view/en>)

Enter the entry ID of the relevant manual as the search item. The ID is listed below some of the reference entries in brackets.

As an alternative, you will find the SIMATIC NET documentation on the pages of Product Support:

10805878 (<http://support.automation.siemens.com/WW/view/en/10805878>)

Go to the required product group and make the following settings:

→ Entry list → Entry type "Manuals / Operating Instructions"

You will find the documentation for the SIMATIC NET products relevant here on the data medium that ships with the product:

- Product CD / product DVD or
- SIMATIC NET Manual Collection

/1/

SIMATIC
S7-1200 Programmable Controller
System Manual
Siemens AG
order number: 6ES7298-8FA30-8BH0
Entry ID: 36932465 (<http://support.automation.siemens.com/WW/view/en/36932465>)

0 /2/

/2/

SIMATIC NET
PROFIBUS Network Manual
system manual
Siemens AG
Entry ID: 35222591 (<http://support.automation.siemens.com/WW/view/en/35222591>)

/3/

SIMATIC NET
CM 1242-5
Operating Instructions
Siemens AG
entry ID: 49852105 (<http://support.automation.siemens.com/WW/view/en/49852105>)

Training, Service & Support

Online support

In addition to our product documentation, the comprehensive online information platform supports you in all aspects of our Service & Support at any time and from any location in the world. You will find this on the Internet at the following address:

<http://support.automation.siemens.com/WW/llisapi.dll?func=cslib.csinfo2&aktprim=99&lang=en>

Here, you will find the following information:

- Support news, newsletter
- Product information, Product Support, Applications & Tools
- Technical Forum
- Access to other features of our Service & Support offer:
 - Technical Consulting
 - Engineering Support
 - Field Service

Phone: +49 (0)911 895 7444

- Spare parts and repairs

Phone: +49 (0)911 895 7448

- Optimization and modernization
- Technical Support

Expert advice on technical questions with a wide range of demand-optimized services for all our products and systems.

Phone: +49 (0)911 895 7222

<https://support.automation.siemens.com/WW/llisapi.dll?func=cslib.csinfo&lang=en&objid=38718979&caller=view>

You will find contact data on the Internet at the following address:

www.automation.siemens.com/partner

SITRAIN - Siemens training for automation and industrial solutions

With over 300 different courses, SITRAIN covers the entire Siemens product and system spectrum in the field of automation and drive technology. Advanced training tailored to your needs is also available. In addition to our classic range of courses, we also offer a combination of various training media and sequences. You can, for example, use self-study programs on CD-ROM or on the Internet as preparation or to consolidate training.

You will find detailed information on our training curriculum and how to contact our customer consultants at the following Internet address:

www.siemens.com/sitrain

Glossary

Bus parameter

Special parameters that control transfer characteristics on the bus. Each PROFIBUS node must use bus parameters that match the bus parameters of other nodes.

CLEAR mode

Mode of the DP master; inputs are read cyclically, outputs remain set to 0.

CM

Communications module

Module for communications tasks that is used in an automation system as an interface expansion of the CPU. Same interface types of a CPU and a CM are functionally identical.

Control job

Control command for DP mode.

Examples:

CLEAR, SYNC, FREEZE, UNFREEZE, ACT, DEACT.

CP

Communications processor

Module for expanded communications tasks that provides the CPU with additional interface types or communications options.

DP I/O module

Component of a DP slave. DP slaves have a modular structure. A DP slave has at least one DP I/O module.

DP master

A node with master functionality on PROFIBUS DP. The following must be distinguished:

DP master (class 1) or DP master 1

The DP master 1 handles cyclic user data traffic with the DP slaves assigned to it.

DP master (class 2) or DP master 2

The DP master 2 provides asynchronous services such as :

- Reading input/output data
- Diagnostics

DP master system

A DP master and all DP slaves with which this DP master exchanges data.

DP mode

Communication between the DP master and DP slaves can be divided into four modes: OFFLINE, STOP, CLEAR, RUN (corresponds to OPERATE according to the DP standard)

Each of these modes is characterized by defined actions between the DP master and the DP slaves.

DP module name

Name of one of the DP I/O modules entered in the DP module list.

DP module type

Name to identify a DP I/O module in the generic station data of a DP slave in compliance with EN 50170, Vol 2.

DP protocol

The rules for communication and data transmission according to the communications standard for the field area (IEC 61158) and PROFIBUS standard (EN 50170).

Note:

The DP protocol is used in the distributed peripheral I/O (DP) and allows distributed use of numerous modules and other field devices in the immediate vicinity of the process.

DP slave

A node with slave functionality on PROFIBUS DP

DP slave name

To identify a DP slave in the configured DP configuration, a DP slave name is entered in the DP slave list.

DP subnet

PROFIBUS subnet on which only distributed I/O is operated.

FREEZE mode

The FREEZE mode is a DP mode in which process input data is obtained at the same time from one or more (group) or from all DP slaves. The time of acquisition is signaled by the FREEZE command (this is a control frame for synchronization).

Group identification

Allows the assignment of DP slaves to one or more groups. The DP slaves can be addressed specifically when transferring control frames using the group identification.

SYNC mode

A DP mode in which one, several (group) or all DP slaves transfer data to their process outputs at a certain time. The time at which the data is transferred is indicated in the SYNC command (a control command for synchronization).

UNFREEZE

Job for resetting the FREEZE mode.

UNSYNC

Job for resetting the SYNC mode.

Watchdog time

A monitoring time that can be set on a DP slave to detect failure of the controlling DP master.

Index

A

ATEX, 20
ATEX approval, 37

C

Configuration limits, 9
CPU firmware version, 10

D

Degree of protection, 39
Dimensions, 22, 32
Downloading project data, 24, 28

E

Electromagnetic compatibility (EMC), 38
EMC, 38
Environment, industry, 38
Environmental conditions, 39

F

Firmware version, 3
Firmware, version, 11

H

Hardware product version, 3
Hazardous area, 19

O

Operating states, 15

P

PROFINET IO devices, 9
Protection class, 39

R

Replacing a module, 30
Resources, 9

S

Safety notices, 19
STEP 7 version, 10
SYNC / FREEZE, 8

