

SIMATIC NET PROFIBUS

Optical Link Module

OLM / P11 V4.0

OLM / P12 V4.0

OLM / P22 V4.0

OLM / P11 V4.0

OLM / G12 V4.0

OLM / G22 V4.0

OLM / G12-EEC V4.0

Operating Instructions

<u>Preface</u>	1
<u>Introduction</u>	2
<u>Network Topologies</u>	3
<u>Product Characteristics</u>	4
<u>Installation and Maintenance</u>	5
<u>Approvals and Marks</u>	6
<u>References</u>	7
<u>Drawings</u>	8

Safety Guidelines

These operating instructions contain notices which you should observe to ensure your own personal safety as well as to avoid property damage. The notices referring to your personal safety are highlighted in the manual by a safety alert symbol, notices referring to property damage only have no safety alert symbol. Depending on the danger level, the notices are displayed in descending order as follows.



Danger

indicates that death or severe personal injury **will** result if proper precautions are not taken.



Warning

indicates that death or severe personal injury **may** result if proper precautions are not taken.



Caution

with safety alert symbol indicates that minor personal injury can result if proper precautions are not taken.

Caution

without safety alert symbol indicates that property damage can result if proper precautions are not taken.

Notice

used without the safety alert symbol indicates a potential situation which, if not avoided, may result in an undesirable result or state.

When several danger levels apply, the notices of the highest level (lower number) are always displayed. If a notice refers to personal damages with the safety alert symbol, then another notice may be added warning of property damage.

Copyright Siemens AG 2010. All rights reserved.

The reproduction, transmission or use of this document or its contents is not permitted without express written authority. Offenders will be liable for damages. All rights, including rights created by patent grant or registration of a utility or design, are reserved.

Siemens AG
Industry Sector Industry Automation Division
Industrielle Kommunikation (I IA SC IC)
Postfach 4848, D-90026 Nürnberg

Disclaimer

We have checked the contents of this manual for agreement with the hardware and software described. Since deviations cannot be precluded entirely, we cannot guarantee full agreement. However, the data in this manual are reviewed regularly and any necessary corrections included in subsequent editions.

Siemens AG 2007, 2010
Subject to technical change

Qualified Personnel

The device/system may only be set up and operated in conjunction with this documentation. Only **qualified personnel** should be allowed to install and work on the equipment. Qualified persons are defined as persons who are authorized to commission, to ground, and to tag circuits, equipment, and systems in accordance with established safety practices and standards.

Correct Usage of Hardware Products

Please note the following:



Warning

This device may only be used for the applications described in the catalog or the technical description, and only in connection with devices or components from other manufacturers which have been approved or recommended by Siemens. This product can only function correctly and safely if it is transported, stored, set up, and installed correctly, and operated and maintained as recommended.

Note: If PROFIBUS OLMs are supplied via long 24 V supply lines or over networks, measures must be taken to prevent interference by strong electro magnetic pulses on the supply lines. These can occur, for example, due to lightning strikes or when heavy inductive loads are switched. The robustness of the PROFIBUS OLM against electromagnetic interference was verified by the Surge Immunity Test according to EN61000-4-5. For this test, overvoltage protection for the voltage supply lines is necessary. The Dehn Blitzductor VT AD 24V Type no. 918402 or a comparable protection element is, for example, suitable. Manufacturer: DEHN+SÖHNE GmbH+Co.KG Hans Dehn Str.1 Postfach 1640 D-92306 Neumarkt, Germany

Brands

All names which are labeled with the trademark symbol [®] are registered trademarks of Siemens AG. Third parties using for their own purposes any other names in this document which refer to trademarks might infringe upon the rights of the trademark owners.

Contents

1	Preface	1
1.1	Preface	1
2	Introduction.....	3
2.1	Introduction	3
3	Network Topologies.....	7
3.1	Linear (bus) Topology	8
3.1.1	Linear (bus) topology with fiber-optic link monitoring and segmentation.....	9
3.1.2	Bus topology without fiber-optic link monitoring.....	9
3.2	Star Topology.....	10
3.3	Ring Topology	12
3.3.1	Redundant Optical Ring with two OLMs	14
4	Product Characteristics.....	17
4.1	Technical Specifications	17
4.2	Installation.....	20
4.2.1	Safety related notices	20
4.2.2	General information on commissioning	21
4.2.3	Setting compatibility, mode and transmit power	22
5	Installation and Maintenance	27
5.1	Installation	27
5.1.1	Installation instructions.....	27
5.1.2	Connecting optical cables	30
5.2	Installation of the Modules	31
5.3	Connection of the Electrical RS-485 Bus Cables	33
5.4	Connecting of the Operating Power Supply.....	35
5.5	Connecting the Signaling Contact Wires	35
5.6	Receive Level of the Optical Channels.....	36
5.7	LED Displays and Troubleshooting	37
5.7.1	LED displays	37
5.7.2	Troubleshooting	39
5.8	Maintenance.....	41
5.9	Cleaning	41
5.10	Configuration.....	42
5.10.1	Configuring optical bus and star topologies.....	42
5.10.2	Configuring redundant optical rings	42
6	Approvals and Marks	45
6.1	CE Mark	45
6.2	c-tick.....	46
6.3	FM approval	47

6.4	Ex approval	47
6.5	UL approval (U.S. and Canada).....	47
6.6	Shipbuilding approvals.....	48
7	References	49
7.1	References.....	49
8	Drawings.....	51

Tables

Table 2-1	Number of electrical and optical ports per module,	4
Table 4-1	Overview of the product characteristics.....	19
Table 4-2	DIL-switches in compatibility mode.....	23
Table 5-1	Meaning of the LED displays and indication by the signaling contact.....	39
Table 5-2	Constants for calculating the slot time for DP-standard (redundant optical ring)	43
Table 5-3	Constants for calculating the slot time for DP/FMS ("universal") and DP with S5 95U (redundant optical ring).....	43

Figures

Figure 2-1	PROFIBUS OLM with position of all interfaces, displays and adjustment options	3
Figure 3-1	Network structure in a linear (bus) optical topology.....	8
Figure 3-2	Network structure with an optical star topology	10
Figure 3-3	Network structure with a redundant optical ring topology.....	12
Figure 4-1	View of the OLM module from the top	21
Figure 4-2	Minimum cable length for use of plastic fiber S 980/1000 without fixed attenuator.....	26
Figure 5-1	Measures to suppress.....	27
Figure 5-2	Securing shielded cables with cable clamps and cable retainers.....	28
Figure 5-3	View of the module from below.....	30
Figure 5-4	Installation of a module on a standard DIN rail.....	31
Figure 5-5	Installation of a module with a mounting plate.....	32
Figure 5-6	Drilling measures for the mounting plate, all dimensions are millimeter.....	33
Figure 5-7	Electrical port, connector assignment D-sub jack.....	33
Figure 5-8	Operating power supply, pin assignment 5-pin terminal block	35
Figure 5-9	Signaling contact relay with floating contacts;	35
Figure 5-10	Signaling contact, pin assignment 5 pin terminal block	35
Figure 5-11	Position of the level recording connections	36

Figure 5-12	Relationship between measured output voltage and signal quality.....	36
Figure 5-13	LED displays on the front panel.....	37

1 Preface

1.1 Preface

Purpose of the operating instructions

These operating instructions support you when commissioning PROFIBUS OLM devices (Optical Link Module)

Validity of these operating instructions

These operating instructions are valid for the following devices:

SIMATIC NET OLM / P11 V4.0	6GK1 503-2CA00
SIMATIC NET OLM / P12 V4.0	6GK1 503-3CA00
SIMATIC NET OLM / P22 V4.0	6GK1 503-4CA00
SIMATIC NET OLM / G11 V4.0	6GK1 503-2CB00
SIMATIC NET OLM / G12 V4.0	6GK1 503-3CB00
SIMATIC NET OLM / G22 V4.0	6GK1 503-4CB00
SIMATIC NET OLM / G12-EEC V4.0	6GK1 503-3CD00
SIMATIC NET OLM / G11-1300 V4.0	6GK1 503-2CC00
SIMATIC NET OLM / G12-1300 V4.0	6GK1 503-3CC00

Convention

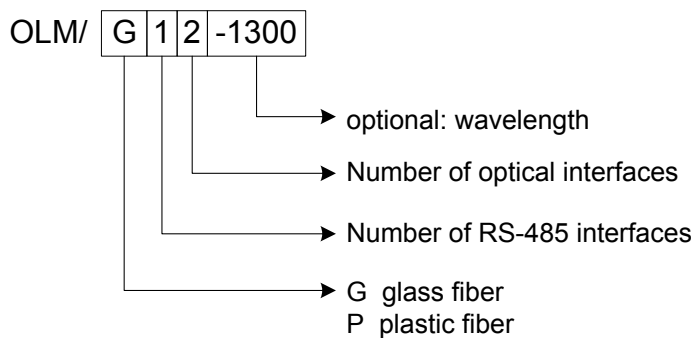

Further documentation

You will find more information on other SIMATIC NET products that you can use with the OLM V4.0 devices in the “SIMATIC NET PROFIBUS networks SIEMENS AG” manual.

Finding information

To help you find the information you require more quickly, the manual includes not only the table of contents but also the following sections in the Appendix:

- Glossary
- Index

Audience

These operating instructions are intended for persons involved in the commissioning of PROFIBUS networks with the link modules of the OLM V4.0 series.

Standards and approvals

The devices of the OLM V4.0 series meet the requirements for the CE mark. For detailed information, please refer to chapter 6 of these operating instructions.

The devices of the OLM V4.0 series also meet the requirements for the UL, C-Tick, FM and ATEX marks. For detailed information please refer to chapter 6 of these operating instructions.

The devices of the OLM V4.0 series also meet several requirements for shipbuilding. For the respectively valid approvals call our hotline +49-18050500222.

Furthermore you can gather information at:

<http://support.automation.siemens.com>

2 Introduction

2.1 Introduction

This section provides you with an overview of the functions of the PROFIBUS OLM4.0 product family.

What is possible?

PROFIBUS OLMs are designed for use in optical PROFIBUS fieldbus networks. They allow the conversion of electrical PROFIBUS interfaces (RS-485 level) into optical PROFIBUS interfaces and vice versa.

The modules can be integrated in existing PROFIBUS fieldbus networks with the known advantages of optical transmission technology. A complete PROFIBUS fieldbus network can also be set up with modules in a linear (bus), star or ring topology as well as any combination of these topologies.

To increase the reliability of the fieldbus network in case of failure, the redundant ring is supported.

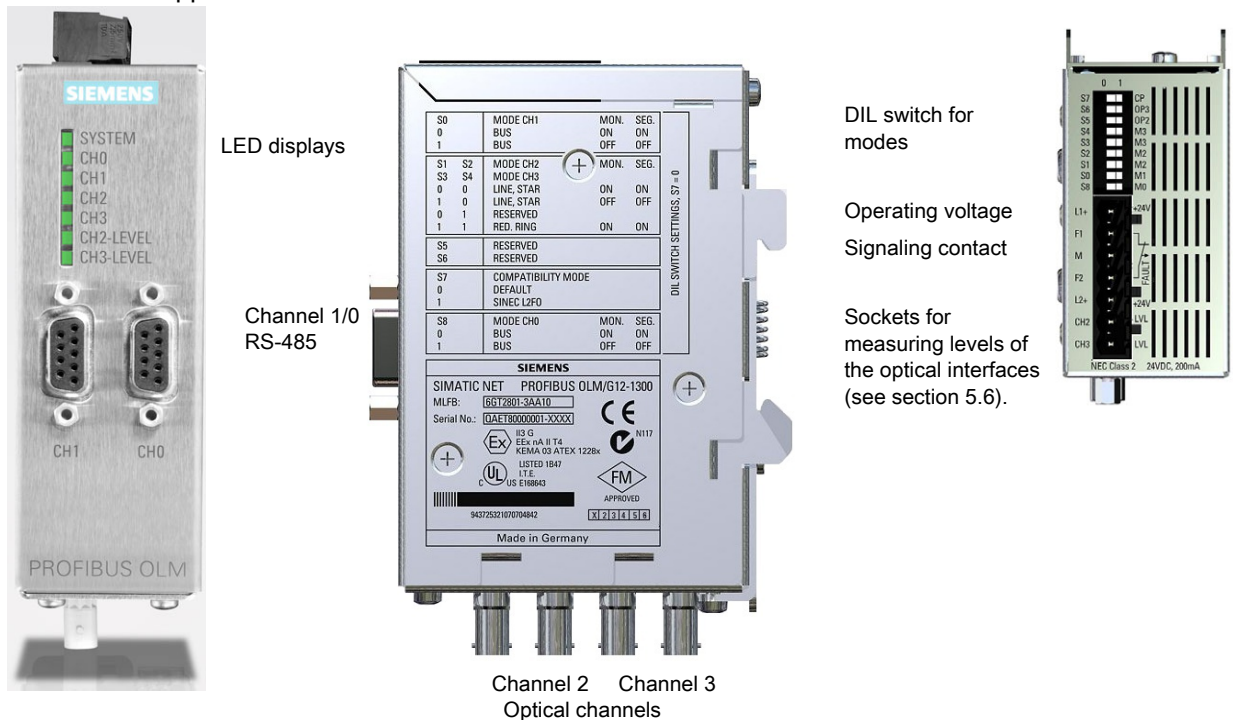

Figure 2-1 PROFIBUS OLM with position of all interfaces, displays and adjustment options

Every module has two (OLM P11, G11), three (OLM P12, G12), or four (OLM P22, G22) independent channels (ports) that consist of transmitter and receiver pairs. The power supply voltage for operation is 24 V DC. To increase operational reliability, a redundant power supply is possible.

The electrical channel is designed as 9-pin D-sub socket. An RS-485 bus segment complying with PROFIBUS standard EN 50170 /2/ can be connected to this channel. The fiber-optic cables are connected via BFOC¹/2.5 connectors. Six multicolor LEDs indicate the current mode and any disruptions as well as the level ratios on the optical interfaces.

Table 2-1 shows the different connection options of the modules and the maximum possible optical range of the single channels.

OLM/	P11	P12	P22	G11	G12 G12-EEC	G22	G11- 1300	G12- 1300
Number of channels								
-electrical	1	1	2	1	1	2	1	1
-optical	1	2	2	1	2	2	1	2
Fiber types that can be used								
- plastic fiber-optic cables 980/1000 µm	80 m	80 m	80 m	-	-	-	-	-
- PCF fiber-optic cables (HCS [®]) 200/230 µm	400 m	400 m	400 m	-	-	-	-	-
- silica glass fiber-optic cables								
10/125 µm (9/125µm)	-	-	-	-	-	-	15 km	15 km
50/125 µm	-	-	-	3 km	3 km	3 km	10 km	10 km
62.5/125 µm	-	-	-	3 km	3 km	3 km	10 km	10 km

Table 2-1 Number of electrical and optical ports per module, usable fiber types, as well as maximum achievable fiber-optic cable distances between the modules. See the "Technical Data" for precise conditions of use. PCF stands for Polymer Cladded Fiber and is similar to HCS[®] ².

There is a measurement output available for every channel, at which the optical input level can be measured with a standard voltmeter.

The various error and disruption messages of the OLM are available as a group signal via a signaling contact (relay with floating contacts) for further processing. The individual modes as well as error/fault messages are displayed by several multicolor LEDs on the front panel of the device (see section 5.7.1).

The mechanical design consists of a compact and stable metal housing which can be mounted either on a DIN rail or on a mounting plate.

The modules are configured using switches that are easily accessible from the outside.

¹ BFOC stands for Bayonet Fiber Optic Connector.

This type of connector is functionally compatible with ST connectors.

ST is a registered trademark of the company AT&T.

² HCS[®] is a trademark of Ensign-Bickford Optics Company.

The PROFIBUS OLMs comply with the standard EN 50170 /2/ and with the technical guideline “Optical transmission technology for PROFIBUS” published by the PROFIBUS User Organization (PNO).

OLM/G12 and OLM/G12-EEC have the same functions. They only differ in the specification of the ambient climatic conditions: the OLM/G12 is suitable for use in the standard temperature range from 0 °C to 60 °C, whereas the OLM/G12-EEC (extended environmental conditions) can be used in the extended temperature range of -25 °C to +60 °C and up to 100% humidity (condensing).

3 Network Topologies

Which network topologies can be implemented?

The following network topologies can be implemented with the PROFIBUS OLM:

- Point-to-point connection
- Bus (linear) topology
- Star topology
- Redundant optical ring

Combinations of these basic types are also possible. To set up the fiber-optic links of these network topologies, cables with two optical fibers are used.

If a high degree of availability is required of the fieldbus network, this can be increased by using a redundant network configuration, for example to allow continued communication if a cable is broken.

Please note the following:

- Single DTEs or complete PROFIBUS segments with a maximum of 31 nodes can be connected to the electrical interface of the PROFIBUS OLM.
- Use only fiber-optic cables in areas subject to heavy noise to avoid EMC problems affecting the entire network.
- **Only OLMs of the same wavelength** may be connected to each other optically:
 - OLM/P11, OLM/P12 and OLM / P22 with each other
 - OLM/G11, OLM/G12, OLM / G22, and OLM/G12 EEC with each other
 - OLM/G11-1300 and OLM/G12-1300 with each other
- Optical channels connected via fiber-optic cables must be set to the same mode.
- Transitions between different OLM types are only possible via the RS-485 interface.
- In the network topologies described below, the OLM/G12-EEC can be used everywhere where an OLM/G12 can be used.

3.1 Linear (bus) Topology

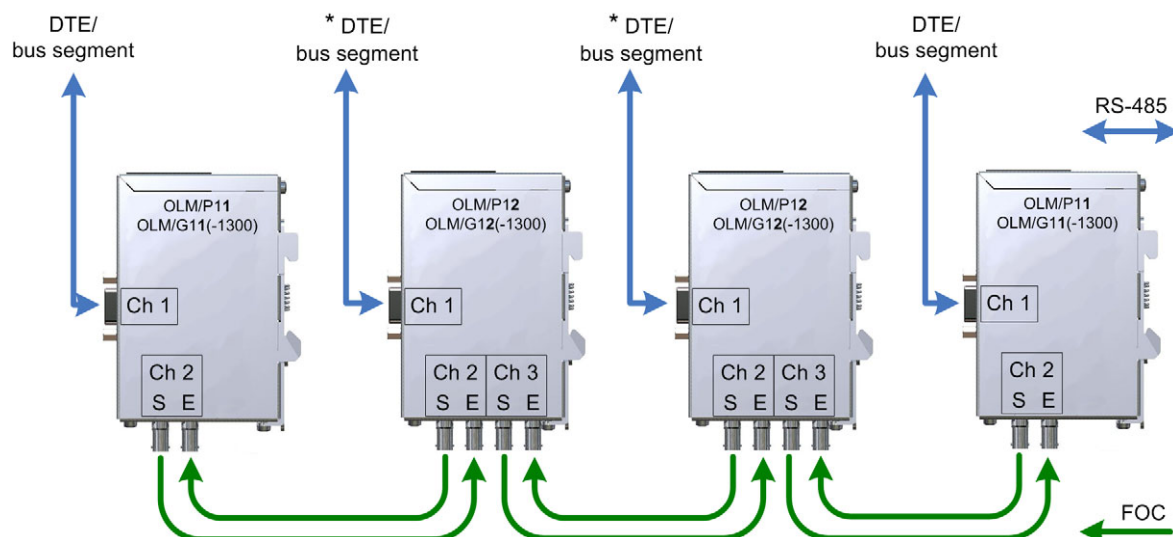

Figure 3-1 Network structure in a linear (bus) optical topology

* If OLM / P22 or OLM / G22 are used, an additional DTE or bus segment can be connected to Ch 0.

In a linear or bus structure, the single PROFIBUS OLMs are connected by two-fiber cables.

At the beginning and at the end of a line, modules with one optical channel are adequate, in-between modules with two optical channels are necessary.

If single point-to-point connections are required, they can be implemented with modules with one optical channel each.

The bus topology can be implemented with and without fiber-optic link monitoring. Fiber-optic link monitoring is recommended in homogeneous OLM networks (factory default).

Please note that to ensure correct operation, the following conditions must be kept to when configuring the network:

- The parameter MIN TSDR, described in the PROFIBUS standard EN 50170 /2/, must be set to a value ≥ 11 on all DTEs. This is usually the case but should be checked if permanent communication problems occur.
- Choose bus node addresses as low as possible when configuring your network, to reduce master timeouts that may occur due to disruptions.

You will find information on changing the setting in the documentation supplied by the manufacturer of your DTE.

3.1.1 Linear (bus) topology with fiber-optic link monitoring and segmentation

Use this mode especially when you want a disrupted fiber-optic cable segment to be separated from the rest of the network (see section 4.2.2.4). Only use this mode, if you only connect PROFIBUS OLM V4.0 or V3/V4.0 with each other.

Monitoring mechanisms:

- Send echo: yes
- Monitor echo: yes
- Suppress echo: yes
- Monitor: yes
- Segmentation: yes

In this mode, the individual fiber-optic links are monitored by the two connected modules.

If a module fails or a fiber-optic cable breaks or disturbances are detected on the optical transmission line, the fiber-optic link between the two OLMs is interrupted (segmented). The PROFIBUS network is separated into two (sub)networks each remaining functional on its own. The problem is indicated by the channel LEDs changing to red and by the signaling contacts of the two OLMs connected to the disturbed fiber-optic link. The segmentation is canceled automatically as soon as both modules recognize that the segmented fieldbus (sub)network is no longer disrupted based on test frames that they send out automatically. Note that if a problem occurs in networks with several active bus nodes, two logical token rings are formed. As a result, temporary network disturbances may occur due to double tokens or frame collisions when the full network is restored.

Note:

If modules with two optical channels are used at the end of a line, the unused optical channel must be set to the mode “bus without fiber-optic link monitoring”, so that it does not cause a broken fiber-optic cable signal (see section 4.2.3.4). Remember that the optical channels that are not connected must be protected against external light and pollution by protective caps.

3.1.2 Bus topology without fiber-optic link monitoring

Use this mode when you connect a PROFIBUS OLM with a different fiber-optic component according to the PROFIBUS guideline (optical/electrical converter), which does not send a frame echo and does not expect or tolerate a frame echo.

Monitoring mechanisms:

- Send echo: no
- Monitor echo: no
- Suppress echo: no
- Monitor: no
- Segmentation: no

In this mode, there is no monitoring of the individual fiber-optic links.

3.2 Star Topology

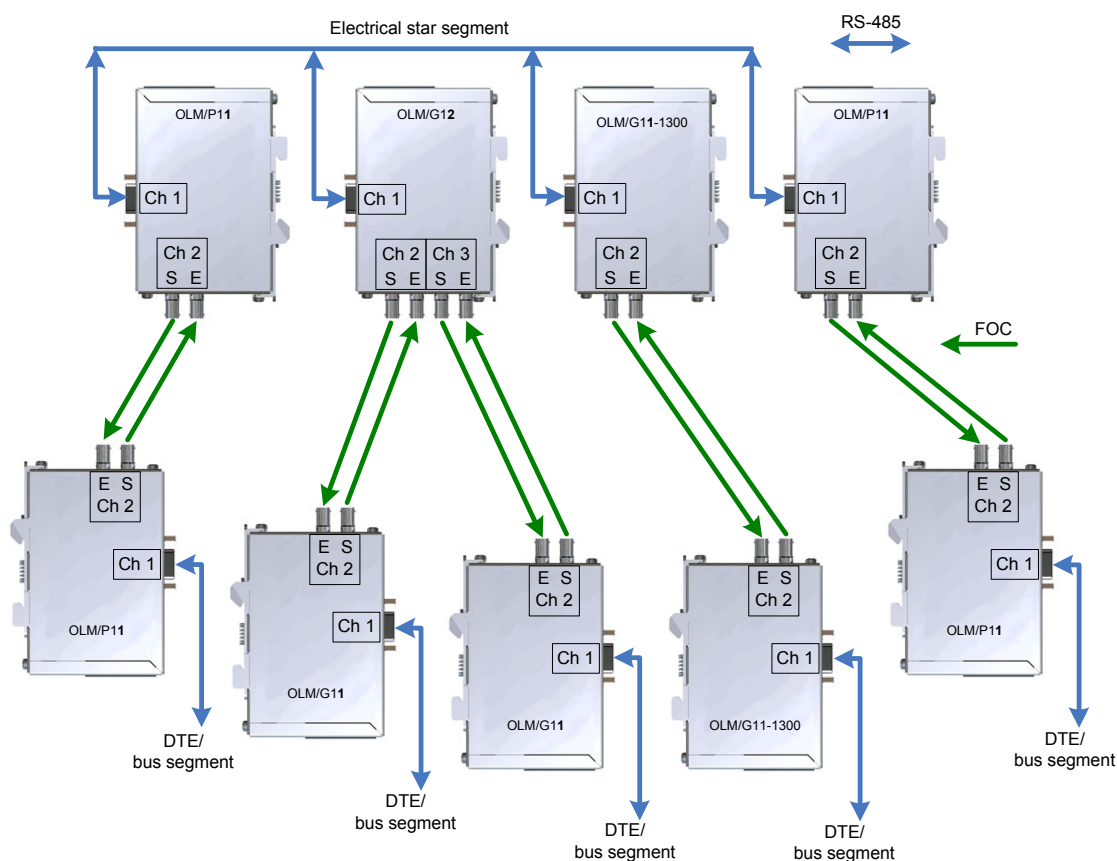

Figure 3-2 Network structure with an optical star topology

Several modules are grouped together to form an active PROFIBUS star coupler. Further modules are connected to this via two-core fiber-optic cables. The modules of the star coupler are interconnected via the electrical channel (electrical star segment). All OLM types for different fiber-optic cables (plastic, PCF, glass) can be combined via the electrical star segment.

Please note the following:

- CH1 / CH0 must be set to “Monitor off” (S0/S8 = 1) on all OLMs connected to the electrical star segment. This disables segmentation function of the RS-485 channel of this OLM to achieve high availability of the electrical star.
- Make sure that the electrical star segment is carefully wired. Keep its span as small as possible to avoid interference in the electrical star segment that can spread to the whole network. You can achieve this by positioning the OLMs directly next to each other on a DIN rail.
- Switch on the terminating resistors (see section 5.3) in the bus connectors at the two ends of the electrical star segments.
- If possible do not connect any bus nodes to the electrical star segment.

To set up an active PROFIBUS star coupler, modules with one or two optical channels can be used. To connect a DTE or an RS-485 bus segment to an active star coupler, modules with one optical channel are adequate.

When the monitoring on the optical channels is active, the fiber-optic links are monitored by the connected OLMs.

Note:

Unused optical channels you intend to use later to expand the network cause a broken fiber-optic cable signal if the monitoring is active. You can avoid this error message by setting unused channels to the mode “bus without fiber-optic link monitoring”. Remember that the optical channels that are not connected must be protected against external light and pollution by protective caps.

3.3 Ring Topology

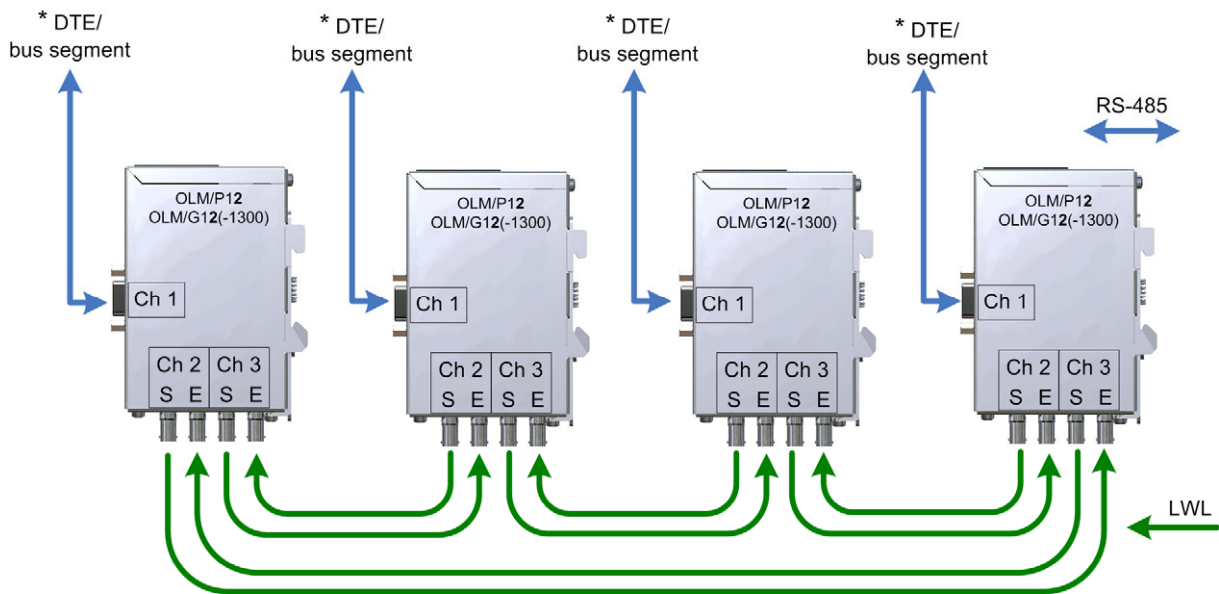

Figure 3-3 Network structure with a redundant optical ring topology

* If OLM / P22 or OLM / G22 are used, an additional DTE or bus segment can be connected to Ch 0.

This network topology is a special form of the bus topology. “Closing” the optical bus achieves high operational reliability in the network. A redundant optical ring can only be implemented using modules with two optical channels.

Monitoring mechanisms:

- Send echo: yes
- Monitor echo: yes
- Suppress echo: yes
- Segmentation: yes

The interruption of one or both fiber-optic cables between the modules is detected by the OLM and the ring becomes an optical bus.

If one module fails, only the DTEs connected to this module or the RS-485 segment are disconnected from the ring. The rest of the network itself stays functional as a bus. The problem is indicated by the LEDs of the two OLMs connected to the disrupted fiber-optic link and by the signaling contacts of these OLMs. The segmentation is canceled automatically as soon as both modules recognize that the segmented fieldbus (sub)network is no longer disrupted based on test frames that they send out automatically. The bus then closes again to form a ring.

Please note the following:

For correct operation, the following conditions must be met:

- Only use this mode, if you only connect PROFIBUS OLMs with at least version V3 with each other. Both optical channels must be set to the “redundant optical ring” mode on all PROFIBUS OLMs. All modules within a ring must be connected to each other over fiber-optic cables. There must be no RS-485 bus cable within the ring.
- The MIN TSDR parameter described in the PROFIBUS standard EN 50170 /2/ must be set to a value ≥ 11 on all DTEs. This is usually the case but should be checked if permanent communication problems occur.
- Choose bus node addresses as low as possible when configuring your network, to reduce master timeouts that may occur due to disruptions.
- If there is a failover (for example due to a cable break), there is failover time during which correct data transmission is not possible. To ensure bumpless bridging for the application, it is advisable to set the frame retry number on the PROFIBUS master to at least 3. To ensure a bumpless return from the optical bus to the optical ring once a problem has been eliminated, there must be no frame on the network at this time. This status occurs when the master sends a GAP query to an address lower than HSA. The master tries to address the device cyclically and waits for a reply at the longest until the configured slot time has elapsed (“GAP query”). The OLM recognizes this status and closes the optical bus to form an optical ring in the middle of this query sequence. This results in the **following two important configuration requirements** for the redundant optical ring:
 - The value of the parameter HSA (Highest Station Address) must be set on all DTEs so that there is at least one address between bus address 0 and the value HSA that is not occupied by a bus node, in other words there is at least one address gap. You can create this address gap simply by setting the HSA value one higher than the highest existing bus node address.

Notice

If this requirement is not or no longer met, the optical bus will no longer close to form a redundant optical ring after segmentation. In this case the error message (LED and signaling contact) of the two affected OLMs will not be cleared after eliminating the problem.

- The slot time must be set to about twice the value compared with a redundant network. See section 5.10 for further information. You will find information on changing the setting in the documentation supplied with your DTE or with the configuration software.

Notice

No glass fiber-optic cable may be connected to an OLM that uses plastic fiber-optic cable and vice versa.

3.3.1 Redundant Optical Ring with two OLMs

Setting up a redundant optical ring with two PROFIBUS OLMs can be seen as special case of the redundant optical ring and can be implemented with the following two configurations.

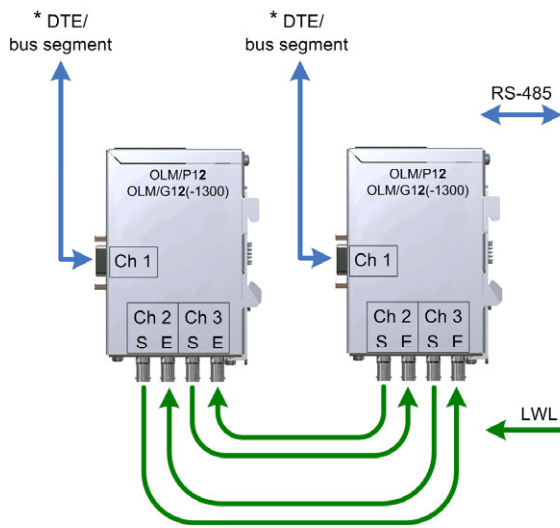

Figure 3-4 Configuration 1

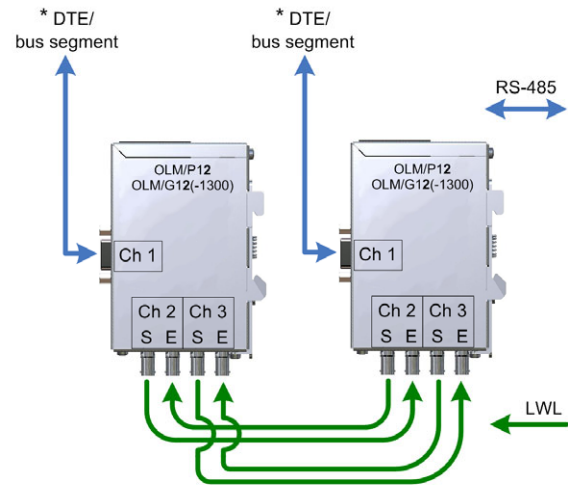

Figure 3-5 Configuration 2

* If OLM / P22 or OLM / G22 are used, an additional DTE or bus segment can be connected to Ch 0.

How the LEDs react in the redundant optical ring:

A frame received by any channel is passed on to all other channels. If the frame was received at an optical channel, it will also be sent back to the sender on the same channel as an echo and therefore serves as a monitoring frame to test the fiber-optic links between the OLMs.

The OLM recognizes whether a received frame is an echo or a frame that was forwarded. In the case of an echo frame, the channel LED stays off whereas in the case of a forwarded frame it will light up yellow. In networks with more than two OLMs, echo frames and forwarded frames will alternate quickly. Due to the extended display-time of at least 300 ms, all channel LEDs seem to be lit yellow continuously.

The channel LEDs may react differently in the redundant optical ring only if the following conditions are met:

1. The redundant optical ring consists of exactly two OLMs and the two fiber-optic links are of different length (difference > approx. 2 m).

Under these conditions, the receiving OLM will always receive a sent frame first on the channel with the shorter fiber-optic link. The channel signals this with a lit yellow LED. The frame on the other optical channel is interpreted as an "echo frame", the channel LED stays unlit. Since the fiber-optic cable lengths represent static variables, the display reaction is also static.

➤ **Configuration 1 (see Figure 3-4 Configuration 1, FOC1 < FOC2) , LED display:**

1. Situation, no FOC interruption:

OLM 1	OLM 2
SystemLED = lit green	SystemLED = lit green
CH1/0 LED = lit yellow	CH1/0 LED = lit yellow
CH2 LED = lit yellow	CH2 LED = is not lit
CH3 LED = is not lit	CH3 LED = lit yellow

2. Fault, FOC1 interrupted:

OLM 1	OLM 2
SystemLED = lit green	SystemLED = lit green
CH1/0 LED = lit yellow	CH1/0 LED = lit yellow
CH2 LED = lit red	CH2 LED = lit yellow
CH3 LED = lit yellow	CH3 LED = lit red

3. Fault, FOC2 interrupted:

OLM 1	OLM 2
SystemLED = lit green	SystemLED = lit green
CH1/0 LED = lit yellow	CH1/0 LED = lit yellow
CH2 LED = lit yellow	CH2 LED = lit red
CH3 LED = lit red	CH3 LED = lit yellow

➤ **Configuration 2 (see Figure 3-5 Configuration 2, FOC1 < FOC2) , LED display:**

1. Situation, no FOC interruption:

OLM 1	OLM 2
SystemLED = lit green	SystemLED = lit green
CH1/0 LED = lit yellow	CH1/0 LED = lit yellow
CH2 LED = lit yellow	CH2 LED = lit yellow
CH3 LED = is not lit	CH3 LED = is not lit

2. Fault, FOC1 interrupted:

OLM 1	OLM 2
SystemLED = lit green	SystemLED = lit green
CH1/0 LED = lit yellow	CH1/0 LED = lit yellow
CH2 LED = lit red	CH2 LED = lit red
CH3 LED = lit yellow	CH3 LED = lit yellow

3. Fault, FOC2 interrupted:

OLM 1	OLM 2
SystemLED = lit green	SystemLED = lit green
CH1/0 LED = lit yellow	CH1/0 LED = lit yellow
CH2 LED = lit yellow	CH2 LED = lit yellow
CH3 LED = lit red	CH3 LED = lit red

2. The redundant optical ring consists of exactly two OLMs and both fiber-optic cable connections are of exactly the same length.

Under these circumstances, that the receiving OLM receives a frame on both of the optical channels at the same time. To manage this case, the OLM prioritizes the two optical channels. By definition, the frame on one optical channel will then be taken as an echo (channel LED = off) and the frame on the other optical channel will then be taken as a forwarded frame (channel LED = yellow).

Due to the effect of jitter and the resulting sampling differences between the two optical input channels, it is possible that one or the other optical channel receives a frame first. Due to the extended display time of at least 300 ms. all channel LEDs are then lit yellow continuously.

➤ **Configuration 1/2 (FOC1 = FOC2), LED display A:**

1. Situation, no FOC interruption:

OLM 1	OLM 2
SystemLED = lit green	SystemLED = lit green
CH1/0 LED = lit yellow (continuous, flashing, flickering)	CH1/0 LED = lit yellow (continuous, flashing, flickering)
CH2 LED = lit yellow (continuous, flashing, flickering)	CH2 LED = lit yellow (continuous, flashing, flickering)
CH3 LED = lit yellow (continuous, flashing, flickering)	CH3 LED = lit yellow (continuous, flashing, flickering)

2. Fault, FOC1 interrupted:

see above

3. Fault, FOC2 interrupted:

see above

Generally:

Regardless of whether a channel LED is lit or not, all optical channels are monitored continuously in the redundant optical ring. If a channel LED is not lit, the frames circulating on this channel are used to monitor the transmission line. The productive communication is implemented over the channel with the LED lit yellow.

Without exception, faults are indicated by a red channel LED and by the signaling contact. We recommend that you connect the signaling contact for safe monitoring of the OLM.

4 Product Characteristics

4

4.1 Technical Specifications

Characteristics	Device type		
	OLM P11 V4.0 OLM P12 V4.0 OLM P22 V4.0	OLM G11 V4.0 OLM G12 V4.0 OLM G22 V4.0 OLM G12-EEC V4.0	OLM G11-1300 V4.0 OLM G12-1300 V4.0
Power supply			
Operating voltage	24 V DC safety extra low voltage permitted voltage range 18..32 V DC NEC Class 2		
Current consumption	max. 200 mA		
Output voltage for bus termination RS-485 (D-sub jack, pin 6)	5 V DC+5/-10%,		
Signaling Contact			
Function	floating contact, opens in case of error		
Voltage	CE: max. 50 V DC/30 V AC safety extra low voltage cULus: max. 30 V DC/30 V AC safety extra low voltage		
Current	max 1.0 A		
Signal transmission			
Transmission rate	9.6; 19.2; 45.45; 93.75; 187.5; 500 Kbps 1.5; 3; 6; 12 Mbps		
Transmission rate setting	automatic		
Bit error rate	<10 ⁻⁹		
Signal delay time (any input/output)	≤ 6.5 t _{Bit}		
Retimer			
Input (all channels)			
Signal distortion	± 30%		
Bit length	± 0.12%		
Output (all channels)			
Average bit length	± 0.01%		
Status signaling			
Device	LED "system", red/green together with signaling contact		
Electrical channel	LED yellow/red		
Optical channels	LED yellow/red		
Optical level	level display with green/yellow/red LED		
Safety			
IEC regulation	IEC 60950 (corresponds to EN 60950 and VDE 0805)		
UL-approval	according to type plate		

Characteristics	Device type		
	OLM P11 V4.0 OLM P12 V4.0 OLM P22 V4.0	OLM G11 V4.0 OLM G12 V4.0 OLM G22 V4.0 OLM G12-EEC V4.0	OLM G11-1300 V4.0 OLM G12-1300 V4.0
CSA-approval	according to type plate		
C-Tick approval	according to type plate		
FM approval	according to type plate		
Ex (hazardous area) approval	according to type plate		
Electrical channel			
Type	RS-485		
Input voltage stability	-7 V..+12 V		
Optical channels	OLM P11 V4.0 OLM P12 V4.0	OLM G11 V4.0 OLM G12 V4.0 OLM G12-EEC V4.0	OLM G11-1300 V4.0 OLM G12-1300 V4.0
Wavelength	660 nm	860 nm	1310 nm
Optical power that can be injected			
in glass fiber E 10/125 (9/125)	-	-	-19 dBm
in glass fiber G 50/125	-	-16 dBm	-17 dBm
in glass fiber G 62.5/125	-	-13 dBm	-17 dBm
in PCF S 200/230			
Optical transmit power "reduced"	-	-	-
Optical transmit power "default"	-17 dBm	-	-
in plastic fiber S 980/1000			
Optical transmit power "reduced"	-9.5 dBm	-	-
Optical transmit power "default"	-5 dBm	-	-
Sensitivity of receiver	-25 dBm	-28 dBm	-29 dBm
Overdrive limit receiver	-3 dBm	-3 dBm	-3 dBm
Range ³			
with glass fiber E 10/125 (0.5dB/km)	-	-	0..15 km
with glass fiber G 50/125 (3dB/km @860nm, 1dB/km @1310nm)	-	0..3 km	0..10 km
with glass fiber G 62.5/125 (3.5dB/km @860nm, 1dB/km @1310nm)	-	0..3 km	0..10 km
with PCF S 200/230			
Transmit power "reduced"	-	-	-
Transmit power "default"	0..400 m	-	-
with plastic fiber S 980/1000 (0.2dB/m)			
Transmit power "reduced"	0..50 m	-	-
Transmit power "default"	30..80 m	-	-
Connector	BFOC/2.5		
Electromagnetic compatibility			
Radiated emission	EN55022, limit value class A		
Conducted emission	EN55022, limit value class A		
Electrostatic discharge (ESD)	EN61000-4-2, ± 6 kV contact discharge		
Radiated RF	EN61000-4-3, 10 V/m 80 MHz..1 GHz		
Conducted RF	EN61000-4-6, 10 V 10 kHz..80 MHz		
Burst	EN61000-4-4, ± 2 kV on power supply, signaling contact and RS-485		

³ The distances between two OLMs may not be exceeded, regardless of the optical power budget.

Characteristics	Device type		
	OLM P11 V4.0 OLM P12 V4.0 OLM P22 V4.0	OLM G11 V4.0 OLM G12 V4.0 OLM G22 V4.0 OLM G12-EEC V4.0	OLM G11-1300 V4.0 OLM G12-1300 V4.0
Surge (with Blitzductor)	EN61000-4-5, on power supply lines ± 1 kV balanced ± 2 kV unbalanced on RS-485 bus lines ± 2 kV unbalanced		
Voltage interruption Voltage dips	EN61000-4-11, voltage reduction by >95% for 5 s voltage reduction by 30% for 10 ms voltage reduction by 60% for 100 ms and 1000 ms		
Climatic ambient conditions			
Ambient temperature during operation	-25 °C..+60 °C for OLMG12-EEC 0 °C..+60 °C for all other OLMs		
Storage and transport temperature	-40 °C..+70 °C		
Relative humidity	100%, condensing for OLMG1x-EEC <95%, non condensing for all other OLMs		
Mechanical ambient conditions			
Oscillation in operation	10..58 Hz, 0.075 mm deflection 58..150 Hz, 1 g acceleration		
Oscillation during transportation	5 Hz..9 Hz, 3.5 mm deflection 9 Hz..500 Hz, 1 g acceleration		
Vibration in operation	40 m/s ²		
Shock in operation	150 m/s ² , 10 ms		
Shock packed	250 m/s ² , 6 ms		
Free fall unpacked	10 cm		
Free fall packed	30 cm in product packaging 1 m in shipping packaging		
Miscellaneous information			
Degree of protection	IP40		
Dimensions	39.5 x 110 x 72.2 mm		
Housing material	stainless steel, 1.4016		
Weight	approx. 320 g		
Silicone	the device is free of silicone		
MTBF at 40 °C	145700 h (P11) 76900 h (P12) 76700 h (P22)	169900 h (G11) 90600 h (G12/EEC) 90200 h (G22)	152400 h (G11-1300) 80700 h (G12-1300)
MTBF at 85 °C	96500 h (P11) 60600 h (P12) 59800 h (P22)	106500 h (G11) 68800 h (G12/EEC) 67700 h (G22)	99400 h (G11-1300) 62900 h (G12-1300)

Table 4-1 Overview of the product characteristics

Notice: The resistance to ground (R_{TG}) for operation of an ungrounded PROFIBUS OLM V4.0 is 840 kOhm.

4.2 Installation

4.2.1 Safety related notices



Only use the PROFIBUS OLM in the way intended in these operating instructions. In particular, observe all warnings and safety-relevant notices.



Run the modules only with a safety extra-low voltage of a maximum of +32 V DC (typically +24 V DC) according to IEC 950 / EN 60 950 / VDE 0805. According to the UL/CSA-approval, the power supply unit must meet the requirements of NEC, Class 2. Protective measures must be taken to avoid the rated voltage of the equipment being exceeded by more than 40% by transient overvoltages. This is the case if the equipment is supplied exclusively by SELV circuits. Only the connectors supplied may be used for the electrical connection of the OLM, (applies also when replacement parts are used). When using the existing connectors (e.g. OLM V3), the proper contact cannot be guaranteed because of different pin diameters! The supplied connectors must also be plugged in to achieve IP40.



Observe the electrical limit values when connecting voltage to the signaling contacts: 50 V DC, 30 V AC (CE) / 30 V DC, 30 V AC (cULus). The connected voltage must also be a safety extra-low voltage according to IEC 950/ EN 60 950/ VDE 0805 and must to meet the requirements of NEC, Class 2 in accordance with the UL/CSA approval.

WARNING: If temperatures in excess of 70°C occur on the cable or at the cable feed-in point, or the temperature at the branching point of the cables exceeds 80 °C, special measures need to be taken. If the equipment is operated at an ambient temperature of 50°C - 60°C, use cables with a permitted operating temperature of at least 80 °C.



WARNING: – Explosion Hazard – Do not disconnect while circuit is live unless area is known to be non-hazardous.



DANGER: Never connect the PROFIBUS OLM to mains voltage.



Choose the installation location so that the climatic and mechanical limit values as specified in the technical specifications can be met.



WARNING: All PROFIBUS OLMs are approved for operation in the hazardous area zone 2 according to Ex nA IIC T4. In this case, the modules must be installed in a suitable enclosure (cabinet) providing degree of protection IP54 according to IEC 529. In this situation, the supplied connectors must be assembled. The fiber-optic bus lines may be laid in or through a Zone 1 hazardous area only with an OLM that is appropriately labeled (see type plate, see also section 6.4 Ex approval).

Note: If PROFIBUS OLMs are supplied via long 24 V supply lines or over networks, measures must be taken to prevent interference by strong electro magnetic pulses on the supply lines. These can occur, for example, due to lightning strikes or when heavy inductive loads are switched. The robustness of the PROFIBUS OLM against electromagnetic interference was verified by the Surge Immunity Test according to EN61000-4-5. For this test, overvoltage protection for the voltage supply lines is necessary. The Dehn Blitzductor VT AD 24V Type no. 918402 or a comparable protection element is, for example, suitable. Manufacturer: DEHN+SÖHNE GmbH+Co.KG Hans Dehn Str.1 Postfach 1640 D-92306 Neumarkt, Germany

Note: Under foreseeable circumstances, the accessible optical radiant power of the components used represents no danger and meets the requirements for class 1 according to IEC 60825-1 Ed.1.2:2001-08. Nevertheless, avoid looking directly into the transmitter or into the end of a fiber-optic cable.

4.2.2 General information on commissioning

Unpack the OLM V4.0 and its accessories and check that the consignment is complete and that there has been no damage during transportation. After unpacking, the device should be acclimatized for some time to avoid condensation after to storage in cold surroundings.

First choose the network topology suitable for your requirements. Commissioning of the modules then involves the following steps:

- Checking and, if necessary, setting of the DIL switches.
- Installation of the modules.
- Connection of the power supply and, if required, connection of the signaling contacts.
- Connection of the RS-485 bus line with installed bus connectors (if you use a bus topology, remember that the terminating resistors in the connectors at both ends of the line must be activated).
- Connection of the optical bus lines.

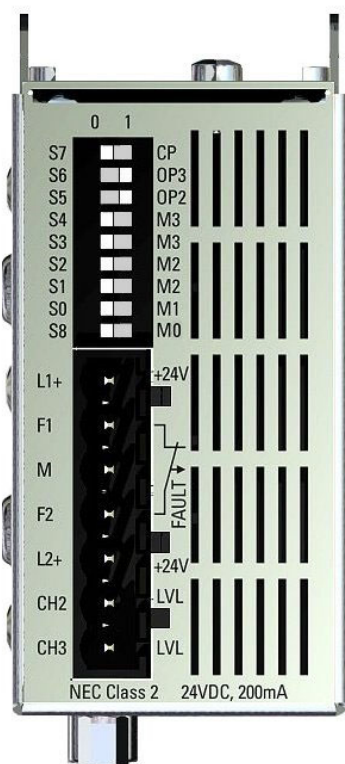

Figure 4-1 View of the OLM module from the top

Position of the DIL switches and of the terminal block for the power supply/signaling contacts/level measurement. The figure shows the factory default setting of the DIL switches (switches S0, S1, S2, S3, S4, S7 and S8 in position “0”, switches S5 and S6 in position “1”).

4.2.3 Setting compatibility, mode and transmit power

Please note the following:

The OLM must be switched off when changing the mode. You can achieve this for example by disconnecting the 5-pin terminal block.

4.2.3.1 Setting the compatibility

With DIL switch S7, you can enable or disable functional compatibility with devices of the previous generation SINEC L2FO OLM/P3, -P4, -S3, -S4, S3-1300 and S4-1300. The default setting of S7 is position 0 (compatibility disabled).

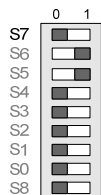

DIL switch S7 (compatibility) in position 0:

Compatibility with SINEC L2FO OLM/P3, -P4, -S3, -S4, -S3-1300, -S4-1300 disabled

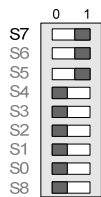

DIL switch S7 (compatibility) in position 1:

Compatibility with SINEC L2FO OLM/P3, -P4, -S3, -S4, -S3-1300, -S4-1300 enabled

By setting **DIL switch S7 to 1**, the **functionality compatibility** with optical link modules SINEC L2FO OLM/P3, OLM/P4, OLM/S3, OLM/S4, OLM/S3-1300 and OLM/S4-1300 **is enabled**. This mode is necessary for mixed operation of these modules with the OLM V4.0. Only set the S7 switch to position 1, if the PROFIBUS OLM is used as replacement or extension device in existing networks with SINEC L2FO OLM and a direct optical connection is required. To interconnect OLM V3 and OLM V4.0, switch S7 must be set to position 0 because these devices are directly compatible.

The effects of the DIL switches involving compatibility mode are described in Table 4-2.

The significance of the DIL switches of the OLM when S7=1 for:					
SINEC L2FO OLM/P3 and OLM/P4			SINEC L2FO OLM/S3 and OLM/S4, OLM/S3-1300 and OLM/S4-1300		
S6	Output power CH4		S6	Reserved	
0	Standard				
1	High				
S5	Output power CH3		S5	Reserved	
0	Standard				
1	High				
S4	Reserved		S4	Reserved	
S3	Reserved		S3	Distance	
			0	Extended	
			1	Standard	
S2	Redundancy		S2	Redundancy	
0	Off		0	Off	
1	On		1	On	
S1	Mode	Monitor	S1	Mode	Monitor
0	Line/ring	On	0	Line/Ring	On
1	Line	Off	1	Line	Off
S0	Reserved		S0	Reserved	
S8	Reserved		S8	Reserved	
OLM/P3: S6 reserved			OLM/S3, OLM/S3-1300: S2 reserved		

Table 4-2 DIL-switches in compatibility mode

4.2.3.2 Setting the mode

Notice! The following information is only valid for the default setting of S7 (S7 = 0), this means compatibility is disabled!

The mode of the electrical channel **CH1** is set with DIL switch **S0**. The mode of the electrical channel **CH0** is set with DIL switch **S8**. If the OLM has only one electrical interface, S8 has no function. The mode of optical channel **CH2** is set with DIL switches **S1** and **S2**. The mode of optical channel **CH3** is set with DIL switches **S3** and **S4**. If the OLM has only one optical interface, S3 and S4 have no function.

4.2.3.3 Setting the mode of the electrical channel (CH1)

Mode “electrical channel with segment monitoring“

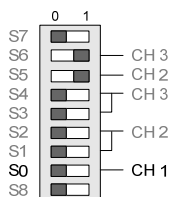

CH1 is set to this mode, when S0 is in position 0.

4.2 Installation

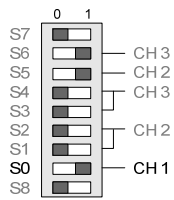

Mode “electrical channel without segment monitoring“

CH1 is set to this mode, when S0 is in position 1.

Note: This mode should only be set in the star segment of the star topology.

4.2.3.4 Setting the mode of the electrical channel (CH0)

Only for OLM / P22 and OLM / G22

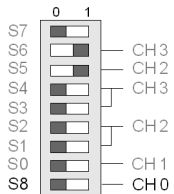

Mode “electrical channel with segment monitoring“

CH0 is set to this mode, when S8 is in position 0.

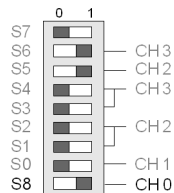

Mode “electrical channel without segment monitoring“

CH0 is set to this mode, when S8 is in position 1.

Note: This mode should only be set in the star segment of the star topology.

4.2.3.5 Setting the mode of the optical channels (CH2, CH3)

The mode can be set separately for each optical channel. Combinations of the modes “bus with and bus without fiber-optic link monitoring” are possible. Remember that the two optical channels connected via the fiber-optic cables must always be set to the same mode! When operating with devices that do not provide “fiber-optic link monitoring” this mode cannot be used and must be disabled on the OLM V4.

If mode “redundant optical ring” is used, both optical channels have to be set to this mode accordingly.

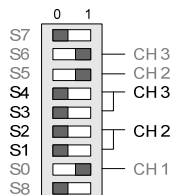

Mode “bus with fiber-optic link monitoring and segmentation”

CH2 is set to this mode, when S1 and S2 are in position 0.

CH3 is set to this mode, when S3 and S4 are in position 0.

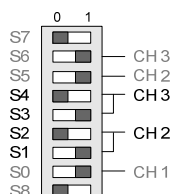

Mode “bus without fiber-optic link monitoring”

CH2 is set to this mode, when S1 is in position 1 and S2 is in position 0.

CH3 is set to this mode, when S3 is in position 1 and S4 is in position 0.

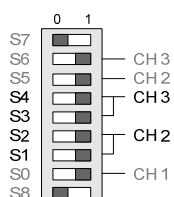

Mode “redundant optical ring“

CH2 is set to this mode, when S1 and S2 are in position 1.

CH3 is set to this mode, when S3 and S4 are in position 1.

Note: Remember that both optical channels of a module must be set to the same mode.

4.2.3.6 Reducing the optical transmit power for OLM/P11, OLM/P12, and OLM / P22

Notice! The following information is only valid for the default setting of S7 (S7=0)!

The OLM/P11, OLM/P12, and OLM / P22 have a high optical transmit power. Connecting these modules with non-OLM devices via plastic fiber-optic cables can lead to optical overdrive, especially if short cables are used. In this case, the optical transmit power can be reduced by approx. 60% (3.8 dB).

The optical transmit power of **CH2** is set with DIL switch **S5**.

The optical transmit power of **CH3** is set with DIL switch **S6**.

S6 has no function for the OLM/P11.

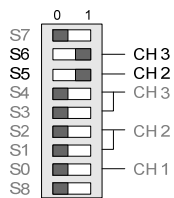

Leave S5 in position 1 (default) if the fiber-optic link on CH2 works correctly in this position.

Leave S6 in position 1 (default) if the fiber-optic link on CH3 works correctly in this position.

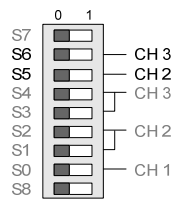

Set S5 to position 0 (reduced) if overdrive of a non-OLM device occurs on CH2 when plastic fiber-optic cables are used.

Set S6 to position 0 (reduced) if overdrive of a non-OLM-device occurs on CH3 when plastic fiber-optic cables are used.

Note:

When using PCF fibers, the default transmit power must be set (S5 or S6 in position 1).

If OLM / P11 V4.0, OLM / P12 V4.0, or OLM / P22 V4.0 is operated along with OBTs, IM151-1 FO, CP 5613 FO/CP 5614 FO, IM 467 FO, CP 342-5 FO or IM 153-2 FO devices using S 980/1000 plastic fiber cables, the devices must be interconnected by fiber-optic cables with a minimum length of 30 m (see Figure 4-2). As an alternative, a fixed attenuator with an attenuation value between 5 dB and 15 dB can be used. The fixed attenuator must be installed into the OLM receiver line. If PCF fibers S 200/230 are used, neither a minimum line length nor an attenuator is necessary.

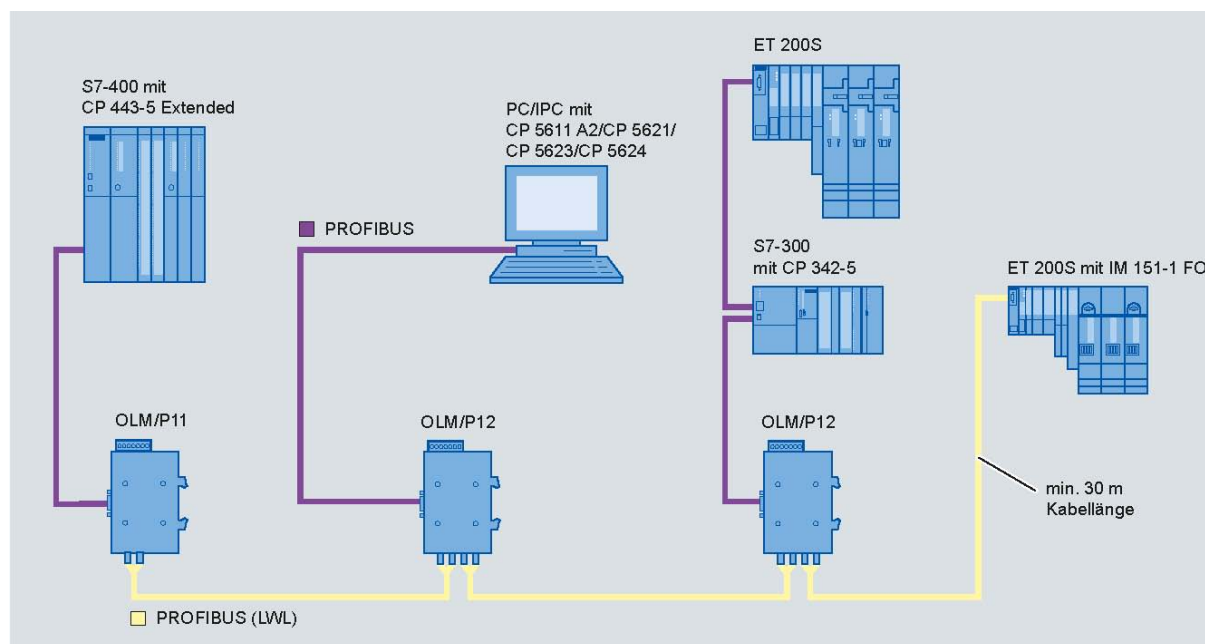

Figure 4-2 Minimum cable length for use of plastic fiber S 980/1000 without fixed attenuator

4.2.3.7 DIL Switches S5 / S6 in OLM V4-G11/G12/G22/G11-1300/G12-1300

In OLM V4 devices for glass FOC, the DIL switches S5 and S6 do not have a function (reduction of optical transmit power not possible). Nevertheless, if the OLM V4 is used along with OLM V3-G11/G12/G11-1300 and G12-1300 devices, the DIL switches S6 and S5 of the OLM V3 **must** be set to "0" in order to avoid interference due to the internal design of the OLM V3 devices.

4.2.3.8 Mixed operation of OLM V4 with OLM V2 (SINEC L2FO)

If OLM V4 modules are used along with OLM V2 (SINEC L2FO) modules, the bus terminating resistors for the second RS-485 port must be activated on the OLM V2 if the port is not used. This is done by setting DIL switches S3 and S4 (termination) to ON.

5 Installation and Maintenance

5.1 Installation

5.1.1 Installation instructions

Electromagnetic compatibility

Electromagnetic compatibility involves all questions regarding electric, magnetic and electromagnetic emission effects. To avoid disturbing influences on electrical installations, these effects must be reduced to a minimum. The construction of device, correct connection of bus lines and the suppression of self inductances are essential limitation measures. See also the note in section 4.2.1 (protecting against lightning strikes).

Suppression of self inductances

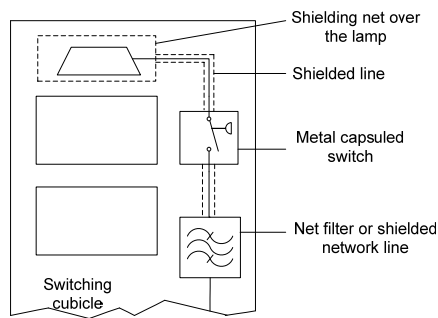

Figure 5-1 Measures to suppress luminescent lamps in a cubicle

- Connect self inductances to a suppression circuit. Self-inductance in relays and fans etc. produces disturbance voltages that are far higher than the operating voltage. These disturbance voltages can influence electronic devices. The disturbance voltages cause by inductors must be limited at the emission source by connecting suppression circuits (diode or RC circuit). Only use suppressors that are intended for use with your relay or fan.

➤ Switching cubicle illumination

Use light bulbs for the switching cubicle illumination, e.g. LINESTRA lamps. Avoid the use of luminescent lamps because these produce noise fields. If you cannot avoid using luminescent lamps, the measures described in Figure 5-1 will be necessary.

Arrangement of devices and cables

- Maintaining clearance to reduce noise

A both simple and effective way of reducing disturbing influences is to maintain clearances between the culprit and victim device or cable. Inductive and capacitive disturbances decrease with the square of the distance between the elements involved. This means that doubling the distance reduces the effect of the disturbance by a factor 4. If "geographic" considerations are taken into account in the planning of a building or a cubicle, these measures can usually be implemented very cheaply.

Please note the following:

A minimum distance of 15 cm must be maintained between an OLM and a load switching element (e.g. contactor, relay, temperature control, switch, etc.). This minimum clearance is measured between the outside edges of the components and must be adhered to in all directions around an OLM. The power supply lines (24 V DC) of the OLM must not be laid in the same cable duct as power lines (load circuits).

The lines +24 V DC and GND should be twisted with each other.

- Recommendations on the arrangement of devices and lines with the aim of achieving the lowest mutual influence possible can be found in EN 50174-2.
- For applications in environments with heavy electromagnetic interference and for use in shipbuilding, the retry value in the PROFIBUS master must be set to 4.
- Bus cable shields.
Note the following measures for shielding lines:
 - Use completely shielded SIMATIC NET PROFIBUS cables. The shields of these cables have a density high enough to meet the legal requirements for disturbance emission and immunity.
 - Always connect the shields of bus cables at both ends. The legal requirements for emissions and immunity can only be met by connecting the shield of the bus cables at both ends (CE mark).
 - Secure the shield of the bus cable to the connector housing or the cable clamps.
 - In stationary use, it is advisable to strip the insulation of the shielded cable over the entire length damaging it and to lay it on shielding/grounding rail.

Note:

If there are potential differences between the grounding points, an unduly high compensating current may flow over the shield connected at both ends. Under no circumstances disconnect the shield of the bus cable to solve the problem.

The following solution is permissible.

Install an extra equipotential bonding cable parallel to the bus cable and this can then take up the shield current.

Shield connections

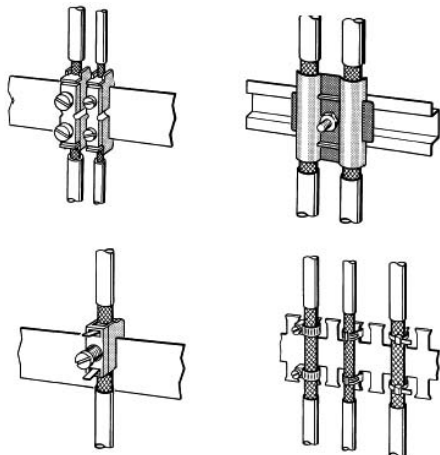

Figure 5-2 Securing shielded cables with cable clamps and cable retainers (schematic image)

Please note the following points when connecting the cable shield:

- Connect the shield braid with cable clamps made of metal.
- The clamps must surround the shield making good contact over a large area (see Figure 5-2).
- Only contact the SIMATIC NET PROFIBUS cables via the copper braid shield and not via the aluminum foil shield. The foil shield is applied to one side of a plastic foil to increase the tensile strength and therefore is not conductive!
- The shielding of all cables entering a switching cubicle from outside must make large area contact with chassis ground.
- The braid shield of the cables must not be damaged when stripping the cable jacket. Tin-plated or galvanically stabilized

surfaces are ideal for good contact between grounding elements. With tinned surfaces, the necessary contact must be established using screws. Painted or varnished surfaces at the contact points are unsuitable.

- Shield clamps or contacts must not be used as strain relief. The contact to the shielding rail could deteriorate or be broken altogether.

Optical link power budget, aging and environmental requirements

When using OLM V4.0 devices, make sure that they are not exposed to high temperatures for no good reason. The aging of the devices increases radically in high temperatures. The same applies to the connected fiber-optic cables. They age faster under the influence of temperature and high humidity. The deterioration caused by humidity especially applies to plastic fiber-optic cables.

The described deterioration of devices and fiber-optic cables is offset by the link power margin. This is obtained from the difference between the receiver sensitivity and the minimum input optical power (see section 4.1) along with the cable attenuation that derives from the maximum operating distance.

Example:

OLM/G12, wavelength 860 nm, fiber 62.5/200 μm

$P_{\text{send}} = 13 \text{ dBm}$

$P_{\text{receiver}} = 28 \text{ dBm}$

optical link margin = $28 \text{ dBm} - 13 \text{ dBm} = \underline{15 \text{ dBm}}$

max. line length = 3 km

attenuation = 3.5 dB/km @860 nm

max. line attenuation = $3.5 \text{ dB/km} * 3 \text{ km} = \underline{10.5 \text{ dB}}$

optical power margin = optical link power budget – max. line attenuation

= $15 \text{ dBm} - 10.5 \text{ dBm} = \underline{4.5 \text{ dBm}}$

This link power margin may not be infringed on by the user, because it may lead to errors at the optical interface!

You should also remember that the maximum line lengths are only valid for unspliced cables. If splices are used in the configured plant, their loss must be added to the cable loss.

5.1.2 Connecting optical cables



Figure 5-3 View of the module from below with optical channels 2 and 3 (device with two optical channels)

- Connect the single modules via a two-core fiber-optic cable with BFOC/2.5 connectors.
- Make sure
 - that the end faces of the optical connectors are clean.
 - that always one optical input ψ and one optical output ζ are interconnected (“crossover connection”). The BFOC sockets of a channel that belong together are marked on the lower part of the front panel.
 - that the optical connector is securely locked to the BFOC socket (bayonet connector must be locked).
 - that the tip of the BFOC connector is inserted completely into the fiber-optic cable socket when using single mode fiber-optic cables. If necessary, push the connector into the socket using anti-kink sleeve to make reliable contact.
- Make sure there is adequate strain relief for the fiber-optic cable and keep to the minimum bending radii of the fiber-optic cables (see note below).
- Close unused BFOC sockets with the supplied protective caps (note: An unused optical channel should be set to the “bus without fiber-optic link monitoring“ mode so that it does not cause a broken fiber-optic cable signal). Incoming external light can disturb the network, especially if the area is bright. Intruding dust can destroy the optical components.
- Keep to the maximum length of the fiber-optic cables and the possible fiber types, as shown in Table 2-1, page 4. and in the technical specifications, section 4.1.
- Test the quality of the link using the measurement socket after installing the optical network. The values must be within the permissible range according to section 5.6.

Note

The laying of fiber-optic cables requires special measures. Mechanical stress such as traction, pressure or kinking must be avoided. The cable manufacturers specify minimum bending radii for fiber-optic cables both during installation and operation. The bending radii and the requirements when laying cables depend largely on the cable type used and must therefore be checked up in the instructions in the relevant data sheets. Ignoring these requirements may lead to higher attenuation values and, in the worst case (extreme bending), to destruction of the fiber-optic cable.

5.2 Installation of the Modules

Installation options

The OLM modules can either be mounted on a 35 mm rail according to DIN EN 50022 or on a flat surface with the help of a mounting plate.

- Choose the location so that the climatic and mechanical limit values listed in the technical specifications can be met.
- Make sure there is enough space to connect the bus and voltage supply lines.
- Connect the fiber-optic cables before you install the modules. This makes it easier to connect the fiber-optic cables.
- Only install the modules on a rail or a mounting plate that is grounded with low resistance and inductance. No other grounding measures are necessary.

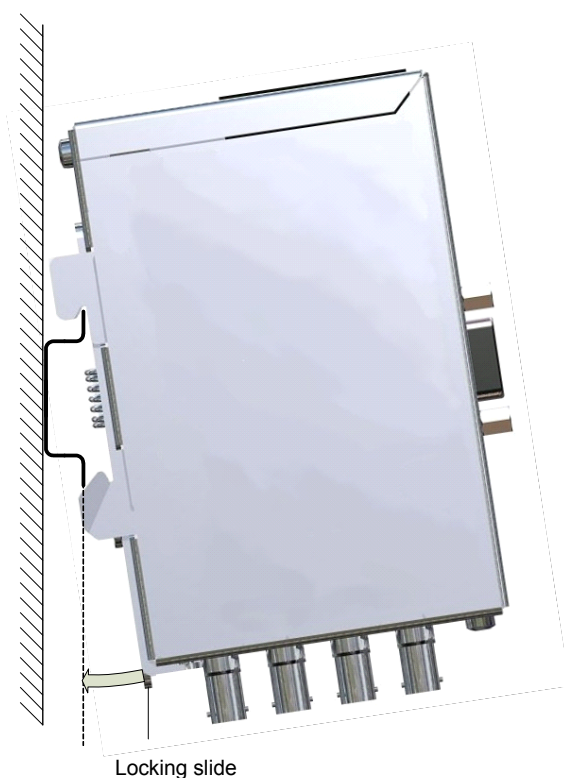

Installation on a DIN rail

- Fit the upper securing hooks onto the rail and push in the lower part towards the rail, as shown in Figure 5-4, until it locks audibly in place. To uninstall the module, pull the locking slide downwards.

Figure 5-4 Installation of a module on a standard DIN rail

Installation on a mounting plate

- Unscrew the 3 screws on the right side of the OLM (the side with the type label).
- Fix with these screws the mounting plate (MLFB: 6GK1503-8AA00).
- Now fix the OLM at the wall or at a cubicle plate.
- Make sure there is a reliable and permanent electrical connection between the mounting plate and surface, for example by using toothed washers.

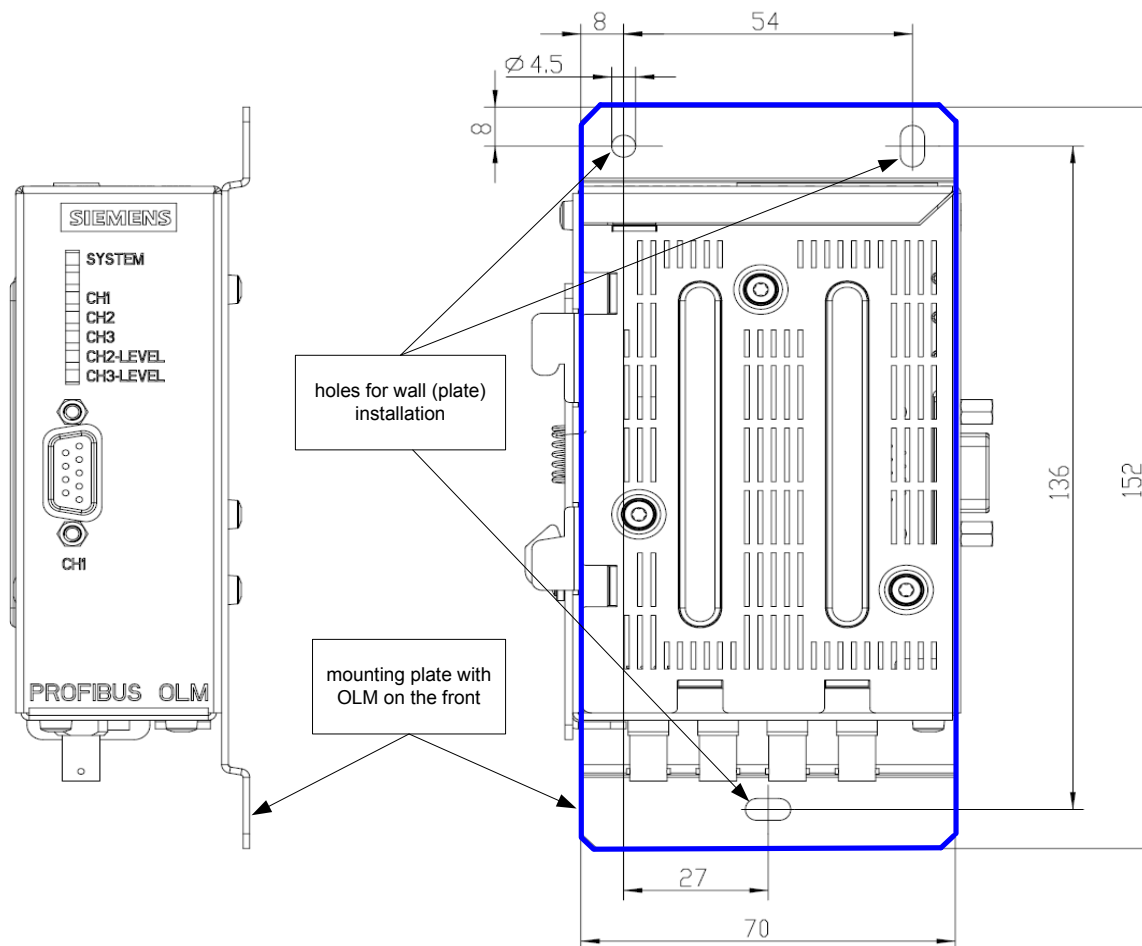

Figure 5-5 Installation of a module with a mounting plate

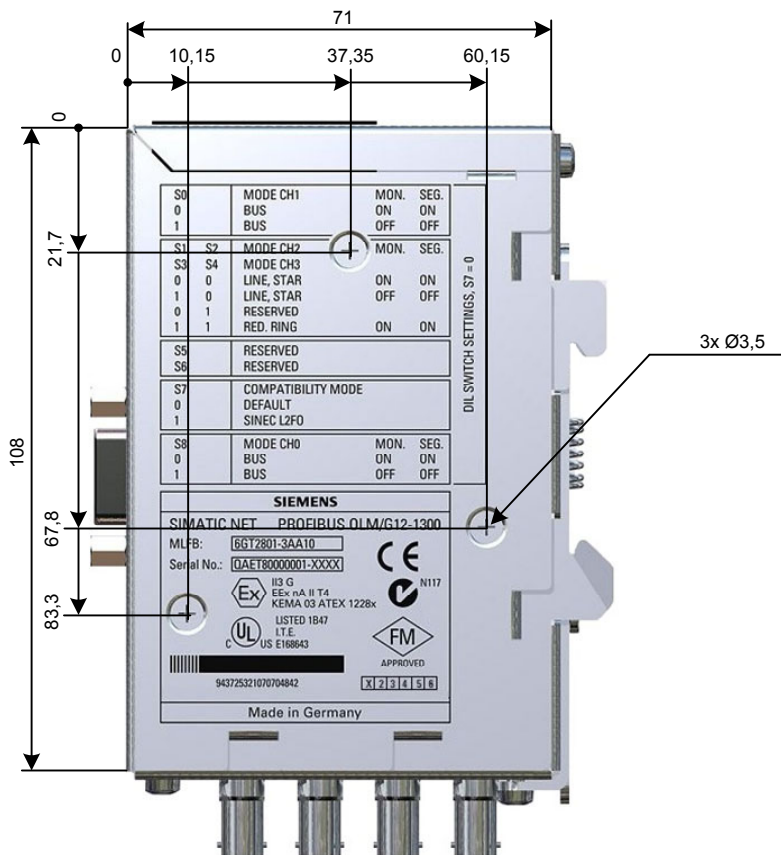

Figure 5-6 Drilling measures for the mounting plate, all dimensions are millimeter

5.3 Connection of the Electrical RS-485 Bus Cables

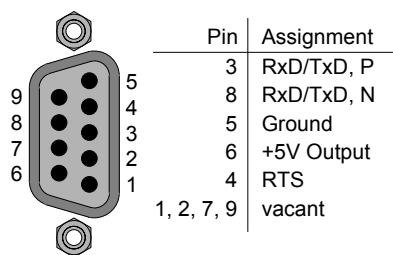

Figure 5-7 Electrical port, connector assignment D-sub jack

The modules are equipped with one or two electrical ports with RS-485 level. They are designed as 9-pin D-sub jack with screw locking mechanism (inner thread UNC 4-40). The pin assignment corresponds to the PROFIBUS standard assignment. A short-circuit proof 5 V output for the supply of external pull-up/pull-down resistances is available at pin 6. The resistances must have a power loss of at least 0.25 W. The RS-485 bus cables RxD/TxD, N and RxD/TxD, P are galvanically isolated from the 24 V supply voltage within the SELV limits (functional isolation). The RS-485 interface is electrically connected with the housing.

- Only use shielded twisted pair for the RS-485 bus cables as described in the manual “SIMATIC NET PROFIBUS Networks”. Do not exceed the segment lengths specified there.
- Connect the RS-485 bus segment via a PROFIBUS connector. If the module is at the beginning or at the end of a bus segment, this connector must have an active bus terminator.
- All PROFIBUS bus connectors of the network must be screwed securely to the RS-485 ports.
- Connecting or removing the bus connector or loosely connected bus connectors or bus wires not secure inside the connectors can lead to disruptions in the optical and electrical network.
- Connect or remove the RS-485 bus connector sharply and without tilting or levering the connector.
- Disconnect the RS-485 bus cable from the OLM when there is no device at the other end or when there is no power supplied to it. Otherwise the open line acts like an antenna and is susceptible to noise.
- In order to minimize disturbances, keep to the following order when connecting an RS-485 bus cable to a PROFIBUS OLM when the network is active:
 1. Plug the RS-485 bus connector onto the relevant device (e.g. the programming device) and secure it with the screws.
 2. Insert the RS-485 bus connector in the PROFIBUS OLM with a sharp movement and without tilting the connector.Carry out the steps in the reverse order to disconnect a device from the network.
- Make sure that the bus segment connected to the RS-485 port is terminated at both ends. Only use a connecting cable that is terminated at both ends to connect a single device.
- If temperatures in excess of 70 °C can occur on the cables or their insertion points or the temperature at cable branching points can exceed 80 °C, special measures must be taken. For ambient temperatures of 50 °C, cables with a temperature rating for at least 80 °C should be used.

Compatibility notice:

In the OLM V3, pin 2 was additionally connected with ground and pin 1 with the shield. This does not conform with the relevant standard EN 50170 /2/. This presents no problem, when cables complying with the PROFIBUS standard are used. When installing in an existing cabling system, check the pin assignment and modified it if necessary.



Please note the following safety information:

Do not connect RS-485 bus cables to the OLM that are laid completely or partly outside buildings. Lightning strikes in the vicinity could otherwise destroy the modules. If the bus exits the building, use fiber-optic cables!

5.4 Connecting of the Operating Power Supply

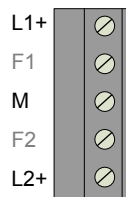

Figure 5-8 Operating power supply, pin assignment 5-pin terminal block

The terminal block can be removed from the device to allow cables to be connected.

- Supply the module only with a stabilized **safety extra-low voltage** of a maximum of +32 V (typically +24V) according to IEC 950 / EN 60 950 / VDE 0805. According to the UL/CSA-approval, the power supply unit must meet the requirements of NEC, Class 2. This can be supplied via the 5-pin terminal block on the top of the module.
- To increase the operational reliability, the module can be supplied redundantly via the terminals L2+ / +24 V DC* and M. If the regular supply voltage fails, the module automatically switches to the redundant power supply. There is no load splitting between the individual power supplies. The signaling contact does not indicate the failure of one of the 24 V supplies. To monitor the power supply, the supplies and the signaling contact must be connected to an input module.

Latches on the terminal block ensure a secure connection to the device and avoid polarity reversal.

5.5 Connecting the Signaling Contact Wires

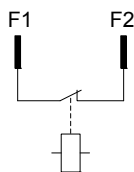

Figure 5-9 Signaling contact relay with floating contacts; In case of error, the contact is open

The terminal block can be removed from the device to allow wiring to be connected.

A relay with floating contacts is available for the signaling contact on the 5-pin terminal block on the top of the module. This relay can be used to signal problems in the network and on the modules. If a problem occurs, the contact is opened. This means that a total power outage is also signaled.

The problems indicated by the signaling contact are listed in section 5.7. Limit values of the signaling contact:

- maximum switching voltage 50 V DC; 30 V AC
- maximum switching current 1.0 A

The voltage connected to the relay must be a safety extra-low voltage according to IEC 950/ EN 60 950/ VDE 0805 and must meet the requirements of NEC, Class 2 in accordance with the UL/CSA approval.

- Connection assignment 5-pin terminal block:
Terminal F1 and F2.

- Please make absolutely sure that the terminals of the 5-pin terminal block are connected up correctly. Make sure there is adequate electrical insulation of the connecting cables to the signaling contacts, especially if you are using voltages higher than 32 V. Connecting up wrongly can lead to the destruction of the modules.

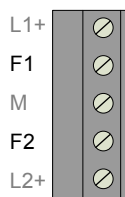

Figure 5-10 Signaling contact, pin assignment 5 pin terminal block

5.6 Receive Level of the Optical Channels

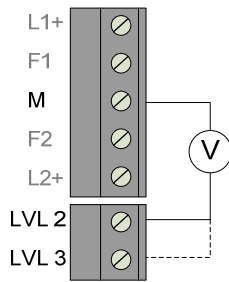

Figure 5-11 Position of the level recording connections

The receive level of the two optical channels CH2 und CH3 can be measured using a standard voltmeter via the measurement sockets. The voltmeter can be connected and disconnected while the device is operating. The OLM is protected against a short circuit at the measurement sockets; data transmission is not influenced. The receive level of the two optical channels can be read in on a PLC using floating high impedance analog inputs.

This allows

- the incoming optical power to be documented, e.g. for later measurement (aging, damage)
- a good/bad test to be carried out (limit value).

The measurement must be performed with a high-resistance, ungrounded voltmeter. The ground connector must not be connected to the housing; otherwise the data traffic could be disturbed. To meet the EMC requirements, the length of the connected measuring cables must not exceed 3 m. The quality of the bus traffic can be estimated based on the receiving levels in the following diagram:

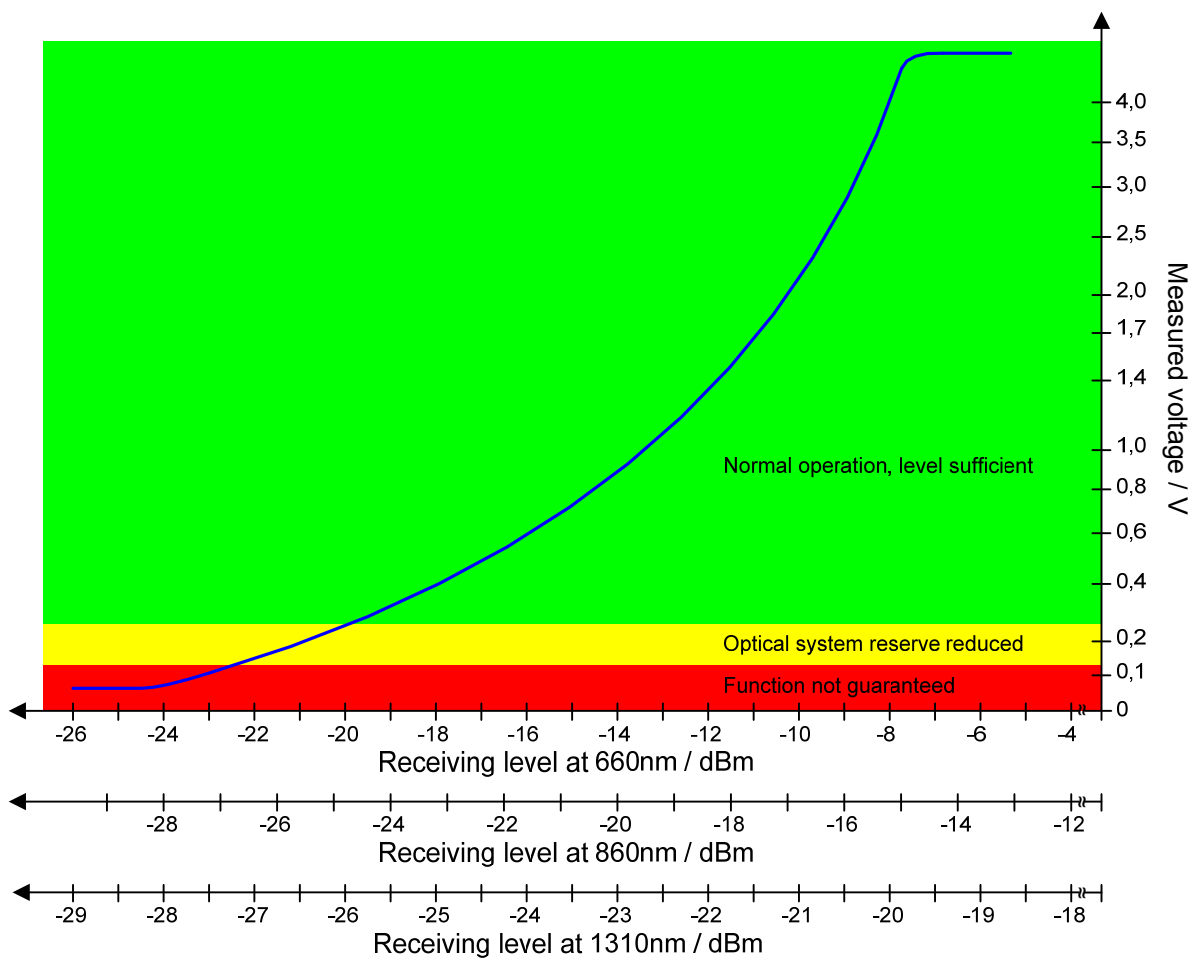

Figure 5-12 Relationship between measured output voltage and signal quality

Notes:

For a valid measurement, that the partner OLM at the other end of the fiber-optic cable must send normal PROFIBUS frames. This can be recognized by the LED display of the partner OLM (see section 5.7.1).

The output voltages at the measurement sockets are influenced by many factors:

- strength of the optical transmit power of the partner OLM
- ambient temperature of the optical transmitter and receiver
- attenuation of the transmission line
- transmission rate used

The measurement sockets are therefore not intended as a substitute for a calibrated level measuring device with a calibrated light source. The value obtained only serves to classify the received optical signals in 3 classes:

- **good** (normal operation, green) 5V > U > 240 mV
- **critical** (optical link margin reduced, yellow) 120 mV ≤ U ≤ 240 mV
- **bad** (functionality not guaranteed, red) U < 120 mV

The measurement must be performed with a standard ungrounded and high-resistance voltmeter. The internal resistance of the measurement sockets is approx. 30 kΩ. A connection from the measurement sockets or of reference potential to the OLM housing is not permitted.

When an OLM of the SINEC L2FO range is connected, the OLM V4 LED level indicator has no meaning. The measurement sockets cannot be used.

5.7 LED Displays and Troubleshooting

5.7.1 LED displays



Figure 5-13 LED displays on the front panel

LED display		Possible causes	Signaling contact
System	■ lit green	- The transmission rate was detected and the voltage supply is ok	does not signal
	□ not lit	- Voltage supply outage (complete outage, with a redundant supply, outage down of both supply voltages) - Voltage supply connected wrongly - Module defective	signals
	■ flashes red	Transmission rate not yet detected - There is no transmitting bus node - No connection to a partner module sending frames - Transmit and receive fiber-optic cables are swapped over - Transmission rate does not correspond to the PROFIBUS standard - Only one single bus node is connected, which only sends token to itself. After activation of a second bus node, the display must change (token frames are not enough to set the transmission rate) - The connected RS-485 segment is only terminated at one side	does not signal
	■ ■ flashes red/green	Transmission rate detected but - The slot time of the network could not be detected yet (network parameter HSA set too low, there is no transmitting bus node) - One optical channel is set to “redundant optical ring“ mode but the second one is not (this mode must always be set on both optical channels) - The value for the slot time of the network is set too low	does not signal
CH1, CH0 electrical	■ lit yellow	Signals are received on the RS-485 bus lines.	does not signal
	□ not lit	Bus node is not connected, does not signal - Connected bus node is not turned on - Interruption ⁴ of one or both cores of the RS-485 bus line - Short circuit ¹ or ground fault of cores of the RS-485 bus line	does not signal
	■ flashes red/lit red	Sporadic disturbances because of - Insufficient shielding of the RS-485 bus cable - Open bus cable, this means the RS-485 bus cable is only connected at one end - RS-485 segment is not terminated or only at one end - Removal/insertion of an RS-485 bus terminal or terminating plug Permanent problem because - Cores A and B of the RS-485 bus cable have been swapped over - Short circuit ¹ on the RS-485 bus cable - Transmission time exceeded due to a bus node in a bus segment connected to channel 1 or 0 - Module and other bus nodes connected over channel 1 or 0, transmit at the same time (e.g. because of duplicate address assignment or slot time set too low or when restoring after segmentation in the optical line, see section 3.1.1) - RS-485 driver of the module defective (e.g. after lightning strike)	signals
CH2, CH3 optical	■ lit yellow	Mode “Bus with fiber-optic link monitoring” and “redundant optical ring“ PROFIBUS frames are received on the optical channel	does not signal

⁴ Depends on the cable length between RS485 interface and fault, and on baud rate. Can vary from one example to another.

LED display	Possible causes	Signaling contact
<ul style="list-style-type: none"> <input type="checkbox"/> not lit 	<p>Transmission rate not detected yet – LED “System“ flashes red</p> <ul style="list-style-type: none"> - There is no transmitting bus node - Transmit and receive fiber-optic cables swapped over -No partner module connected or partner module is not turned on - Connected partner module is defective <p>Transmission rate is detected – LED “System” is lit green</p> <ul style="list-style-type: none"> - When the mode “redundant optical ring“ is set, the optical channel operates as standby channel. There is no problem in the OLM or on the fiber-optic cable. - If one of the modes “bus with fiber-optic link monitoring...” is set, no frames are received on the optical PROFIBUS channel. There is no error in the OLM or on the fiber-optic cable. 	<p>does not signal</p>
<ul style="list-style-type: none"> <input type="checkbox"/> flashes yellow 	<p>Transmission rate is detected – LED “System” is lit green or flashes red/green</p> <ul style="list-style-type: none"> - There is no transmitting bus node (fiber-optic cable connection is ok) 	<p>does not signal</p>
<ul style="list-style-type: none"> <input type="checkbox"/> lit red 	<ul style="list-style-type: none"> - Transmit and receive fiber-optic cables are swapped over - No partner module connected or partner module is not turned on - Connected partner module is defective - Transmission time exceeded by the connected partner module - Interruption of a fiber-optic cable - Fiber optic cable to the partner module longer than permitted - Loose contact at a fiber-optic cable connector - Fiber in the fiber-optic cable is loose - When the channel LED of the two concerned OLMs continues to be lit red after clearing a fiber-optic cable fault in the redundant optical ring check that the setting of the parameter HSA described in section 3.3 is correct 	<p>signals</p>
<ul style="list-style-type: none"> <input type="checkbox"/> <input type="checkbox"/> flashes red/yellow 	<ul style="list-style-type: none"> - Periodically occurring error (see above) loose contact at a fiber-optic cable connector - Fiber in the fiber-optic cable is loose - Only one single bus node is connected, which only sends token to itself. After the activation of a second participant the LED display should stop 	<p>signals</p>
<ul style="list-style-type: none"> <input type="checkbox"/> lit yellow 	<p>Mode “bus without fiber-optic link monitoring”</p> <p>PROFIBUS frames are received on the optical channel</p>	<p>does not signal</p>
<ul style="list-style-type: none"> <input type="checkbox"/> Not lit 	<ul style="list-style-type: none"> - There is no transmitting bus node - Transmit and receive fiber-optic cables are swapped over - No partner module connected or partner module is not active - Connected partner module is defective 	<p>does not signal</p>
<p>CH2, CH3 Level</p> <ul style="list-style-type: none"> <input type="checkbox"/> Lit green <input type="checkbox"/> lit yellow <input type="checkbox"/> Lit red 	<p>Receiving level adequate, normal operation</p> <p>Receiving level critical, link power margin reduced</p> <p>Receiving level inadequate, function not guaranteed</p>	<p>not relevant</p>

Table 5-1 Meaning of the LED displays and indication by the signaling contact

5.7.2 Troubleshooting

This section will help you to localize the problem after an error message (LED or signaling contact). Refer to the description of the LED displays in section 5.7.1.

5.7.2.1 Error display of the System LED

See description of the LED displays in section 5.7.1.

5.7.2.2 Error display on CH1 / CH0

Check whether

- the DIL switch S0 (CH1) or S8 (CH0) is in position 1, when the OLM is in the electrical star segment of a star topology (see section 3.2)
- the problem remains after removing the RS-485 connector.

Still there: Device defective⁵. Change the OLM.

Gone: The error is in the RS-485 bus segment.

Check:

- all RS-485 connectors as described in section 5.3
- the setup and the shielding of the RS-485 bus segment.
- the RS-485 bus segment using the PROFIBUS bus monitor
- the configuration of all bus nodes.

5.7.2.3 Error display on CH2 / CH3

1. Check whether

- only modules of the same type are connected to each other optically (see chapter 3),
- the optical fiber is permitted for the module type being used and does not exceed the permitted length (see Table 2-1).
- the optical channels connected via fiber-optic cables are set to the same mode. (see section 4.2.3)
- the ends of the fiber-optic cables and the optical transmission and receiving components are clean
- the fiber-optic cable connectors are connected completely and correctly,
- the requirements of section 5.1.2 were met when connecting and laying the optical bus cables.

2. Detect the optical receive level (section 5.6):

- Check the fiber-optic cable attenuation with an optical level meter if the level is in the range “function not guaranteed” or “optical link power margin reduced”. If the attenuation is too high, replace the fiber-optic cable. If the attenuation is within the valid range, one of the two OLMs of the disturbed segment is defective. First, replace the OLM which supplies the signal for the measurement mentioned above. If the problem remains, replace the other OLM instead. If there is no optical level meter at hand, you can still get an idea of where the problem lies simply by swapping over **both** fiber-optic cables at **both** OLMs: if the problem moves along with the cables, the cable is almost certainly faulty, if it does not, the problem is in one of the OLMs.
- If the level is in the range “normal operation”, first check the transmitting OLM, as described above, and then the receiving OLM, if necessary.

⁵ Does not apply if the monomaster of a PROFIBUS network is connected to the RS-485 bus segment to be tested. In this case, swap the suspect OLM with another OLM from the network and then carry out the test mentioned above.

If the error moves with the OLM, the device is defective. Replace the OLM.

If the error does not move with the OLM, the disturbance originates in the RS-485 bus segment. Take measures as described above.

- If the level of **both** OLMs of the disturbed fiber-optic cable segments is within the range “optical link power margin reduced” or “normal operation”, one of the two OLMs of the disturbed fiber-optic cable segment is defective. In this case replace one OLM of the disturbed fiber-optic cable segment first. If the error persists, replace the other OLM instead.

5.7.2.4 Level display lit yellow or red

For active interfaces see previous section 5.7.2.3.

The level display cannot normally be deactivated. If you want to have the (correctly) displayed red level of an unused optical interface changed to green, a "short circuit" must be arranged from the transmitter to the receiver of the channel involved using a suitable fiber-optic cable. At the same time, the monitoring for this channel must be active. This means for channel 2, the S1 and S2 switches are turned off and for channel 3, the S3 and S4 switches. The channel display (yellow LED) remains off and the corresponding level LED is green.

5.8 Maintenance

The OLMs V4.0 are maintenance-free. It is also not possible to make any calibrations on the OLM V4.0. There are no elements whatsoever inside the OLM V4.0 housing that need to be touched by engineers or users. The only controls are the DIL switches are accessible from the outside.

The devices have a resettable fuse (PTC). **If the fuse trips (all LEDs go off despite correctly applied power supply), the device should be disconnected from the power supply for approximately 30 minutes before it can be turned on again.**

If solvents or similar chemicals are used in the vicinity, the user should periodically inspect the visible plastic parts of the OLM V4.0 (DIL switches). If there are any signs of changes, the OLM V4.0 should be replaced.

If any other fault develops, please send the device to your SIEMENS service center for repair. Repairs on-site are not possible.

5.9 Cleaning

If it becomes necessary to clean the device, this must be done with a dry, lint-free cloth. Do not use water or solvent! If liquids get into the device, it must be deactivated.

When cleaning the device, make sure that no dirt enters the optical transmission path or gets onto the optical components. This means either that the fiber-optic cables remain connected or you fit the supplied protective caps!

5.10 Configuration

Because of frame delays due to cables, network components and monitoring mechanisms in the network components, the PROFIBUS network parameter "slot time" must be adapted to the network span, the network topology and the data rate when configuring the network.

5.10.1 Configuring optical bus and star topologies

You configure the PROFIBUS network, for example with SIMATIC STEP 7 (V5) or COM PROFIBUS (V5). You enter the number of OLMs and overall cable length in a configuration dialog. The configuration tools then check whether the slot time can be retained in the chosen communication profile. If the limit is exceeded due to the extra delays caused by OLMs and fiber-optic cables, a warning message is displayed and the parameters are adapted.

5.10.2 Configuring redundant optical rings

The following configuration requirements must be met in the redundant optical ring (see section 3.3 for details):

- One unused address lower than the HSA (1)
- Increase of the retry value to at least 3 (2)
- Checking and adaptation of the slot time (3)

Use the user-specific profile of the configuration tool to set the parameters under (2) and (3). Calculate the slot time based on the following equation:

$$\text{Slot time} = a + (b * \text{Length}_{\text{FOC}}) + (c * \text{Number}_{\text{OLM}})$$

Slot time is the monitoring time in bit times

Length_{FOC} is the sum of all fiber-optic cables (segment lengths) in the network.
The length must be entered in km!

Number_{OLM} is the number of the PROFIBUS OLMs in the network.

The factors a, b and c depend on the transmission speed and can be found in the following table:

Data rate	a	b	c
12 Mbps ⁶	1651	240	28
6 Mbps ¹	951	120	24
3 Mbps ¹	551	60	24
1.5 Mbps ¹	351	30	24
500 Kbps	251	10	24
187.5 Kbps	171	3.75	24
93.75 Kbps	171	1.875	24
45.45 Kbps	851	0,909	24
19.2 Kbps	171	0,384	24
9.6 Kbps	171	0,192	24

Table 5-2 Constants for calculating the slot time for DP-standard (redundant optical ring)

Data rate	a	b	c
12 Mbps ¹	1651	240	28
6 Mbps ¹	951	120	24
3 Mbps ¹	551	60	24
1.5 Mbps ¹	2011	30	24
500 Kbps	771	10	24
187.5 Kbps	771	3.75	24
93.75 Kbps	451	1.875	24
45.45 Kbps	851	0.909	24
19.2 Kbps	181	0.384	24
9.6 Kbps	171	0.192	24

Table 5-3 Constants for calculating the slot time for DP/FMS ("universal") and DP with S5 95U (redundant optical ring)

The slot time calculation only takes into account the optical network and the connection of bus nodes to the OLM via a RS-485 bus segment each with a maximum length of 20 m. Longer RS-485 bus segments are included in the calculation by adding them to the length of the fiber-optic cables.

Note:

If the value of the slot time is configured too low, this can lead to malfunctions and error messages on the OLM. The system LED flashes red/green.

⁶ With OLM/G11-1300 and OLM/G12-1300, minimum slot times must be maintained according to the following table at data rates of 12 Mbps, 6 Mbps, 3 Mbps and 1.5 Mbps:

Data rate	Minimum slot time
12 Mbps	3800 t _{Bit}
6 Mbps	2000 t _{Bit}
3 Mbps	1000 t _{Bit}
1.5 Mbps	530 t _{Bit}

If the calculated slot time is shorter than the minimum slot time, use the minimum slot time from the table above as the configured slot time.

6 Approvals and Marks

6.1 CE Mark

Product name SIMATIC NET

SIMATIC NET OLM / P11 V4.0	6GK1 503-2CA00
SIMATIC NET OLM / P12 V4.0	6GK1 503-3CA00
SIMATIC NET OLM / P22 V4.0	6GK1 503-4CA00
SIMATIC NET OLM / G11 V4.0	6GK1 503-2CB00
SIMATIC NET OLM / G12 V4.0	6GK1 503-3CB00
SIMATIC NET OLM / G22 V4.0	6GK1 503-4CB00
SIMATIC NET OLM / G12-EEC V4.0	6GK1 503-3CD00
SIMATIC NET OLM / G11-1300 V4.0	6GK1 503-2CC00
SIMATIC NET OLM / G12-1300 V4.0	6GK1 503-3CC00

EMC directive The SIMATIC NET products above meet the requirements for the following EC directives:



Directive 89/336/EEC

“Electromagnetic compatibility“

Area of Application

The products are designed for use in an industrial environment:

Area of Application	Requirements	
	emission	immunity
Industrial area	EN 61000-6-4 : 2001 (replaces EN 50082-2)	EN 61000-6-2 : 2001 (replaces EN 50081-2)
Living and business environment as well as small companies	EN 61000-6-3 : 2001 (replaces EN 50081-1)	EN 61000-6-1 : 2001 (replaces EN 50082-1)

Installation guidelines

The products meet the requirements if you keep to the installation instructions and safety-related notices as described in these instructions and in the “SIMATIC NET PROFIBUS Networks” /1/ manual when installing and operating the device.

Conformity certificates

The EC Declaration of Conformity is available for the responsible authorities according to the above-mentioned EC Directive at the following address:

Siemens Aktiengesellschaft
Industry Sector Industry Automation Division
Industrielle Kommunikation (I IA SC IC)
Postfach 4848
D-90026 Nürnberg, Germany

Notes for the manufacturers of machines

The products are not machines in the sense of the EC Machinery Directive. There is therefore no declaration of conformity relating to the EC Machinery Directive 89/392/EEC for these products.

If the products are part of the equipment of a machine, they must be included in the procedure for the declaration of conformity by the manufacturer of the machine.

General notice concerning the approvals

The listed approvals are valid only when the corresponding marks are shown on the product.

6.2 c-tick

Canada

Canadian Notice: This Class B digital apparatus complies with Canadian ICES-003.

Avis Canadien Cet appareil numérique de la classe B est conforme à la norme NMB-003 du Canada.

Australia



This product meets the requirements of the AS/NZS 3548 standard.

N117

6.3 FM approval



CL.1, DIV.2, GP. A,B,C,D, T4
CL.1, Zone 2, GP. IIC, T4
Ta: -25°C...+60°C (model OLM/G12 ECC, only)
Ta: 0°C...+60°C (all other models)

6.4 Ex approval

Models: OLM / P11 V4.0, OLM / P12 V4.0, OLM / P22 V4.0, OLM / G11 V4.0, OLM / G12 V4.0,
OLM / G22 V4.0, OLM / G12-EEC V4.0



II 3G (2)G
Ex nA [op is] IIC T4
KEMA 09 ATEX 0173 X
EN 60079-15:2005
EN 60079-0:2006
EN 60079-28:2007

Models: OLM/G11-1300 V4.0, OLM/G12-1300 V4.0



II 3G
Ex nA II T4
KEMA 08 ATEX 0003 X
EN 60079-15:2005
EN 60079-0:2006

6.5 UL approval (U.S. and Canada)



c(UL)us LISTED
IND. CONT. EQ.: 91MA
I.T.E.for HAZ. LOC.: 34SM
CLASS 1, DIV. 2 GROUP A; B; C; D T4
CLASS 1, Zone2, GP. IIC, T4
CLASS 1, Zone2, Aex nC IIC, T4



WARNING - Exposure to some chemicals may degrade the sealing properties of materials used in the following devices:

Relay K600 – materials used

Manufacturer 1, Song Chuan:

base:	PA66
dust cover:	PBT
sealing compound:	Eccobond (Emerson & Cuming)

Manufacturer 2, Hongfa:

base, dust cover, card:	PBT 3316 (E213445);
sealing compound:	6060RP (Well-Ta Chemical Company Limited)

6.6 Shipbuilding approvals

The devices of the OLM V4.0 series also meet several requirements for shipbuilding. For the respectively valid approvals call our hotline +49-18050500222.

Furthermore you can gather information at:

<http://support.automation.siemens.com>

7 References

7.1 References

Sources of information and other documentation

1. SIMATIC NET PROFIBUS networks
order numbers:
6GK1970-5CA20-0AA0 German
6GK1970-5CA20-0AA1 English
6GK1970-5CA20-0AA2 French
6GK1970-5CA20-0AA4 Italian
2. EN 50170-1-2 1996: “General Purpose Field Communication System“, Volume 2
“Physical Layer Specification and Service Definition“
3. DIN 19245: “Measurement and Control; PROFIBUS Part 3; Process Field Bus;
Decentralized Peripherals (DP)”
4. EIA Standard RS-485 (April 1983): “Standard for electrical characteristics of generators“

Glossary

BFOC	Bayonet Fiber Optic Connector
DIN	Deutsche Industrie Norm [German industrial standard]
EEC	Extended Environmental Conditions
EIA	Electronic Industries Association
EN	European standard
EMC	Electromagnetic Compatibility
HCS™	Hard Polymer Cladded Silica Fiber (registered trademark of Ensign-Bickford)
HSA	Highest Station Address
IEC	International Electrotechnical Commission
LED	Light Emitting Diode
OBT	Optical Bus Terminal
OLM	Optical Link Module
PCF	Polymer Cladded Fiber (similar to HCS™)
PNO	PROFIBUS User Organization
SELV	Safety Extra Low Voltage
TSDR MIN	Time Station Delay Remote Minimum
UL	Underwriter Laboratories
VDE	Verein Deutscher Elektroingenieure (Association of German Electrical Engineers)

Index

A

ATEX, 47

C

CE mark, 45
Compatibility, 22
C-tick mark, 46

D

DIL switch, 22

E

Electromagnetic compatibility, 27

F

FM approval, 47
Fuse, 41

I

Installation options, 31

L

Link power margin, 29

M

Mode, 22

N

Network topology
 bus (linear) topology, 7

point-to-point-connection, 7
redundant optical ring, 7
ring topology, 12
star topology, 7, 10

O

Optical link power budget, 29
Optical star topology, 3

R

Redundant ring, 12

S

Segment monitoring, 23, 24
Shielded cables, 28
SINEC L2FO, 22

U

UL approval, 47