



DIGITAL MONITORING RELAY FOR THREE-PHASE LINE VOLTAGE REVERSIBLE PHASE SEQUENCE PHASE FAILURE 3X 160 TO 690V AC 50 TO 60 HZ UNDERVOLT. AND OVERVOLT. 160-690V HYSTERESIS 1-20V 0-20S EACH FOR UMIN AND UMAX 1 W FOR UMIN 1W FOR UMAX SCREW TERMINAL REPLACEMENT PRODUCT F. 3UG3041-1BP50

Product function	Phase monitoring relay
-------------------------	------------------------

Measuring circuit:

Type of current / for monitoring		AC
Number of poles / for main current circuit		3
Measurable voltage		
• for AC	V	160 ... 690
Adjustable voltage range	V	160 ... 690
Adjustable response delay time		
• with lower or upper limit violation	s	0.1 ... 20
Relative adjustment accuracy	%	0.2
Relative metering precision	%	5
Precision of digital display		+/-1 digit
Relative repeat accuracy	%	1

General technical details:

Design of the display		LCD
Type of display / LED		No
Product function		
• undervoltage recognition		Yes
• overvoltage recognition		Yes
• phase sequence recognition		Yes

<ul style="list-style-type: none"> • phase disturbance recognition • asymmetry recognition • overvoltage recognition of 3 phases • undervoltage recognition of 3 phases • tension window recognition of 3 phases • self-reset • open-circuit or closed-circuit current principle 		Yes
Starting time / after the control supply voltage has been applied	ms	1,000
Response time / maximum	ms	450
Voltage type / of control feed voltage		AC
Control supply voltage		
<ul style="list-style-type: none"> • at 50 Hz / at AC <ul style="list-style-type: none"> • rated value • at 60 Hz / at AC <ul style="list-style-type: none"> • rated value 	V	160 ... 690
	V	160 ... 690
Operating range factor control supply voltage rated value		
<ul style="list-style-type: none"> • at 50 Hz <ul style="list-style-type: none"> • for AC • at 60 Hz <ul style="list-style-type: none"> • for AC 		1 ... 1
		1 ... 1
Impulse voltage resistance / rated value	kV	6
Recorded real power	W	2
Protection class IP		IP20
Electromagnetic compatibility		IEC 60947-1 / IEC 61000-6-2 / IEC 61000-6-4
Resistance against vibration / according to IEC 60068-2-6		1 ... 6 Hz: 15 mm, 6 ... 500 Hz: 2g
Resistance against shock / according to IEC 60068-2-27		sinusoidal half-wave 15g / 11 ms
Installation altitude / at a height over sea level / maximum	m	2,000
Conductor-bound parasitic coupling BURST / according to IEC 61000-4-4		2 kV
Conductor-bound parasitic coupling conductor-earth SURGE / according to IEC 61000-4-5		2 kV
Conductor-bound parasitic coupling conductor-conductor SURGE / according to IEC 61000-4-5		1 kV
Electrostatic discharge / according to IEC 61000-4-2		6 kV contact discharge / 8 kV air discharge
Field-bound parasitic coupling / according to IEC 61000-4-3		10 V/m
Insulation voltage / for overvoltage category III according to IEC 60664 / with degree of pollution 3 / rated value	V	690
Degree of pollution		3
Ambient temperature		
<ul style="list-style-type: none"> • during operating • during storage 	°C	-25 ... +60
	°C	-40 ... +85

• during transport	°C	-40 ... +85
Galvanic isolation		
• between entrance and outlet		Yes
• between the outputs		Yes
• between the voltage supply and other circuits		Yes







Mechanical design:		
Width	mm	22.5
Height	mm	92
Depth	mm	91
mounting position		any
Distance, to be maintained, to earthed part		
• forwards	mm	0
• backwards	mm	0
• sideways	mm	0
• upwards	mm	0
• downwards	mm	0
Distance, to be maintained, to the ranks assembly		
• forwards	mm	0
• backwards	mm	0
• sideways	mm	0
• upwards	mm	0
• downwards	mm	0
Distance, to be maintained, conductive elements		
• forwards	mm	0
• backwards	mm	0
• sideways	mm	0
• upwards	mm	0
• downwards	mm	0
Mounting type		snap-on mounting
Product function / removable terminal for auxiliary and control circuit		Yes
Design of the electrical connection		screw-type terminals
Type of the connectable conductor cross-sections		
• solid		1x (0.5 ... 4 mm ²), 2x (0.5 ... 2.5 mm ²)
• finely stranded		
• with wire end processing		1x (0.5 ... 2.5 mm ²), 2x (0.5 ... 1.5 mm ²)
• for AWG conductors		
• solid		2x (20 ... 14)
• stranded		2x (20 ... 14)

Tightening torque		
• with screw-type terminals	N·m	0.8 ... 1.2

Outputs:

Number of NO contacts / delayed switching		0
Number of NC contacts / delayed switching		0
Number of change-over switches / delayed switching		2
Current carrying capacity / of output relay		
• at AC-15		
• at 250 V / at 50/60 Hz	A	3
• at 400 V / at 50/60 Hz	A	3
• at DC-13		
• at 24 V	A	1
• at 125 V	A	0.2
• at 250 V	A	0.1
Thermal current / of the contact-affected switching element / maximum	A	5
Operating current / at 17 V / minimum	mA	5
Continuous current / of the DIAZED fuse link of the output relay	A	4
Mechanical operating cycles as operating time / typical		10,000,000
Electrical operating cycles as operating time / at AC-15 / at 230 V / typical		100,000
Operating cycles / with 3RT2 contactor / maximum	1/h	5,000

Certificates/approvals:

General Product Approval	EMC	Test Certificates		
 CCC	 UL	 C-TICK	Special Test Certificate	Type Test Certificates/Test Report
Shipping Approval	other			
 DNV	 GL	 LRS	Declaration of Conformity	other

Further information:

Information- and Downloadcenter (Catalogs, Brochures,...)
<http://www.siemens.com/industrial-controls/catalogs>

Industry Mall (Online ordering system)
<http://www.siemens.com/industrial-controls/mall>

Cax online generator:
<http://www.siemens.com/cax>

Service&Support (Manuals, Certificates, Characteristics, FAQs,...)
<http://support.automation.siemens.com/WW/view/en/3UG4615-1CR20/all>

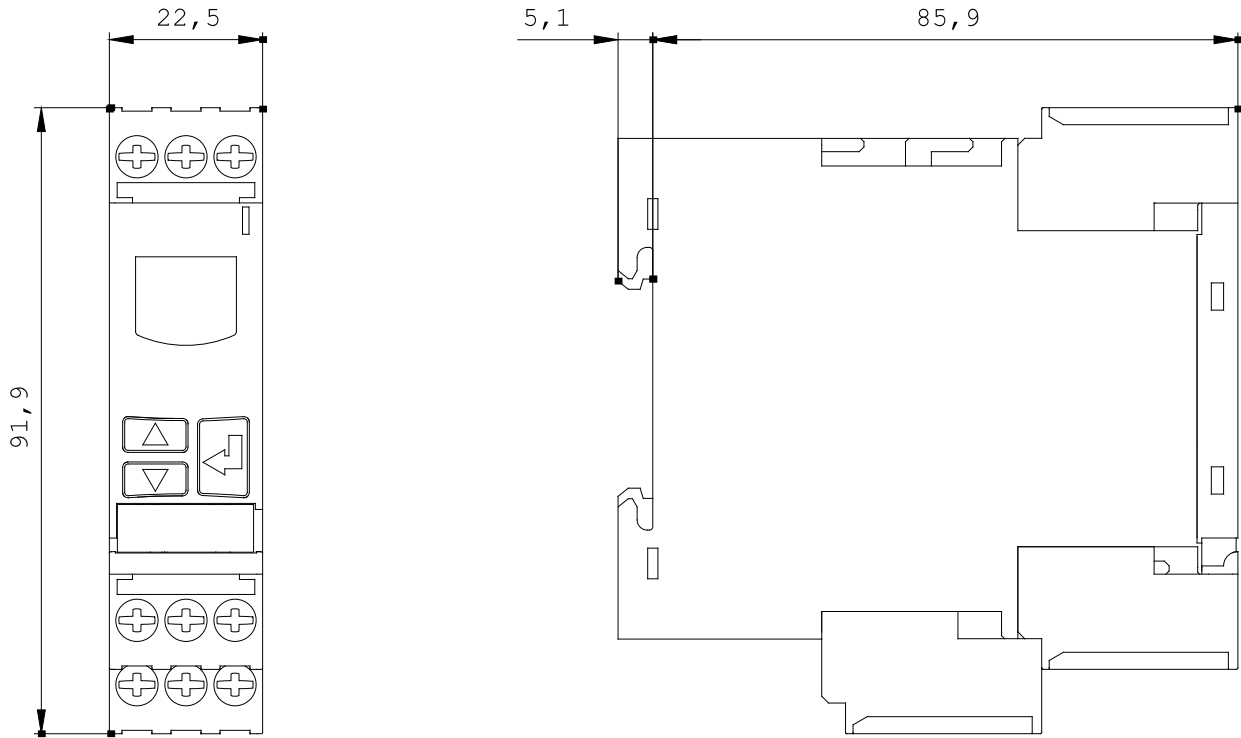

last change: Aug 5, 2014

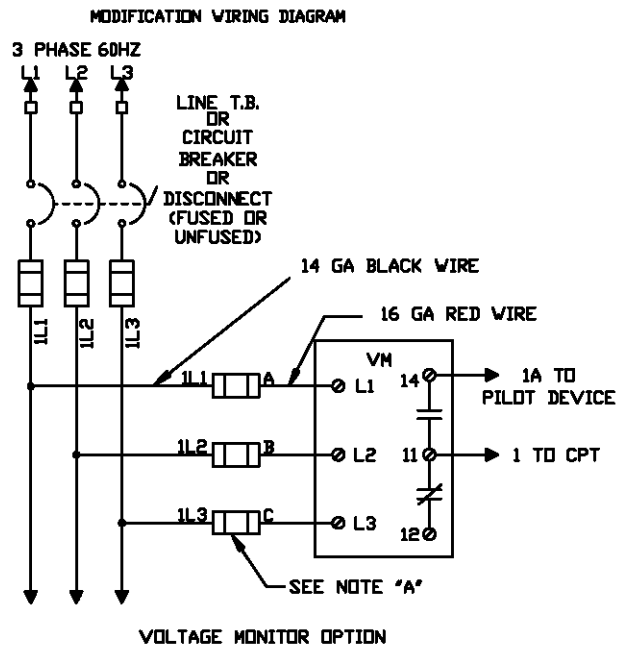

NOTES:

- A. THE NUMBERING OF FUSES SHOWN SHALL FOLLOW SEQUENTIALLY THE NUMBERING OF ANY EXISTING FUSES SHOWN ON THE WIRING DIAGRAM WITH WHICH THIS IS USED.**