

(2X) 316 STAINLESS LOCKABLE SNAP LATCH

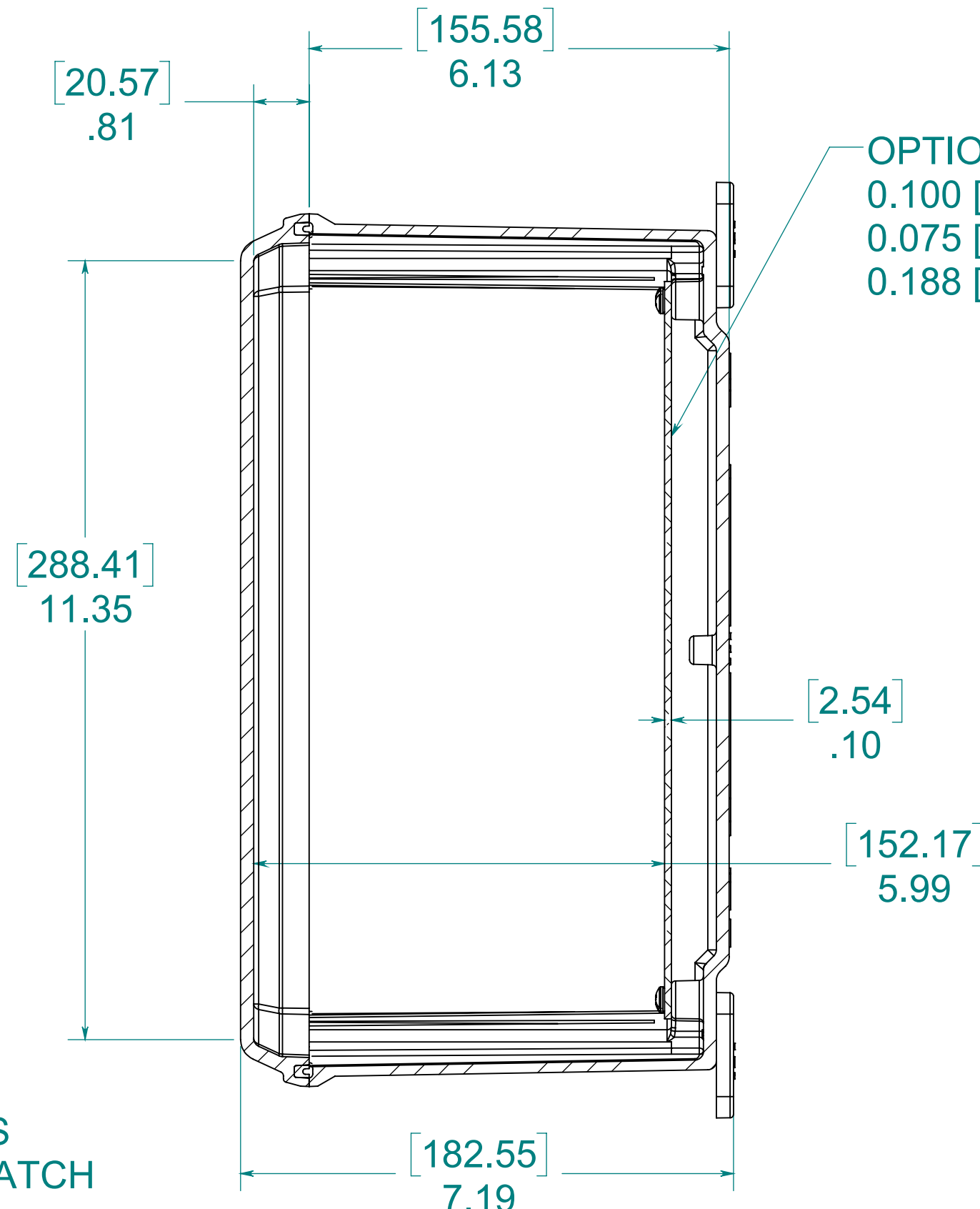

SECTION A-A

OPTIONAL BACK PANEL SHOWN
 0.100 [2.54mm] TH'K- ALUMINUM
 0.075 [1.91mm] TH'K- WHITE STEEL
 0.188 [4.78mm] TH'K- PVC

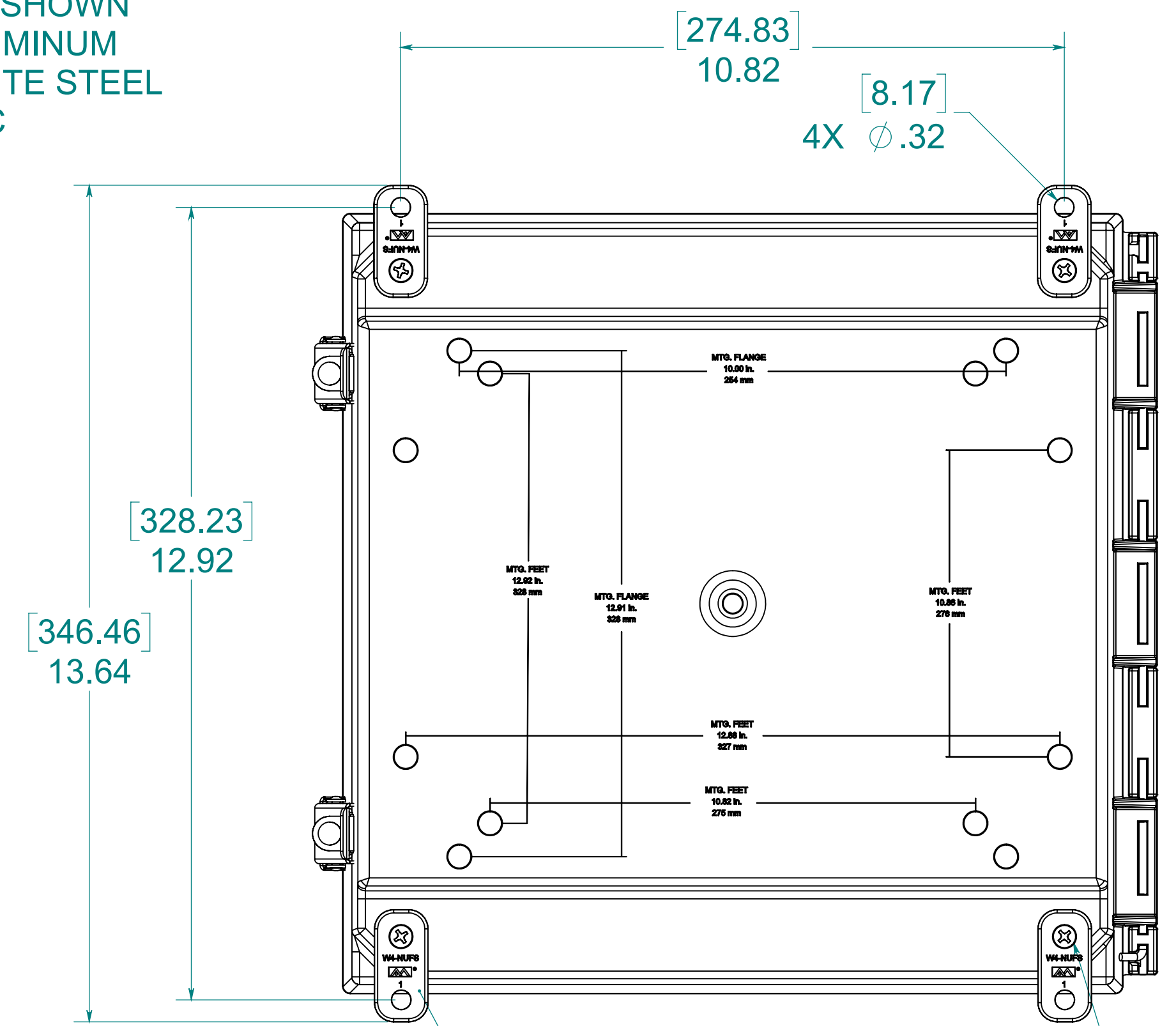

(4X) POLYCARBONATE FEET

(4X) EACH #10-32 BRASS INSERTS AND 316 STAINLESS STEEL FEET SCREWS

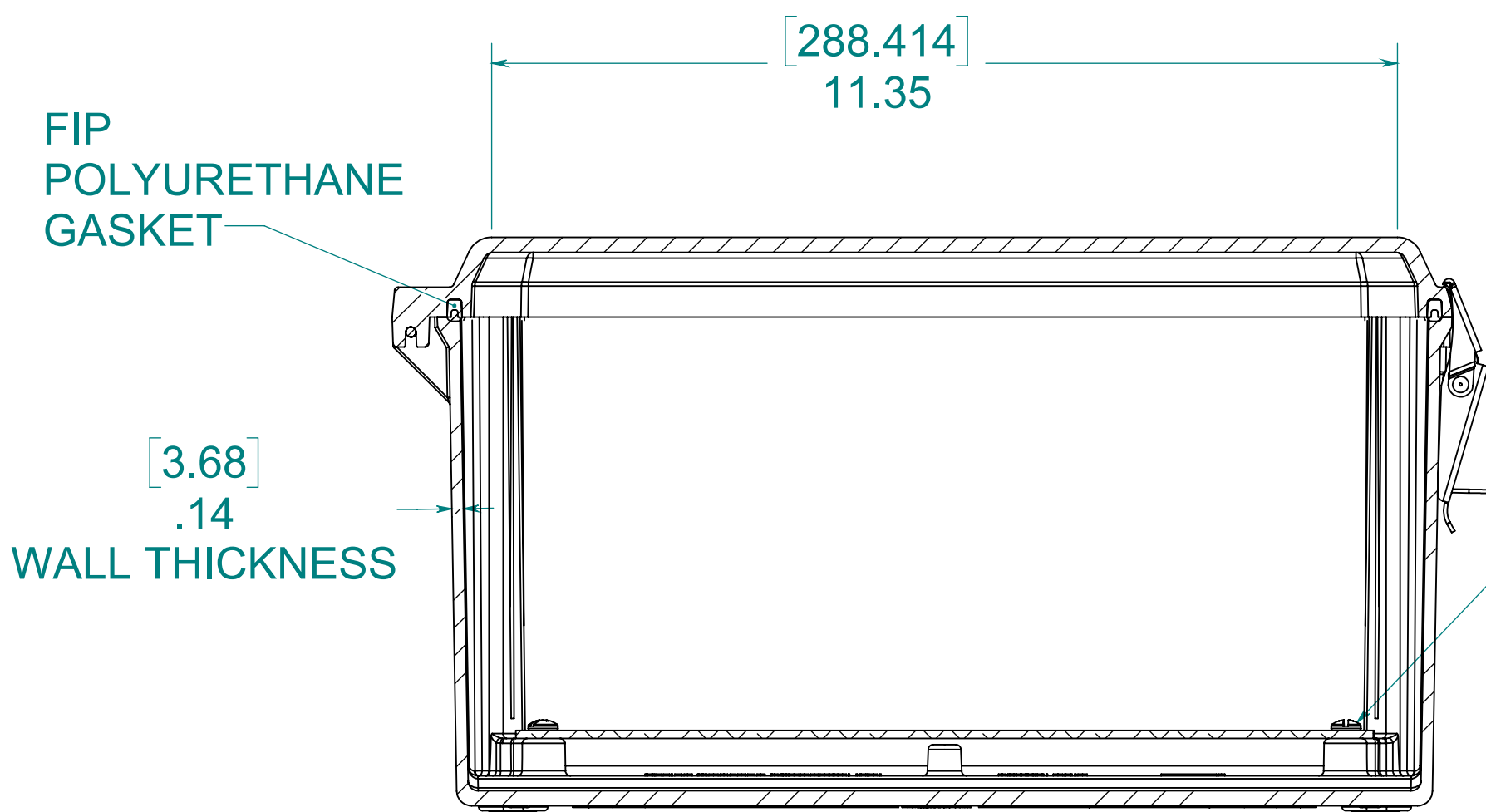

SECTION B-B

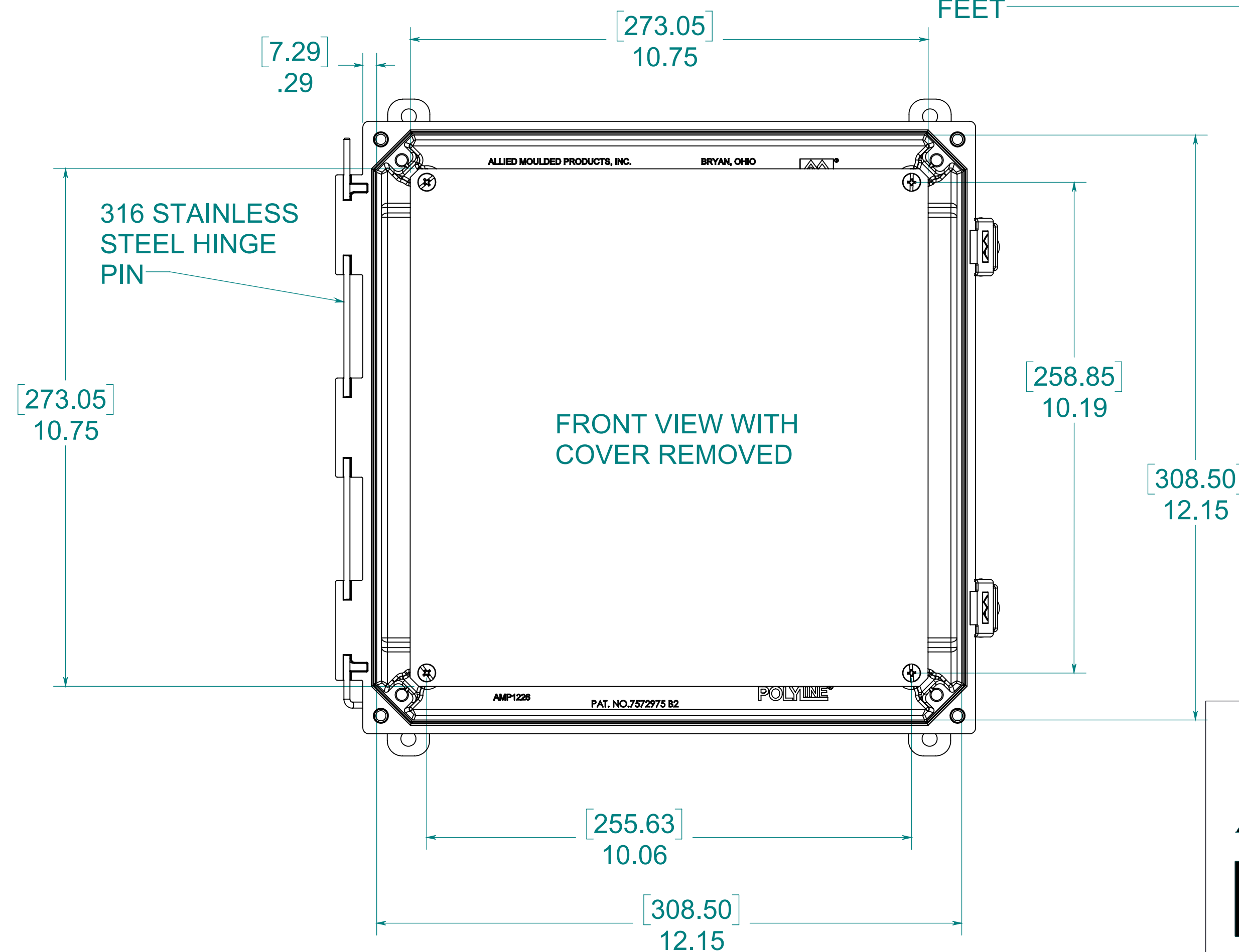

FRONT VIEW WITH COVER REMOVED

316 STAINLESS STEEL HINGE PIN

(4X) EACH #10-32 BRASS INSERTS AND PLATED CARBON STEEL SCREWS

MATERIAL:
 BOX- INJECTED POLYCARBONATE
 STANDARD COVER- INJECTED POLYCARBONATE
 CLEAR COVER- INJECTED POLYCARBONATE

NOTE:
 1. DATA SUBJECT TO CHANGE WITHOUT NOTICE

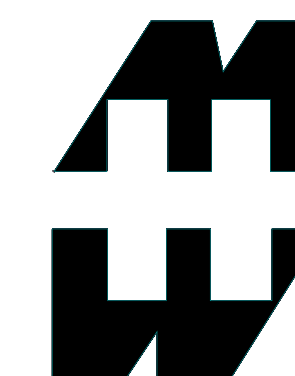

PART No. PCJ12126L

for more information visit www.hammfg.com
 Data subject to change without notice

Drawing Not to Scale