

OPTIONAL BACK PANEL  
0.100 [2.54] TH'K- ALUMINUM  
0.075 [1.91] TH'K- WHITE STEEL & GALVANNEALED  
0.125 [3.18] TH'K- FIBERGLASS

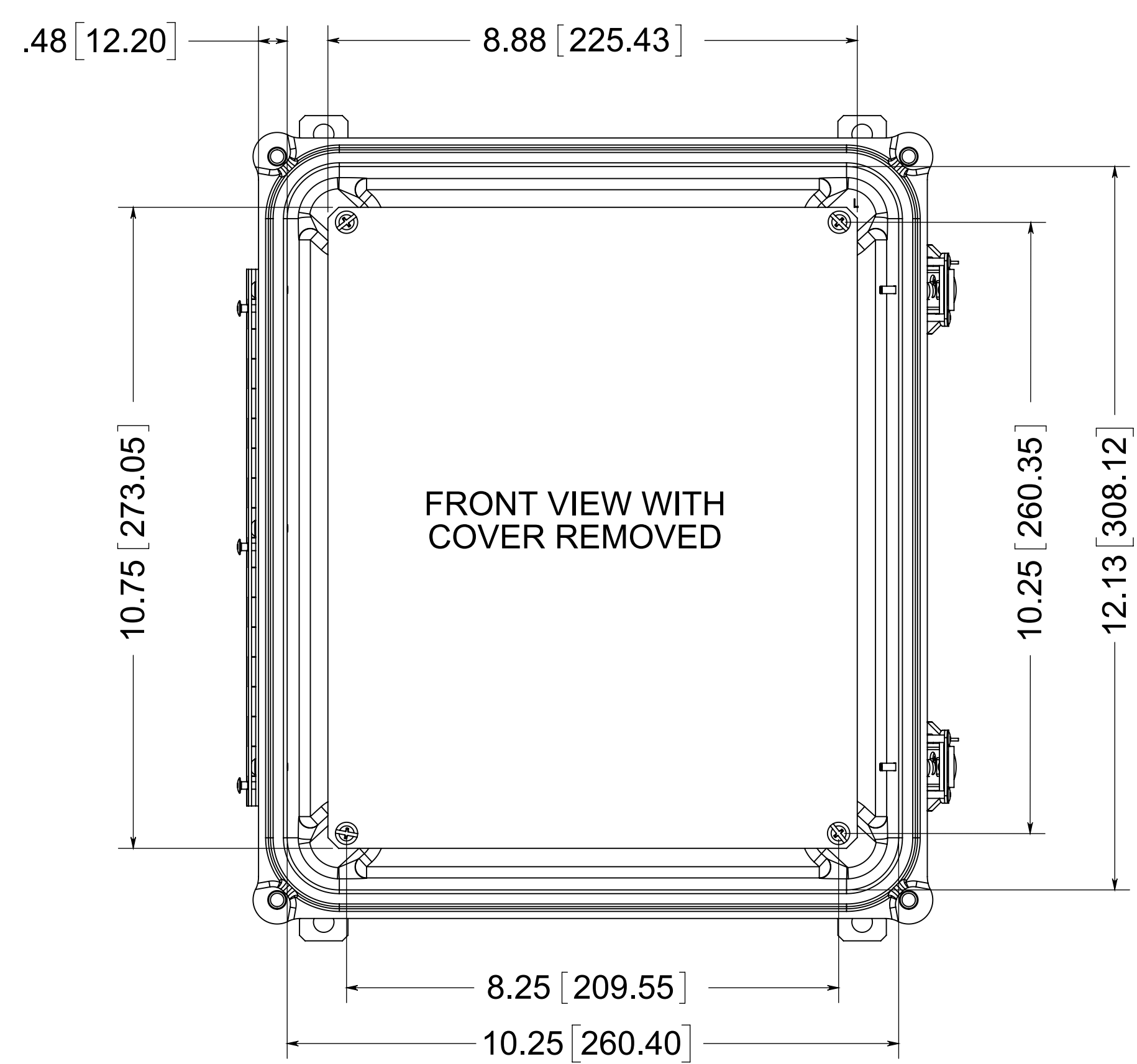
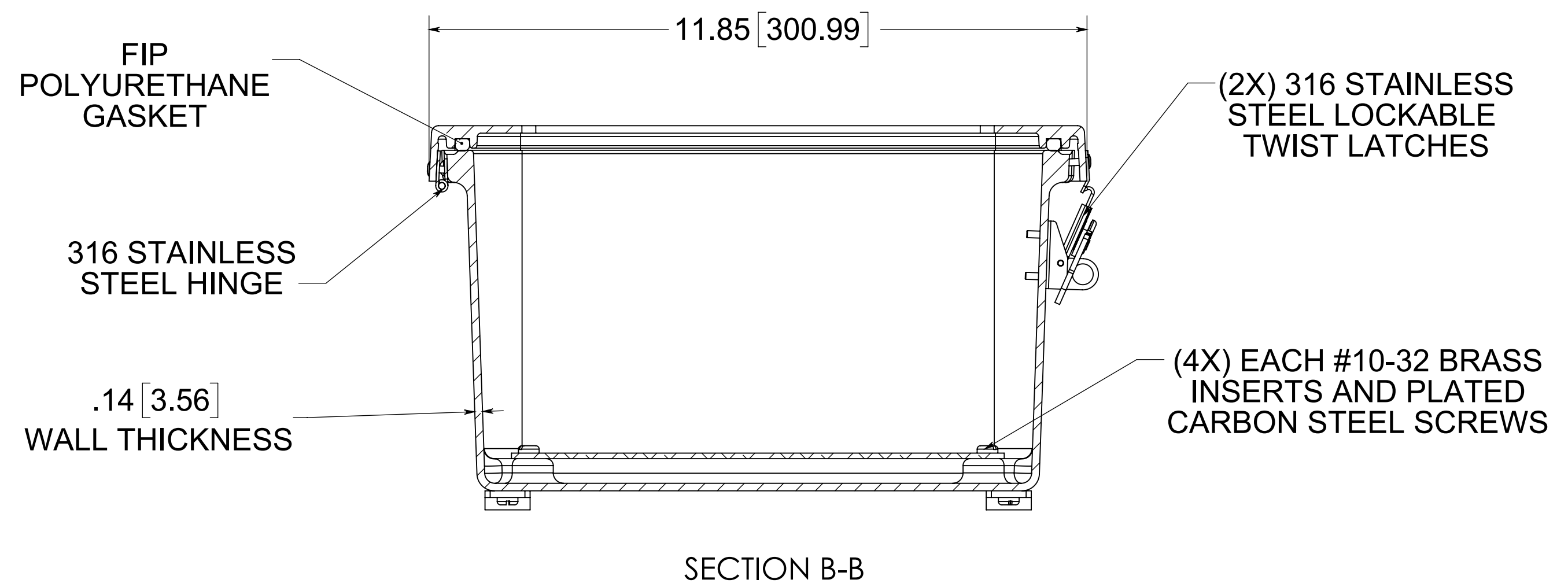
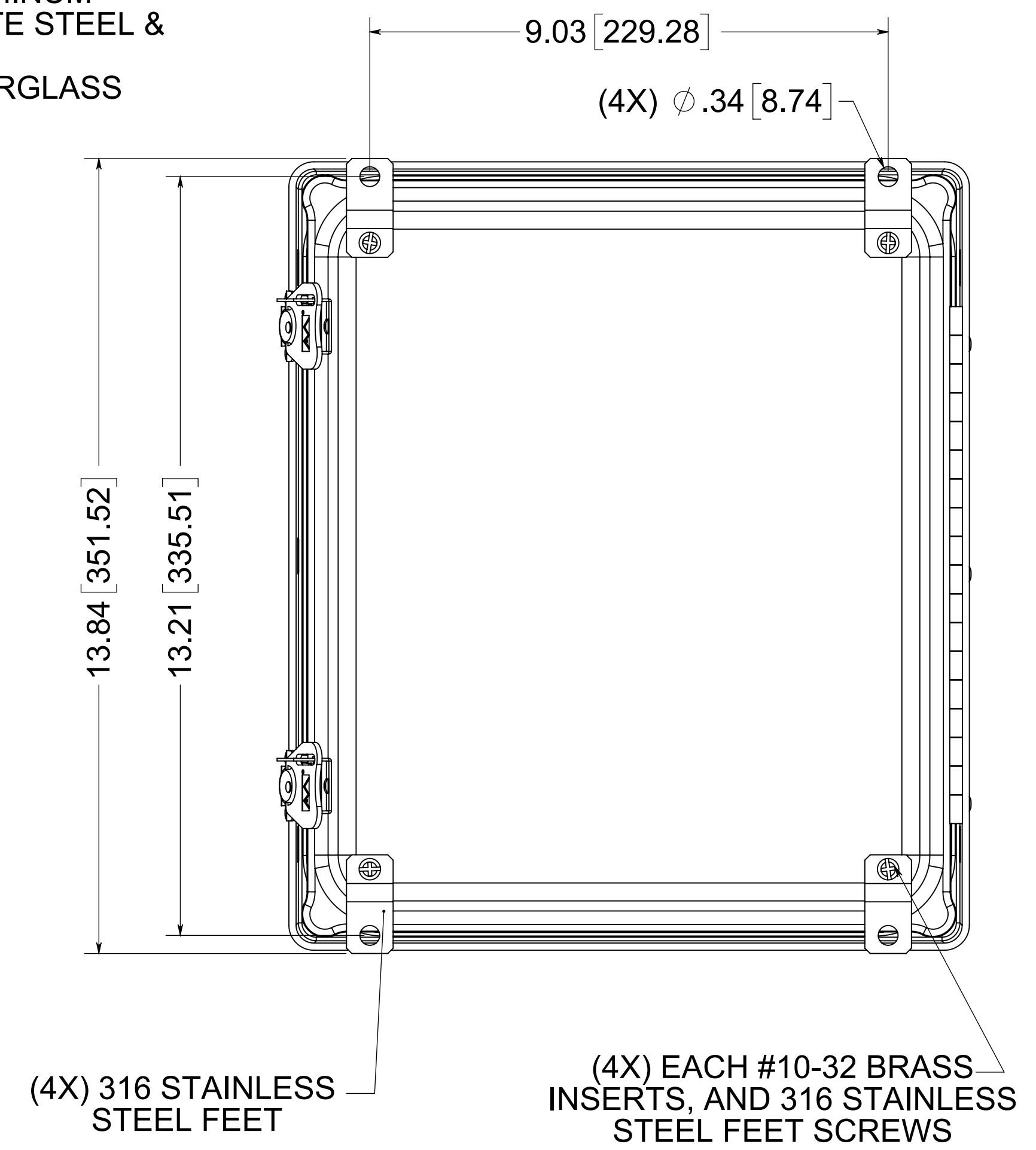

MATERIAL  
BOX- COMPRESSION MOLDED FIBERGLASS REINFORCED POLYESTER  
COVER- COMPRESSION MOLDED FIBERGLASS REINFORCED POLYESTER  
WINDOWS- POLYCARBONATE

NOTES:  
1. DATA SUBJECT TO CHANGE WITHOUT NOTICE

**PART No. PJ12106TW**  
for more information visit  
[www.hammfg.com](http://www.hammfg.com)  
Data subject to change without notice  
Drawing Not to Scale