

ORDERING INFORMATION

Order code: 10057
 Description: BMH1000/QUADTAP/C/CWA/H/K/STD
 UPC: 69549100572

SPECIFICATIONS

Ballast type: Magnetic metal halide
 Ballast style: Core and coil
 Circuit type: CWA
 ANSI code: M47
 Input voltage (V): 120/208/240/277
 Input frequency (Hz): 60
 Line volt regulation: $\pm 10\%$
 Line watt regulation: $\pm 10\%$
 Insulation class: H (180°)

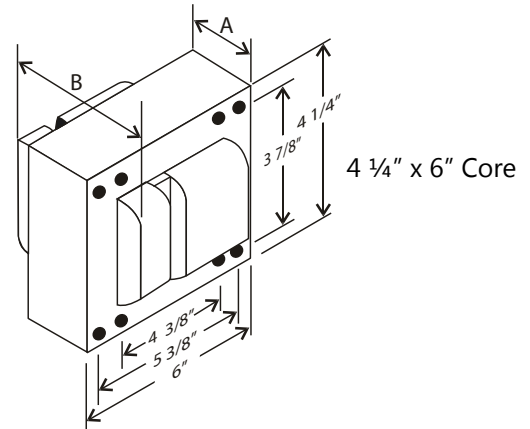

Input voltage (V)	Operating current (A)	Open circuit current (A)	Starting current (A)	Rated lamp watts (W)	Input watts (W)	OCV (V)	Dropout voltage (V)	UL 1029 code	Fuse rating (A)	Input current (A)	Power factor	Starting temperature
120	9.00	5.40	6.60	1 000	1 080	421	60	C	20	5.70 - 7.30	0.90	-20°F / -30°C
208	5.20	3.30	3.80	1 000	1 080	421	104	C	15	3.25 - 4.30	0.90	-20°F / -30°C
240	4.50	2.86	3.3	1 000	1 080	421	120	C	10	2.80 - 3.70	0.90	-20°F / -30°C
277	3.90	2.50	2.90	1 000	1 080	421	140	C	10	2.45 - 3.20	0.90	-20°F / -30°C

HIGH POTENTIAL TEST (V)

1 minute:	2 000
2 seconds:	2 500
OCV test:	390 - 460
Short circuit:	5.30 - 6.20

BALLAST DIMENSIONS

Dimension A:	2.80"
Dimension B:	4.90"
Lead Lengths:	12.00"
Weight (lbs):	21.50

WIRING DIAGRAM

Ground ballast core

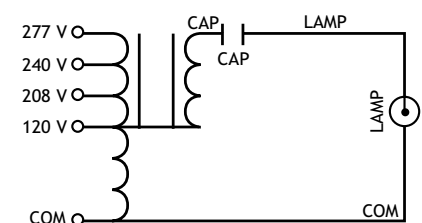

BRACKET

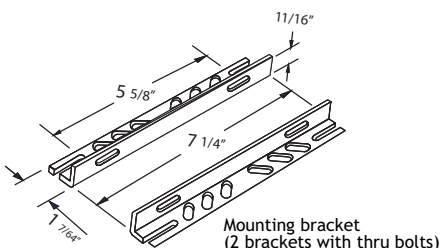

CAPACITOR

