

table of contents

industrial fans

bronze series

silver series

gold series

platinum series

control matrix

controls & accessories

fan guard instructions

planning your fan efficiency



enviro green

Commercial Duty

Bronze Line

All Bronze Line HD commercial fans are completely coated with corrosion resistant epoxy

save

up to
50% of your cooling cost
30% of your heating cost

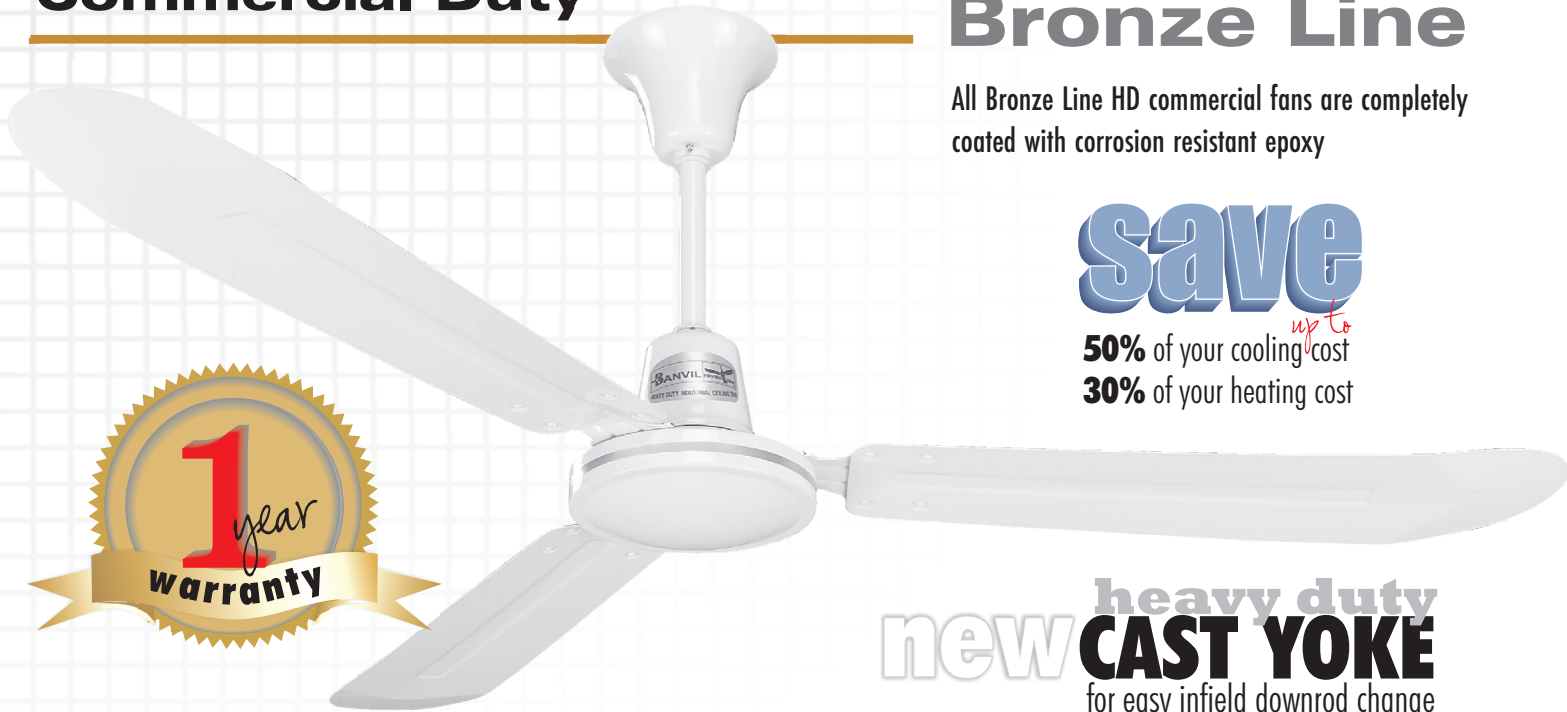

new heavy duty CAST YOKE
 for easy infield downrod change

Model	FP36	FP36R	FP48#	FP48R#	FP56	FP56-36**	FP56R	FP56R-36**
Safety Cable	60"	60"	60"	60"	60"	60"	60"	60"
Cord/Lead Wire	60"	60"	60"	60"	60"	60"	60"	60"
Diameter Sweep	36"	36"	48"	48"	56"	56"	56"	56"
CFM	10,500	10,500	18,000	18,000	22,000	22,000	22,000	22,000
Area (sq.ft.)	700	700	1,400	1,400	1,700	1,700	1,700	1,700
Velocity (ft/m)	600	600	600	600	600	600	600	600
Volts	120	120	120	120	120	120	120	120
Amps	0.35	0.35	0.50	0.50	0.55	0.55	0.55	0.55
Watts	40	40	50	50	65	65	65	65
RPM (max)	360	360	320	320	280	280	280	280
Wiring	plug-in	3+ground	plug-in	3+ground	plug-in	plug-in	3+ground	3+ground
Airflow	down only	up & down	down only	up & down	down only	down only	up & down	up & down
Weight	9 lbs	9 lbs	11 lbs	11 lbs	13 lbs	13 lbs	13 lbs	14 lbs



ideal for commercial use

**with 36" downrod

#48" have straight blades

Bronze

- Downrod: diameter 7/8" length 10" / FP56-36 & FP36R-36 have downrod length 36"
- Corrosion-resistant epoxy prime and finish coat on all metal housing & blades
- Aerodynamically curved-tip blade results in maximum air delivery. # FP48 & FP48R have straight blades
- All metal, no plastic.
- Permanent lubricated sealed TPI ball bearings.
- Totally enclosed impedance protected motor. Non-polar, extra heavy duty capacitor.
- Use solid state infinite speed motor controls or church quiet control (WC103)
- Heavy cast yoke for easy infield downrod change.
- Customized downrod lengths over 36" available.
 Also 16' cord with plug part# Cord-Wh16.
- For church quiet control use WC103 Control for one fan only

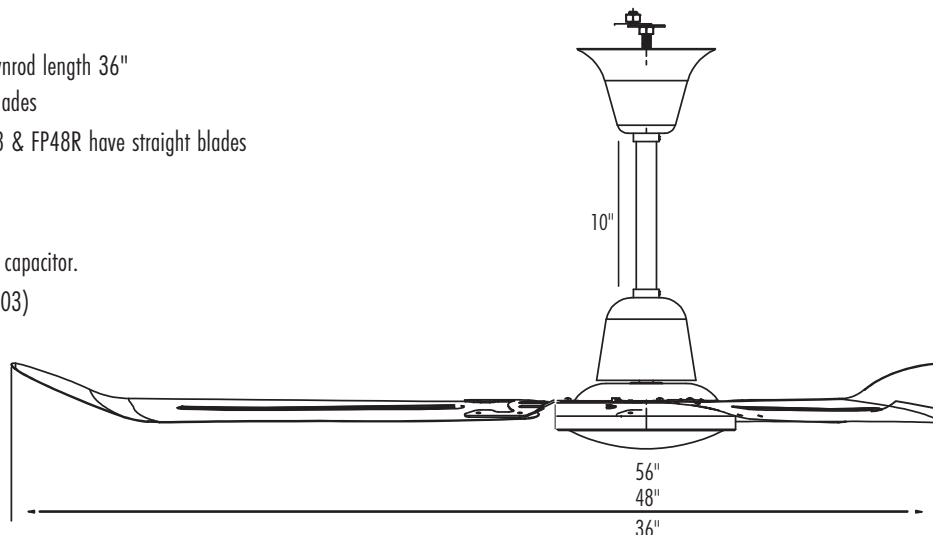

Heavy Duty Industrial

Silver Line

All Silver Line HD industrial fans are complete with corrosion resistant epoxy-coated metal blades.

save

up to
50% of your cooling cost
30% of your heating cost

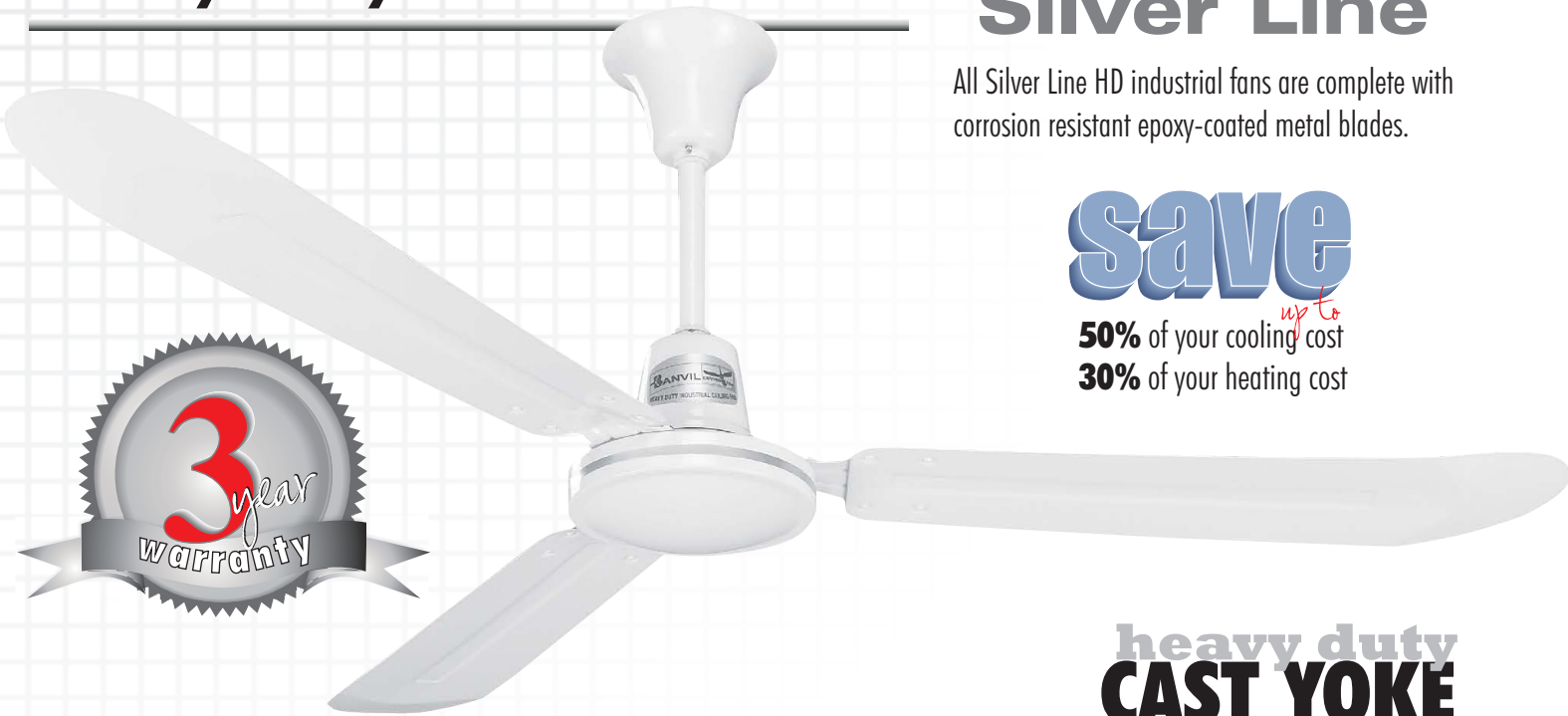

heavy duty
CAST YOKE

Silver features

- Downrod: diameter 7/8" Length: 10"
- Corrosion-resistant epoxy prime and finish coat on all metal housing & blades
 The aerodynamically curved-tip blade results in maximum air delivery.
- All metal, no plastic.
- Permanent lubricated sealed TPI ball bearings.
- Totally enclosed impedance protected motor.
- Non-polar, weatherproof encapsulated, extra heavy-duty capacitor.
- Use solid state infinite speed motor controls or church quiet control. (WC103)
- Heavy cast yoke for easy infield downrod change.
- Customized downrod lengths over 36" available.
 Also 16' cord with plug, (CORD-WH16)

Model	60F9-10	60F7-10
Safety Cable	60"	60"
Cord/Lead Wire	60"	60"
Diameter Sweep	56"	56"
CFM	27,500	27,500
Area (sq.ft.)	1,800	1,800
Velocity (ft/m)	600	600
Volts	120	120
Amps	0.70	0.70
Watts	75	75
RPM (max)	320	320
Wiring	3+ground	plug-in
Airflow	up & down	down only
Weight	13 lbs	13 lbs

Silver



ideal

for heavy duty industrial use

heavy duty motor application
 more airflow - higher RPM's
 higher performance heavy duty fan

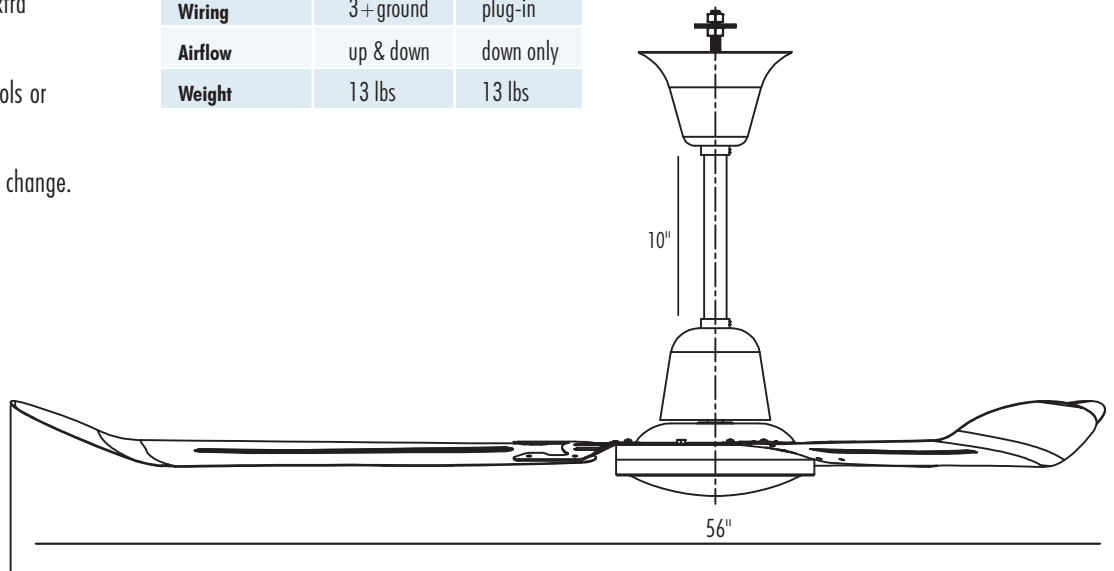

Silver Line features curve tip blades.