

DH1 HVAC/R Drive



Contents

Description	Page
PowerXL DH1 Series Drives	
Standards and Certifications	V6-T2-176
Catalog Number Selection	V6-T2-176
Product Selection	V6-T2-177
Accessories	V6-T2-180
Replacement Parts	V6-T2-186
Technical Data and Specifications	V6-T2-188
Dimensions	V6-T2-194
PowerXL DH1 Series Enclosed Drives	V6-T2-195

PowerXL DH1 Series Drives

Product Description

The DH1 HVAC/R drives are part of Eaton's next generation PowerXL Series of adjustable frequency drives specifically engineered for today's demanding HVAC/R market. The power unit makes use of the most sophisticated semiconductor technology and a highly modular construction that can be flexibly adapted to meet the customer's needs.

The control module was designed to include today's standard HVAC/R communication protocols and I/O while still having the modularity to add additional option cards.

Eaton's patented Active Energy Control is also a standard feature on DH1 drives, offering customers increased efficiency, safety and reliability.

These drives continue the tradition of robust performance and raise the bar on features and functionality, ensuring the best solution at the right price.

Product Range

230 V to 125 hp, 312 A, 90 kW

480 V to 250 hp, 310 A, 160 kW

575 V to 250 hp, 250 A, 187 kW

Features and Benefits

Hardware

- Integrated common mode reduction 5% DC link choke with input surge protection
- Variable torque rated for HVAC/R demands
- 110% variable torque (IL)
- Type 1/IP21 and Type 12/IP54 enclosures available
- Real-time clock—supports calendaring and PLC functionality
- Graphic LCD display and keypad—supports simple menu navigation as well as on-screen diagnostics and troubleshooting
- AUTO operation from keypad and two configurable soft keys
- Conformal coated control and power boards standard

- Control logic can be powered from an external auxiliary control panel—internal drive functions and fieldbus if necessary
- Standard I/O:
 - 8DI, 1DO
 - 2AI, 2AO
 - 2FC, 1FA relays
- Standard communications:
 - BACnet/IP, Modbus TCP, Modbus RTU, BACnet MS/TP
- Two expansion slots—intended to support additional I/O or communication protocols as necessary
- Quick disconnect terminals for I/O connections—supports fast, easy installation

Software

- Active Energy Control—minimizes energy losses in the motor, resulting in industry-leading energy efficiency for your application
- Energy savings calculator
- Quick Start Wizard upon initial power-up supports fast, easy installation
- Standard applications:
 - Standard
 - Multi-PID
 - Advanced
- Copy/paste functionality on drive keypad—allows for fast setup of multiple drives
- Pre-programmed I/O—supports fast, easy installation for most applications
- Dynamic motor regenerative energy management
- Advanced PC Tool with diagnostic capabilities
- Two keypad software keys for easy menu navigation and shortcuts

2.8

Adjustable Frequency Drives

PowerXL DH1 Series Drives

2

Standards and Certifications

Product

- IEC/EN 61800-5-1
- IEC/EN 61800-5-2
- UL 508C
- IEC 61508
- EN 62061
- EN ISO 13849-1

EMC

- Immunity: IEC/EN 61800-3
- Category C2

Certification

- UL
- cUL
- CE
- C-Tick
- RoHS
- Plenum rated



Catalog Number Selection

Catalog Number Selection is for illustrative purposes only and not to be used to create new catalog numbers.

PowerXL Series—DH1 HVAC/R Drive

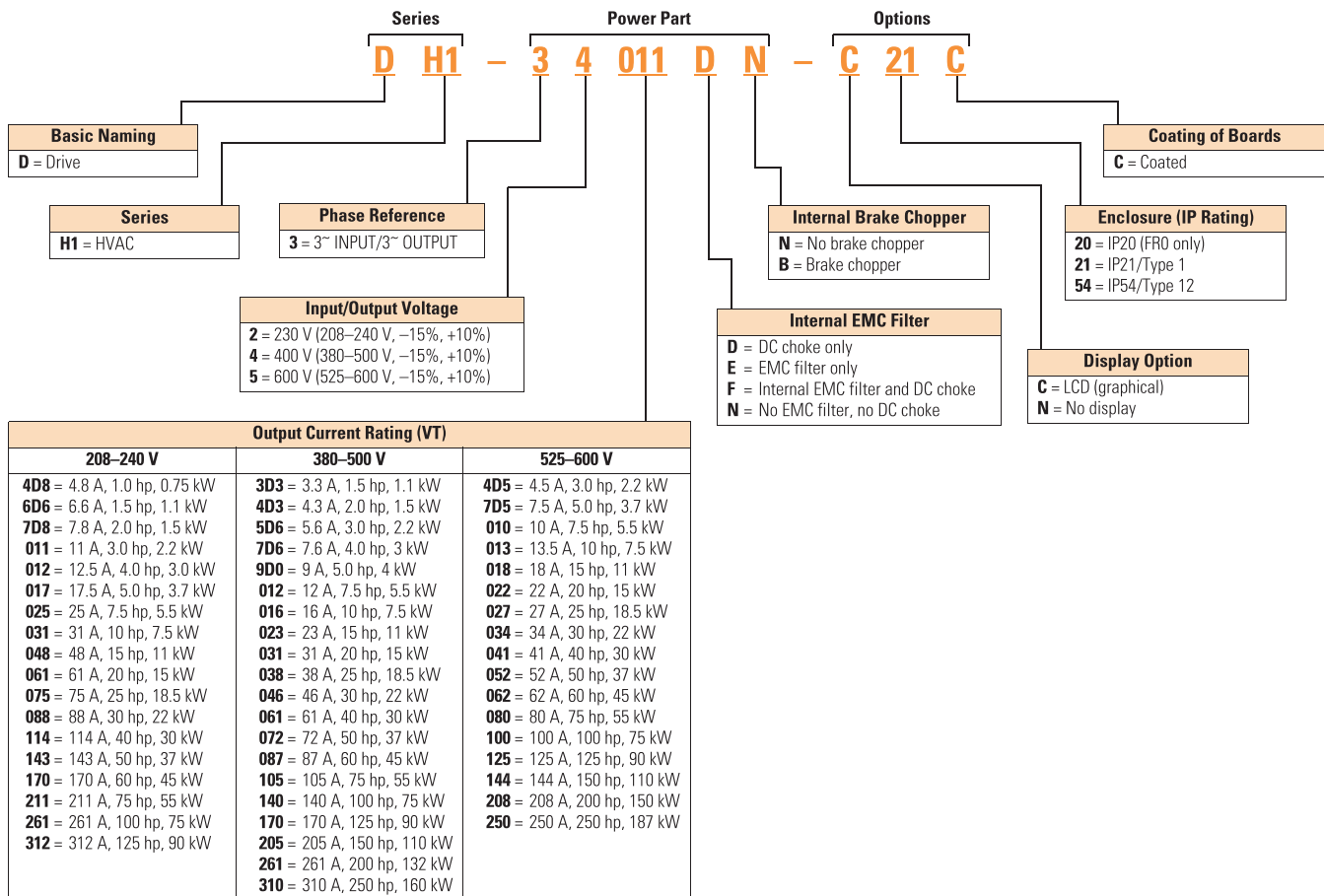

PowerXL Series—DH1 HVAC/R Drive Option Boards

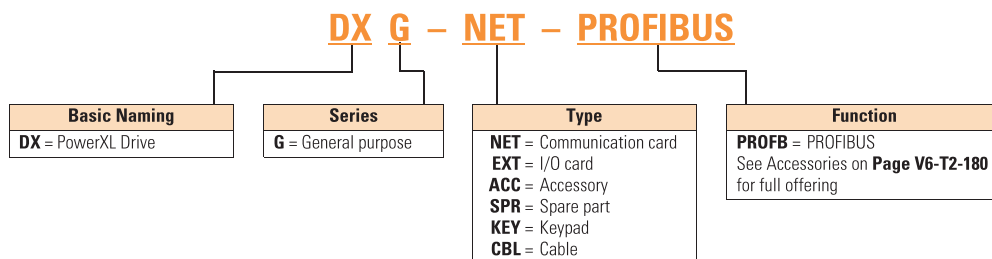

Product Selection

DH1 Series Drives—208–240 Volt

PowerXL Series—DH1 Type 1/IP21



Frame Size	Variable Torque (VT) / Low Overload (I _L)			Catalog Number
	230 V, 50 Hz kW Rating	230 V, 60 Hz hp	Current A	
FR0	0.75	1	4.8	DH1-324D8EB-C20C ①
	1.1	1.5	6.6	DH1-326D6EB-C20C ①
	1.5	2	7.8	DH1-327D8EB-C20C ①
FR1	0.75	1	4.8	DH1-324D8DN-C21C
	1.1	1.5	6.6	DH1-326D6DN-C21C
	1.5	2	7.8	DH1-327D8DN-C21C
	2.2	3	11	DH1-32011DN-C21C
	3	—	12.5	DH1-32012DN-C21C
FR2	3.7	5	17.5	DH1-32017DN-C21C
	5.5	7.5	25	DH1-32025DN-C21C
	7.5	10	31	DH1-32031DN-C21C
FR3	11	15	48	DH1-32048DN-C21C
	15	20	61	DH1-32061DN-C21C
FR4	18.5	25	75	DH1-32075DN-C21C
	22	30	88	DH1-32088DN-C21C
	30	40	114	DH1-32114DN-C21C
FR5	37	50	143	DH1-32143DN-C21C
	45	60	170	DH1-32170DN-C21C
	55	75	211	DH1-32211DN-C21C
FR6	75	100	261	DH1-32261FN-C21C
	90	125	312	DH1-32312FN-C21C

PowerXL Series—DH1 Type 12/IP54



Frame Size	Variable Torque (VT) / Low Overload (I _L)			Catalog Number
	230 V, 50 Hz kW Rating	230 V, 60 Hz hp	Current A	
FR1	0.75	1	4.8	DH1-324D8DN-C54C
	1.1	1.5	6.6	DH1-326D6DN-C54C
	1.5	2	7.8	DH1-327D8DN-C54C
	2.2	3	11	DH1-32011DN-C54C
	3	—	12.5	DH1-32012DN-C54C
FR2	3.7	5	17.5	DH1-32017DN-C54C
	5.5	7.5	25	DH1-32025DN-C54C
	7.5	10	31	DH1-32031DN-C54C
FR3	11	15	48	DH1-32048DN-C54C
	15	20	61	DH1-32061DN-C54C
FR4	18.5	25	75	DH1-32075DN-C54C
	22	30	88	DH1-32088DN-C54C
	30	40	114	DH1-32114DN-C54C
FR5	37	50	143	DH1-32143DN-C54C
	45	60	170	DH1-32170DN-C54C
	55	75	211	DH1-32211DN-C54C
FR6	75	100	261	DH1-32261FN-C54C
	90	125	312	DH1-32312FN-C54C

Note

① IP20 FR0 will be available in June 2018.