



RGS-DT Series

6, 12 and 24V,
NEMA-12 Rated

Type: _____
 Project/Location: _____
 Contractor: _____
 Prepared By: _____
 Date: _____
 Model No.: _____

Harsh environment emergency lighting units steel, thermoplastic or fiberglass cabinets.

The **RGS-DT** Series battery units are specifically designed for use in industrial facilities where equipment is exposed to dust, water, oil or corrosive substances. NEMA-12 classified to protect circuitry from harmful dust or liquid sprays, sealed and gasketed unit cabinets are available in steel, thermoplastic or fiberglass in a variety of sizes.

FEATURES

- Solid-state pulse-type charger – current-limited, temperature compensated, short-circuit proof and reverse-polarity protected.
- Unit comes standard with electronic lockout and brownout circuits
- Sealed dust-proof transfer relay, test switch and LED indicator lights
- Long-life, maintenance-free sealed lead acid battery
- Standard 120/347VAC input with line cord kit
- NEXUS® compatible (for more information on NEXUS®, please consult your sales representative)
- Meets or exceeds CSA C22.2 No. 141-15

See warranty details at: www.tnb.ca/en/brands/lumacell



nexus® NEMA-12

DIMENSIONS

Dimensions are approximate and subject to change.

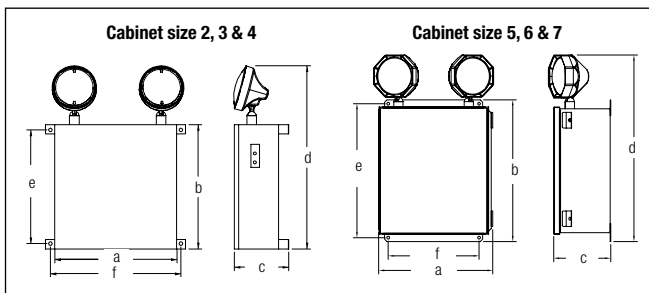
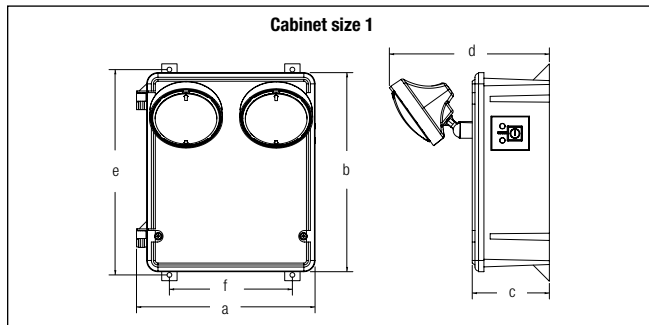

REPLACEMENT LAMPS

MODEL	LAMP TYPE	VOLTAGE/WATTAGE
570.0016-L	Tungsten (LH9W)	6V-9W
570.0025-L	Tungsten (LH9W)	12V-9W
570.0045-L	Tungsten (LH9W)	24V-9W

TYPICAL SPECIFICATIONS

Supply and install a complete emergency lighting system as described here in and shown on the drawings.

The **Lumacell® Smart Diagnostic Micro** controller board shall supply the rated load for a minimum of a 1/2 hour to 87.5% of the rated battery voltage. The unit shall be rated 120V or 347V, 60 Hz and be CSA listed. The unit shall have an output of _____ V.

The charger shall be fully computer tested and its charge voltage factory set to ± 1% tolerance. Chargers with field-adjusted potentiometers are not acceptable. A pulse-type charger shall be employed to promote long battery life and reduce the potential for grid corrosion. The charger shall provide a continuous high charge to recharge the battery, when the battery is at full capacity, the charger will shut-off. Periodically the charger shall provide a pulse of energy to keep the battery topped off. The Pulse charge shall be current limited and precisely regulated by a micro-processing circuit, which samples the battery in relation to its temperature, state or charge and input voltage fluctuations. The charger shall be current limited, temperature compensated, short-circuit proof and reverse polarity protected.

The unit shall be furnished with an electronic lockout circuit, which will connect the battery when the AC circuit is activated, and an electronic brownout circuit, which will activate the emergency lights when utility power dips below 75% of nominal voltage. A low voltage battery protection circuit shall be provided and will disconnect the battery from the fused output circuit at the end of discharge. The unit shall self-test for 1 minute every 30 days, 10 minutes on the 6th month and 30 minutes every 12 months. The unit shall be capable of full recharge in compliance with CSA specifications. The unit shall be furnished with sealed dust tight relay, a test switch and diagnostic LED indicator lights to continuously monitor the status of the unit: Battery Failure, Battery Disconnected, Charger Failure, Lamp Failure, Service Alarm, AC "ON", Charger High Rate.

The unit shall be CSA 22.2 No.141-15 certified.

The unit shall be Lumacell® model: _____

WIRE GUARDS

460.0034-L	Wall Mount
------------	------------

CABINET	DIMENSIONS					
	A	B	C	D	E	F
Thermoplastic Cabinet – size 1	11-5/8" (29.5 cm)	13" (33.0 cm)	5" (12.7 cm)	18-1/4" (46.4 cm)	13-3/4" (34.9 cm)	8" (20.3 cm)
Fiberglass Cabinet – size 2	11-3/8" (28.9 cm)	13-1/2" (34.3 cm)	5-1/4" (13.3 cm)	18-7/8" (47.9 cm)	13-1/2" (34.3 cm)	8-1/8" (20.6 cm)
Fiberglass Cabinet – size 3	13-1/2" (34.3 cm)	15-1/2" (39.4 cm)	6-1/4" (15.9 cm)	20-7/8" (53.0 cm)	-	-
Fiberglass Cabinet – size 4	17-5/8" (44.8 cm)	19-5/8" (49.8 cm)	8-7/8" (22.5 cm)	25" (63.5 cm)	-	-
Steel Cabinet – size 5	10-3/4" (27.3 cm)	13-7/16" (34.1 cm)	5-1/4" (13.3 cm)	18-1/2" (47.0 cm)	12-5/8" (32.1 cm)	9" (22.9 cm)
Steel Cabinet – size 6	12-1/2" (31.8 cm)	15-5/8" (39.7 cm)	6-1/4" (15.9 cm)	20-1/2" (52.1 cm)	14-3/4" (37.5 cm)	10" (25.4 cm)
Steel Cabinet – size 7	16" (40.64 cm)	20" (50.8 cm)	9-1/2" (24.13 cm)	25-3/8" (64.45 cm)	-	-

Type: _____
 Project/Location: _____
 Contractor: _____
 Prepared By: _____
 Date: _____
 Model No.: _____

RGS-DT Series

6, 12 and 24V,
NEMA-12 Rated



POWER CONSUMPTION AND UNIT RATING

MODEL	AC SPECS	WATTAGE CAPACITY				
		30MIN	1H00	1H30	2H00	4H00
RGS36DT	0.10/0.04A	36	21	15	12	6
RGS72DT	0.22/0.08A	72	42	30	24	12
RGS108DT	0.22/0.08A	108	63	45	36	18
RGS180DT	0.22/0.08A	180	105	75	60	30
RG12S36DT	0.09/0.03A	36	21	15	12	6
RG12S72DT	0.15/0.06A	72	42	30	24	12
RG12S100DT	0.34/0.12A	100	58	42	33	17
RG12S144DT	0.40/0.14A	144	84	60	48	24
RG12S200DT	0.41/0.14A	200	117	83	67	33
RG12S250DT	0.41/0.14A	250	144	100	83	42
RG12S360DT	0.43/0.15A	360	200	144	108	60
RG24S144DT	0.55/0.20A	144	84	60	48	24
RG24S288DT	0.67/0.23A	288	168	120	96	48
RG24S350DT	0.67/0.23A	350	200	144	120	60
RG24S432DT	0.67/0.23A	432	250	180	144	72
RG24S550DT	0.88/0.33A	550	320	230	180	90
RG24S720DT	0.88/0.33A	720	400	288	216	120

ORDERING INFORMATION

SERIES	CAPACITY AND CABINET SIZE*	HOUSING	# OF HEADS	HEAD STYLE/LAMP WATTAGE	AC VOLTAGE	OPTIONS
RGS= 6V	36= 36W (1,2,5) 72= 72W (1,2,5) 108= 108W (1,2,5) 180= 180W (1,2,5)	DT= heavy duty steel cabinet DTF=thermoplastic cabinet DTFG= standard fiberglass	Blank= no head 1= one head 2= two heads	WPLD1= MR16 LED, 6V-4W WPLD7= MR16 LED, 12V-4W WPLD9= MR16 LED, 12V-5W WPLD10=MR16 LED, 12V-6W WPLD13= MR16 LED, 24V-4W WPLD14= MR16 LED, 24V-6W LH9W= large tungsten, 6V, 12V, 24V-9W, wedge base LH18W= large tungsten, 12V, 24V-18W, wedge base LH25W= large tungsten, 6V, 12V, 24V-25W, DCB LHQ8W= large halogen, 6V, 12V-8W, bi-pin LHQ12W= large halogen, 6V, 12V-12W, bi-pin LHQ20W= large halogen, 6V, 12V, 24V-20W, bi-pin LHQ55W= large halogen, 12V-55W, bi-pin LHQ70W= large halogen, 24V-70W, bi-pin SB8W= large tungsten, 6V-8W, sealed beam SB18W= large tungsten, 6V, 12V-18W, sealed beam SB25W= large tungsten, 6V, 12V-25W, sealed beam QSB8W= large halogen, 6V, 12V-8W, sealed beam QSB12W= large halogen, 6V, 12V-12W, sealed beam QSB20W= large halogen, 6V-20W, sealed beam RB8W= large rubber tungsten, 6V-8W, sealed beam RB18W= large rubber tungsten, 6V, 12V-18W, sealed beam RB25W= large rubber tungsten, 6V, 12V-25W, sealed beam RBQ8W= large rubber halogen, 6V, 12V-8W, sealed beam RBQ12W= large rubber halogen, 6V, 12V-12W, sealed beam RBQ20W= large rubber halogen, 6V-20W, sealed beam	Blank= 120/347VAC input ZC= 277VAC input	AT= auto-test* ATN= auto-test, non-audible* NEX= NEXUS® system interface* NEXRF= wireless NEXUS® system interface* V= voltmeter A= ammeter LC= line cord (120V only)*** LD= lamp disconnect LTS= light activated test switch RR2= remote test receiver** TC= teflon coated lens**** TD= time delay (programmable) TL= twist lock plug (120V only)*** TMBB= AC/DC terminal block TMBD= DC terminal block TMBK= AC terminal block
RG12S= 12V	36= 36W (1,2,5) 72= 72W (1,2,5) 100= 100W (1,2,5) 144= 144W (1,2,5) 200= 200W (1,2,5) 250= 250W (3,6) 360= 360W (3,6)					
RG24S= 24V	144= 144W (1,2,5) 288= 288W (1,2,5) 350= 350W (4,7) 432= 432W (4,7) 550= 550W (4,7) 720= 720W (4,7)					

* Cabinet size not part of nomenclature.

* Minimum lamp load required: 20% of unit capacity.
 * Not all options are available with NEXUS®. Please consult your sales representative.
 ** HH2= remote test transmitter (sold separately)
 *** 120V is standard
 **** Not available with WPLD head style

EXAMPLE: RGS36DTLH9W