

# PowerXL DH1 series overview

## Product overview



# PowerXL DH1 series overview

## DH1 catalog number scheme

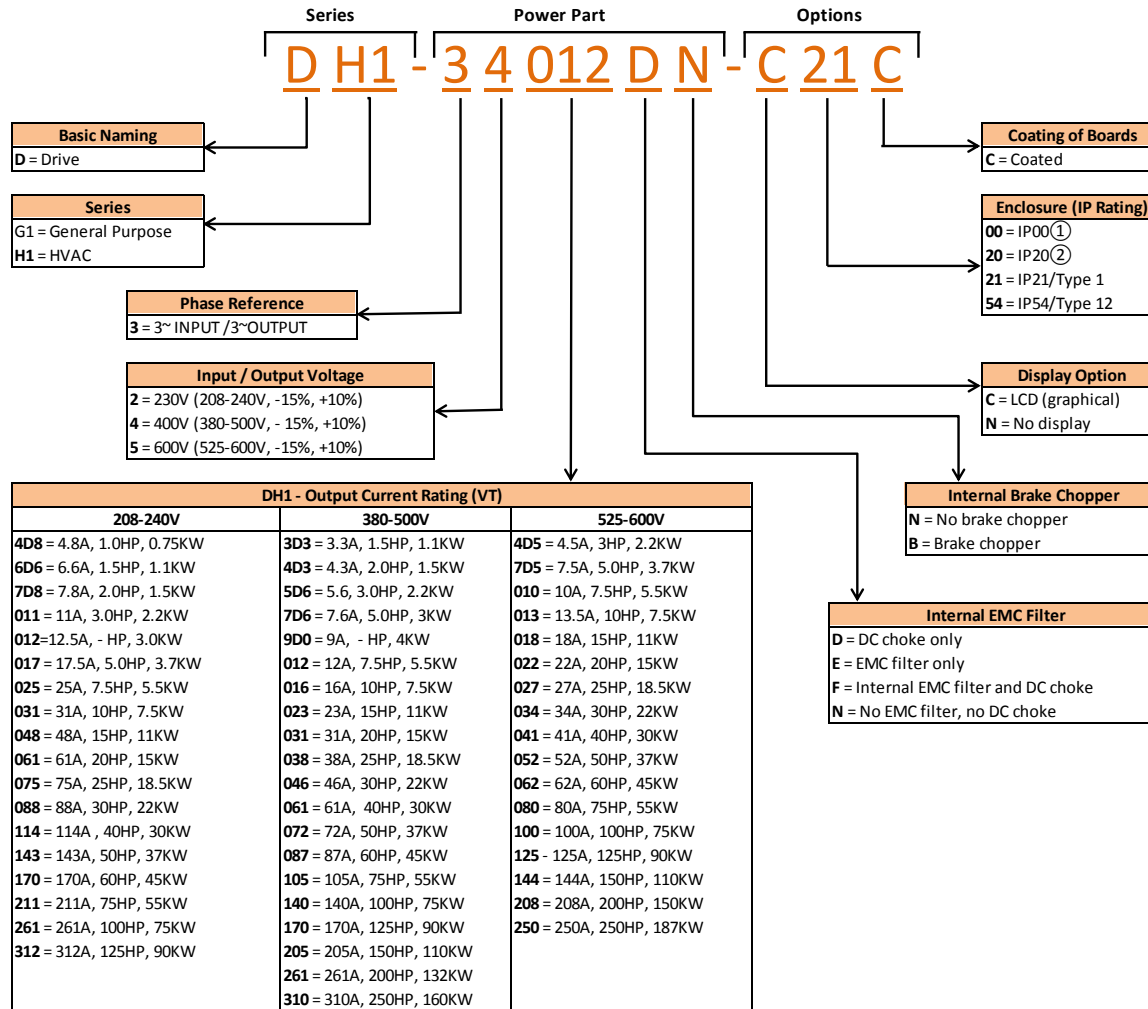

① IP00 FR7 and FR8 is not available for 230V input product or with the PowerXL DH1 Product  
 ② IP20 FRO will be available in June 2018