

ORDERING INFORMATION

Order code: 10047
 Description: BHPS1000/347/480/600/C/CWI/H/K
 UPC: 69549100473

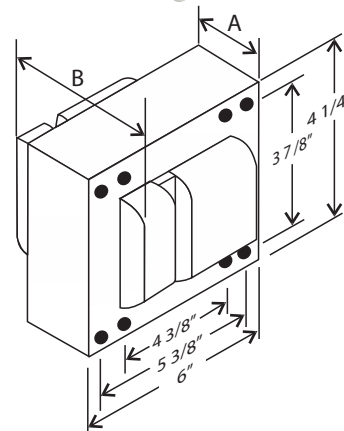

4 1/4" x 6" Core

SPECIFICATIONS

Ballast type: Magnetic high pressure sodium
 Ballast style: Core and coil
 Circuit type: CWI
 ANSI code: S52
 Input voltage (V): 347/480/600
 Input frequency (Hz): 60
 Line volt regulation: ± 10 %
 Line watt regulation: Within trapezoid
 Insulation class: H (180°)



Input voltage (V)	Operating current (A)	Open circuit current (A)	Starting current (A)	Rated lamp watts (W)	Input watts (W)	OCV (V)	Dropout voltage (V)	UL 1029 code	Fuse rating (A)	Input current (A)	Power factor	Starting temperature
347	3.46	2.83	1.85	1 000	1 100	420	240	E	10	0.86 - 1.50	0.90	-40°F / -40°C
480	2.50	1.82	1.16	1 000	1 100	420	340	B	8	0.74 - 1.13	0.90	-40°F / -40°C
600	2.00	1.52	1.10	1 000	1 100	420	430	B	6	0.57 - 0.9	0.90	-40°F / -40°C

HIGH POTENTIAL TEST (V)

1 minute:	2 200
2 seconds:	2 650
OCV test:	395 - 470
Short circuit:	6.20 - 6.90

BALLAST DIMENSIONS

Dimension A:	5.60"
Dimension B:	7.60"
Lead Lengths:	12.00"
Weight (lbs):	41.00

WIRING DIAGRAM

Ground ballast core

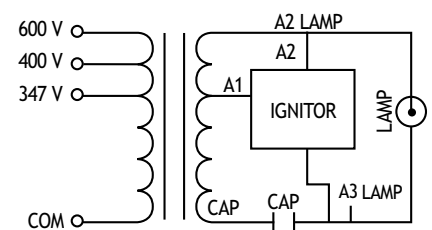

BRACKET

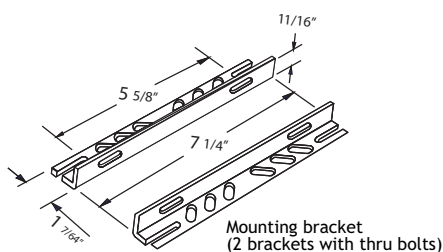

CAPACITOR

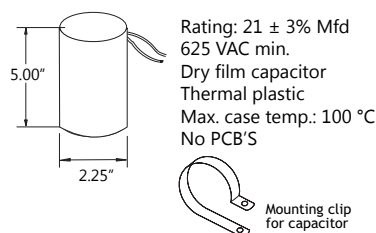

IGNITOR

