



VISION



A30 SMART CAMERA

The A30 Series is a stand-alone, general purpose and cost effective Smart Camera that can be installed even in harsh industrial environments thanks to its IP67 rated housing. The A30 Series features a VGA (640x480) CCD imager, built-in discrete I/Os as well as Ethernet and Serial interfaces. Thanks to the ultimate programming flexibility offered by Impact software, the A30 Series represents the answer to every machine vision need.

HIGHLIGHTS

- IP67 Rated Enclosure with sealed connectors – No bulky ‘add on’ enclosure required for harsh environments
- High quality VGA CCD sensor – delivering reliable and stable image quality performance
- Can be run with or without an operator interface – For full turnkey integration capability or standalone use
- Complete Impact software toolset for ultimate programming flexibility – Ability to address any inspection and user interface needs through Impact software
- Complete communications support, including RS232 Serial, Ethernet and Discrete I/O – For easy data transfer to any industrial platform
- Real-time operating system – Offers highly deterministic timing for precise output of inspection results

PRODUCT SPECIFICATIONS

Resolution	640 x 480 CCD
Pixel size	7.4 x 7.4 um
Imager size	1/3"
Lens mount	C-Mount
Frames/sec	60
Processor	800 MHz TI Da Vinci
Housing	Right Angle - IP67
Housing dimensions maximum (LxWxH)	123 x 65 x 86 mm (4.84 x 2.55 x 3.41 in)
Dedicated I/O	1 In / 1 Out
Configurable I/O	1 In / 2 Out
I/O optically isolated	YES
External button	YES
Power requirements	10-30 VDC 1.0 - 0.33 A
RS-232 serial	YES
Ethernet	YES
Storage	256 MB Flash
RAM	512 MB
Operating Temperature	0 to 45 °C
Humidity (non-condensing)	0 to 90%
Certifications	CE, CSA

APPLICATIONS

Surface Flaw Detection

The A30 smart camera is perfectly suited to identify flaws such as scratches, porosity and other defects in the surfaces of machined materials or other finished goods. The system will identify and quantify the size, location and number of defects allowing for easy defect sorting and analysis. Additionally, the integrated high speed I/O will allow for fast rejection or signaling of inspection results to reject mechanisms or other devices such as PLCs. Viewing images and inspection data, as well as controlling the A30's settings, can be done through Impact's Control Panel Manager software.



Hi-Speed Product locating

With powerful high speed features, that rival more expensive PC based systems, the cost effective A30 is excellent for accurately finding part position and rotation of product - in mere milliseconds. This capability makes the smart camera perfect for locating moving parts or



compensating for movement in manufacturing processes that present products in an inconsistent manner during inspection. This capability is a standard feature of the A30 product and enhances the smart camera's inspection performance.

Template Matching

When contoured products, such as stamped connector pins, need inspections for edge variation or surface defects, the A30 can provide reliable testing at speeds up to 60 images per second with template matching. When the system trained on a good or 'golden' part, variations found in inspected parts can be quantified for both size and number of defects. Tolerance parameters can then be set to allow small acceptable variations and or a maximum number of found defects in the inspected product. The operator is shown where the defects are found, by highlighted areas surrounding the defect, in the part image.

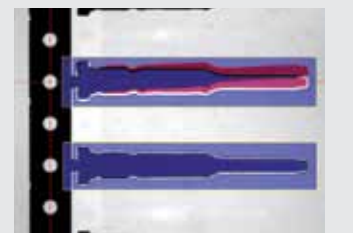

HMI INTERFACE



LED Color	Red	Yellow	Yellow	Yellow	Green
LED Function	Busy	Out 1	Out 2	Out 3	On Line

CONNECTORS

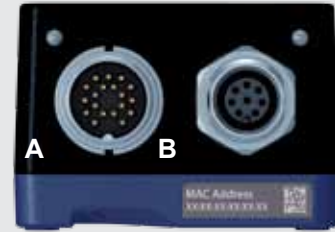

A - M16 Male 19 poles (I/O & Power)
B - M12 Female 8 poles A-Coded (Gigabit Ethernet)

DIMENSIONS

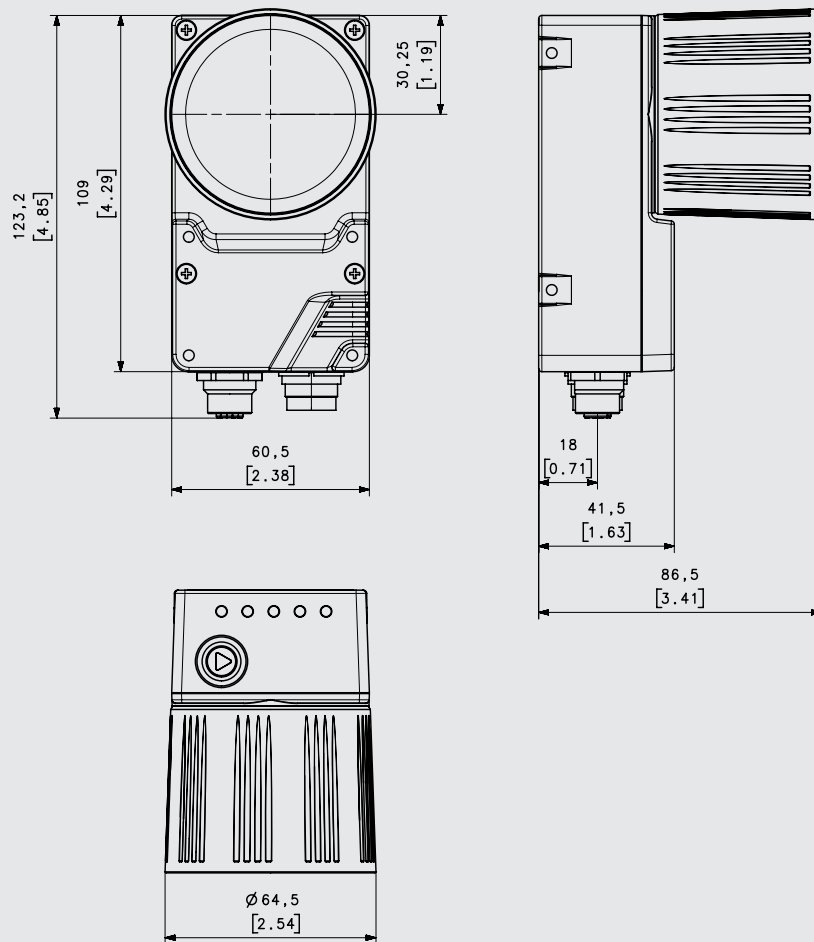

mm
[inch]