

# Distribution

## TRANSFORMER MOUNTING



### Transformer Cluster Mount

For mounting 3 transformers with the following maximum weights:  
 40TCM up to 3 x 650 lbs.  
 65TCM up to 3 x 1300 lbs.  
 100TCM up to 3 x 2250 lbs.  
 Bolts for mounting transformers included. Lifting eye provided.

Cat.No.	Dimensions					Std.Pkg.	Wt.-lbs./each
	A	B	C	D	E		
40TCM	29-7/8	11-3/8	15	-	23-1/2	1	40
65TCM	34-1/4	12-7/8	22	15	27-5/8	1	65
100TCM	34-3/8	12-1/8	29	22	37-1/2	1	100
* 654TCM	34-1/4	12-7/8	22	15	27-5/8	1	65
652TCM	34-1/4	12-7/8	22	15	30-1/2	1	67

Holes are provided for grounding clamps, insulator pins and stabilizing braces.  
 Stabilizing brackets available upon request.  
 \*with stabilizer bracket



Stabilizer Bracket

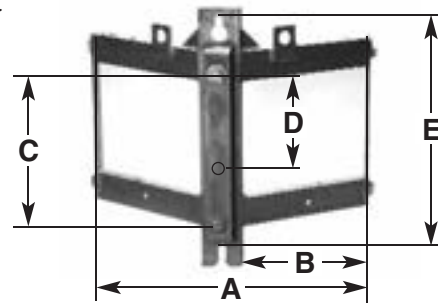

65TCM

### Aluminum Transformer Mounting Bracket

Single transformer mounting bracket. For transformer up to 1300 lbs.  
 C/W 3/4" x 3" Galvanized Bolts, Flatwasher, Lockwasher, and Nut  
 Top mounting hole supplied with two 1-4" x 3" square washers.

Cat.No.	Dimensions				Std.Pkg.	Wt.-lbs./each
	A	B	C	D		
AH370TM	36	30	6	2	1	40
AH349TM	35	29-11/16	6	2	1	65

