

TF TRANQUIL BATHROOM FANS

TF Tranquil Bathroom Fans are available in non-lighted and lighted versions, providing superior ventilation and efficient performance that is suitable for all interiors. The built-in damper prevents a backdraft, keeping tempered air in a home when the fan is not operating.

FEATURES & BENEFITS

- Whisper-quiet, under 1 sone
- Non-lighted (TF80 & TF110) & lighted (TF80L & TF110L) versions
- Clean, simple grille design
- Galvanized steel housing
- Easy installation
- Double hanger mounting brackets adjust up to 24" span
- Built-in backdraft damper
- Efficient AC motor
- 120V, 60 Hz operation
- Automatic reset thermal overload protection
- Max 26W GU24 fluorescent light
- Available to fit duct sizes 4" & 6"



ACCESSORIES / OPTIONS

- Controls - pages 36-37
- Accessories - pages 38-39

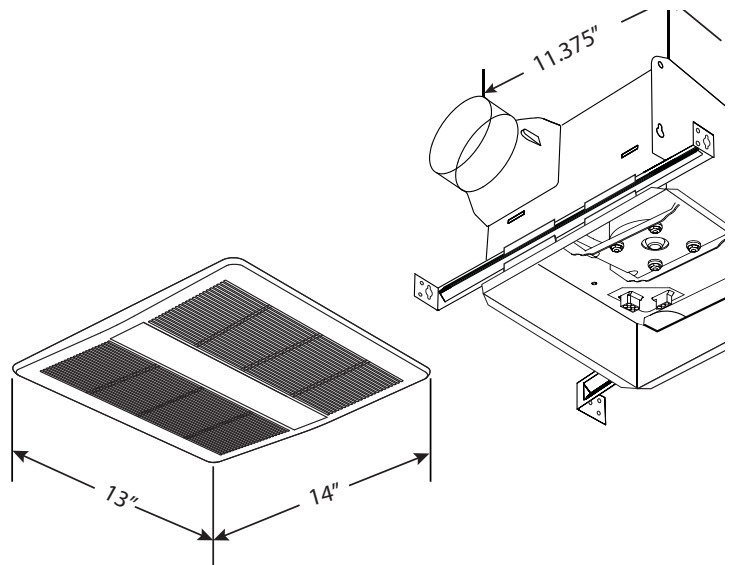
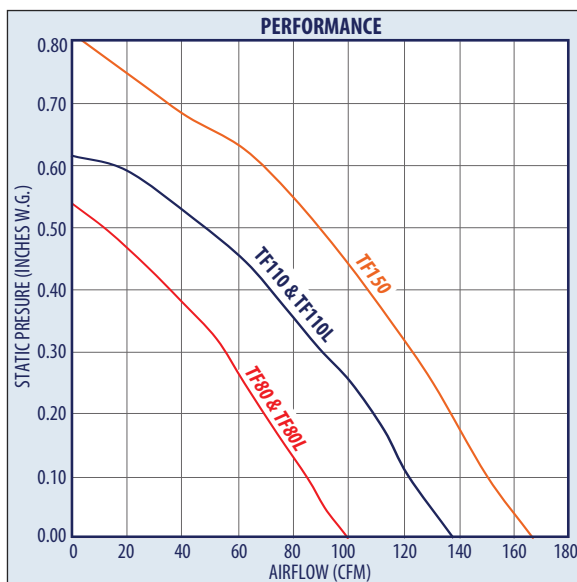

MODEL	PERFORMANCE				ENERGY STAR® QUALIFIED
	CFM 0.1" SP	CFM 0.25 SP	SONES	WATTS	
NON-LIGHTED FANS					
TF80	80	58	0.4	25.0	Yes
TF110	110	100	0.9	33.0	Yes
TF150	150	130	1.1	43.2	No
LIGHTED FANS					
TF80L	80	58	0.4	25.0	Yes
TF110L	110	100	0.9	33.0	Yes

MODEL	DUCT DIA.	GRILLE SIZE	HOUSING SIZE			WT LBS
			L	W	H	
NON-LIGHTED FANS						
TF80	4 & 6	13 x 14	11.375	10.5	7.625	5.0
TF110	4 & 6	13 x 14	11.375	10.5	7.625	5.0
TF150	6	13 x 14	11.375	10.5	7.625	5.0
LIGHTED FANS						
TF80L	4 & 6	13 x 14	11.375	10.5	7.625	5.0
TF110L	4 & 6	13 x 14	11.375	10.5	7.625	5.0

*DO NOT USE FOR CONSTRUCTION

CONSULT FACTORY FOR CERTIFIED PRINTS

