



new product



MP-BLD Series

"Built-in" micro LED lamp remote fixture

FEATURES

- 6 to 12V, 3W LED each head
- Fire-retardant thermoplastic
- 300° rotation
- CSA certified to C22.2 No.141-15

See warranty details at: www.tnb.ca/en/brands/lumacell

TYPICAL SPECIFICATIONS

Lamp head and stem shall be injection molded, impact resistant, flame retardant thermoplastic. Fixture shall be supplied with a canopy for installation on any four inch octagon box.

The remote fixtures shall be certified to CSA 22.2 No.141-15.

The remote unit shall be the Lumacell® model: _____.

WIRE GUARDS

460.0029-L	Wall ceiling Mount
------------	--------------------

DIMENSIONS

Dimensions are approximate and subject to change.

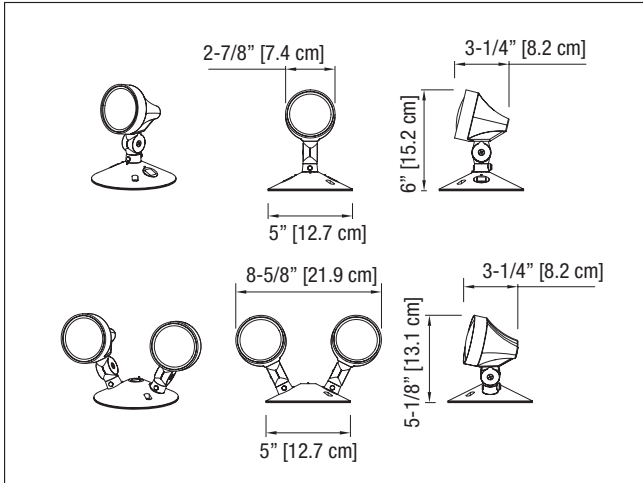

ORDERING INFORMATION

SERIES	NUMBER OF HEADS	LAMP TYPE
MP= Plastic built-in LED	1= Single head 2= Double heads	BLD= Plastic built-in LED, 6V / 12V, 3W each

EXAMPLE: MP1BLD