



Power supply, 1 ph, 85-264VAC, 24VDC/5A



Powering Business Worldwide™

Part no. PSG120E  
Article no. 131318

Catalog No.

## Delivery programme

Product range		Power supplies PSG
Phases		1-phase
Input voltage range	V	85 - 264 V AC
Nominal input voltage		120 - 375 V DC
Rated output voltage		100 - 240 V AC
Measuring output current	CSA	24 V DC (± 2%)
Setting range for the output voltage		5
Rated output power	W	22-28 V DC
		120

## Input characteristics

Nominal input voltage		100 - 240 V AC
Supply frequency		
Rated value	Hz	50/60
Range	Hz	47 - 63
Rated operational current	$I_n$	A
		1.4 bei 115 V AC, 0.8 bei 230 V AC
Mains failure bridging		ms
		> 35 at 115 V AC
		> 70 at 230 V AC
Run-up time after mains voltage applied		ms
		1000
Internal input fuse (device protection, not accessible)		
		T3.15 AH/250 V
Back-up fuse		
		6, 10, 16 A (recommended)
Tripping characteristic		
		B
Discharge current to PE		mA
		< 1

## Output characteristics

Rated output power		W
		120
Rated output current $T_u$  60 °C		A
Derating from $T_{amb} > +50$ °C		
		2.5 % per Kelvin temperature increase
Capacitive load starting		
		Max 10000 µF
Heat dissipation		W
		22.5
Efficiency		%
		> normally 84
Residual ripple and switching peaks		
		20 MHz: < 50 mV/< 240 mVpp
Can be switched in parallel		
		with ORing Diode

## General characteristics

Housing		
		Aluminum (Al5052)
Status indication		
		DC OK: LED green
Height		mm
		121
Width		mm
		50
Depth		mm
		115
Weight		kg
		0.54
Terminations		
		Screw connection
Stripping length		mm
		7
		or suitable cable lug for crimping
Ambient temperature, operation		°C
		-20 - +75 (> 50 °C derating)
Ambient temperature, storage		°C
		- 20 - + 85
Climatic proofing		
		< 95 % relative humidity at +25 °C, no condensation
Vibrations (IEC/EN 60068-2-6)		
		10 – 150 Hz, accel. 50 m/s <sup>2</sup> , 0.35 mm, single amplitude (5 g max.) for 90 min. in X, Y, Z direction
Pollution degree		
		2
Climatic class (IEC)		
		3K3 according to EN 60721

## Safety and safety features

Transient overvoltage protection		
		Varistor

Current limitation at short-circuit		I <sub>Überstrom</sub> = 150 % der max. Ausgangsleistung
Overvoltage protection		Yes, against internal overvoltage
Insulation voltage		
Inputs/outputs		4 kV AC (type test), 3 kV AC (routine test)
Input		1.5 kV AC (type test), 1.5 kV AC (routine test)
Output		1.5 kV AC (type test), 500 V AC (routine test)
Protection type		IPX0
Protection class		Class I with PE connection
Mechanical shock resistance (IEC 60068-2-27)		30 g (300 m/s <sup>2</sup> ) in all directions according to IEC 60068-2-27

## Standards

		Electrical equipment of machines: IEC60204-1 (Overvoltage category III) Equipping power installations with electronic apparatus: EN 50178/IEC 62103 Safety extra-low voltage: PELV (EN 60204), SELV (EN 60950) Protection against electric shock: DIN 57100-410 CE: In conformance with EMC Directive 2004/108/EC and Low Voltage Directive 2006/95/EC ITE: EN 55022, EN 61000-3-2, EN 61000-3-3, EN 55024 Industrial: EN 55011 Mains harmonics limitation: EN 601000-3-2
--	--	--

## Technical data ETIM 5.0

PLC's (EG000024) / PLC system power supply (EC000599)

Electric engineering, automation, process control engineering / Control / Programmable logic control (SPS) / SPS system power supply (ecl@ss8-27-24-22-09 [AKE532010])

Input voltage at AC 50 Hz	V	85 - 264
Input voltage at AC 60 Hz	V	85 - 264
Input voltage at DC	V	120 - 375
Type of voltage (input voltage)		AC/DC
Max. input current AC 50 Hz	A	1.4
Max. input current AC 60 Hz	A	1.4
Max. input current DC	A	1
Type of output voltage		DC
Output voltage at AC 50 Hz	V	0 - 0
Output voltage at AC 60 Hz	V	0 - 0
Output voltage at DC	V	22 - 28
Max. output current AC 50 Hz	A	0
Max. output current AC 60 Hz	A	0
Max. output current DC	A	5
Redundancy		No
Suited for safety functions		No
Width	mm	50
Height	mm	121
Depth	mm	115

## Dimensions

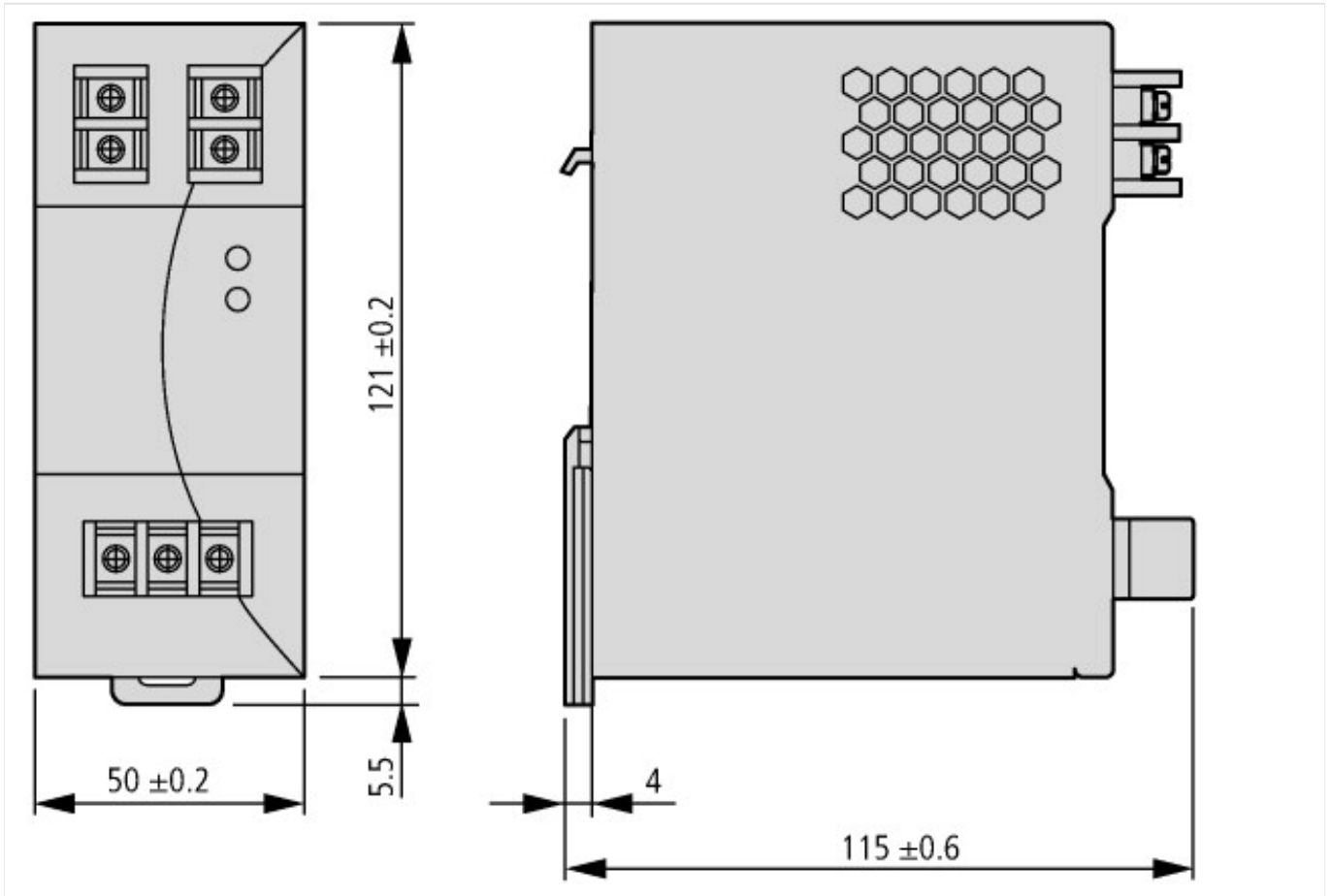

[Additional product information \(links\)](#)

IL00912002E

IL00912002E