

Twist-Lock® Devices
50 A Twist-Lock® Accessories
Weatherproof Cover

HUBBELL

Features

- Cast aluminum

Ordering Information

Description	Cord Diameter	UPC	Catalog Number
1-Gang, For 50A Receptacles, FS/FD Mount, Cast Aluminum With Liftcover		783585809519	HBL7770



Listings

Listed to UL Standard

Specifications

Weight	0.75
--------	------

Performance

Environmental

Moisture Resistance	IP44
---------------------	------

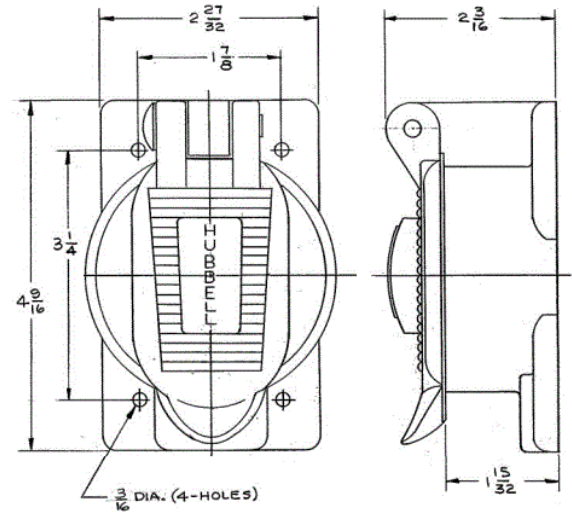

Accessories

Receptacle Accommodation	50 Ampere Twist-Lock®
--------------------------	-----------------------

Resources

Customer Use Drawing
eCatalog

Dimensions in Inches (mm)

Hubbell Wiring Device-Kellems • Hubbell Incorporated (Delaware) • 40 Waterview Drive • Shelton, CT 06484

Phone (800) 288-6000 • Fax (800) 255-1031 • Specifications subject to change without notice.

