

Twist-Lock® Devices
Accessories
Weatherproof Cover

HUBBELL

Features

- Gray thermoplastic, corrosion resistant
- Weatherproof Plate for Flanged Inlets and Flanged Receptacles

Ordering Information

Description	Cord Diameter	UPC	Catalog Number
For all 4 & 5 Wire 20A & 30A Insulgrip® Flanged Units		783585392288	WP2



Listings

Listed to UL Standard
Certified to CSA Standard

Specifications

Weight	0.3
--------	-----

Performance

Environmental	
Flammability	UL 94 V0 for Receptacles and Inlets.HB or better for Plugs and Connectors
Moisture Resistance	IP44
Operating Temperatures	Maximum Continuous 75°C Minimum -40°C (w/o impact)

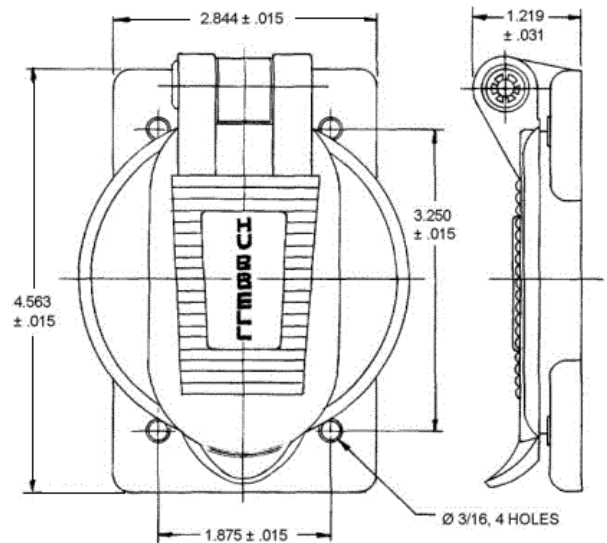

Accessories

Receptacle Accommodation	20 Amp and 30 Amp Round Nylon Flanged Receptacles and Flanged Inlets
--------------------------	--

Resources

Customer Use Drawing
eCatalog

Dimensions in Inches (mm)

Hubbell Wiring Device-Kellems • Hubbell Incorporated (Delaware) • 40 Waterview Drive • Shelton, CT 06484

Phone (800) 288-6000 • Fax (800) 255-1031 • Specifications subject to change without notice.

