

## MATERIALS

### Carbon Steel

Carbon steel is used in the manufacture of B-Line series pipe hangers and supports. Excellent strength characteristics and adaptability to cold forming provide a well engineered design. By cold forming the steel, mechanical properties are increased, adding to the structural integrity of the fabricated hanger.

### Stainless Steel

AISI Type 304 and Type 316 are non-magnetic members of the austenitic stainless steel group. Several conditions make the use of stainless steel ideal. These include reducing long term maintenance costs, high ambient temperatures, appearance, and stable structural properties such as yield strength, and high creep resistance.

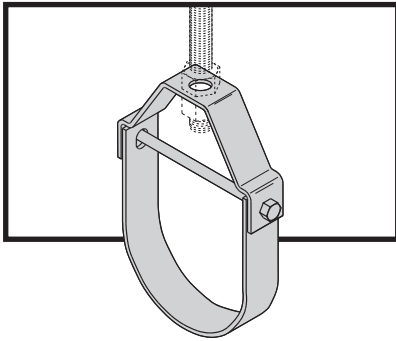

## CORROSION

All metal surfaces exposed to the environment are affected by corrosion. Depending on the physical properties of the metal and its proximity to other dissimilar metals, an electrochemical reaction may occur which causes an attack on the metal itself, resulting in corrosion. Chemical corrosion is limited to highly corrosive environments, high temperatures, or a combination of both.

## FINISHES

### Zinc Coatings

Protective zinc coatings are available on a number of pipe hangers and accessories in three basic forms: Electro-galvanized, pre-galvanized, and hot-dip galvanized after fabrication. In all cases, the zinc protects the steel first as a sacrificial anode to repair bare areas on cut edges and gouges.

When exposed to air and moisture, zinc forms a tough, adherent protective film consisting of a mixture of zinc oxides, hydroxides, and carbonates. The corrosion resistance of zinc is directly related to its thickness and the environment. For example a 0.2 mil (5  $\mu\text{m}$ ) coating will last twice as long as a 0.1 mil (2.5  $\mu\text{m}$ ) coating in the same environment.

### Electro-Galvanized (ASTM B633 SC1 or SC3)

An electro-galvanized process deposits a coating of zinc on the steel by electrolysis from a bath of zinc salts. This coating is pure zinc and adheres to the steel with a molecular bond. A maximum of 0.5 mils (12.7  $\mu\text{m}$ ) of zinc can be applied by this method. This coating is recommended for in-door use in relatively dry areas.

### Pre-Galvanized Zinc (ASTM A653 Coating Designation G90)

Pre-galvanized zinc is produced by continuously rolling the steel coils or sheets through molten zinc at the steel mills. This is also known as "mill-galvanized" or "hot-dipped mill galvanized". Coils are then slit to size for fabrication of pipe hangers. Coating thicknesses of G90, is 0.90 ounces per square foot (0.27  $\text{kg}/\text{m}^2$ ) of steel surface.

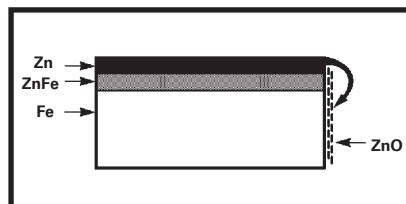

Protection of cut edges with zinc coatings.

Cut edges and welded areas are not zinc coated; however, zinc near the uncoated metal becomes a sacrificial anode which protects the bare areas after a short period of time. Pre-galvanized steel is not generally recommended for use outdoors in industrial environments, but is suitable for extended exposure in dry or mildly corrosive atmospheres.

### Hot-Dip Galvanized After Fabrication (ASTM A123)

After a pipe hanger or fitting has been fabricated, it is completely immersed in a bath of molten zinc. A metallurgical bond is formed, resulting in a zinc coating that completely coats all surfaces, including edges. Zinc coatings of this specification have a minimum thickness of 1.50 ounces per square foot (0.45  $\text{kg}/\text{m}^2$ ) on each side or a total of 3.0 ounces per square foot (0.9  $\text{kg}/\text{m}^2$ ) of steel.

Hot-dip galvanized after fabrication is recommended for outdoor exposure. For best results, a zinc rich paint (available from Eaton) should be applied to field cuts. The zinc rich paint will provide immediate protection for field cuts and eliminate the short time period for galvanic action to "heal" the damaged coating.

### Plastic Coating

Some products offered by Eaton are plastic or vinyl coated for prevention of galvanic reaction between materials or for noise reduction. These coated products can also be used where contact between glass pipe and hanger is not desirable. Felt lined hangers may be substituted for same purpose.

### Red Primer

A corrosion resistant metal primer containing rust inhibitive pigments.

## DURA-COPPER and DURA GREEN Epoxy Coatings

DURA-COPPER™ and DURA GREEN™ are water borne epoxy coatings applied to B-Line series products by a precisely controlled cathodic electro-deposition process. This process is accomplished using a conveyor to transport parts through several cleaning, phosphatizing and application stages prior to being baked (See diagram below).

This custom designed paint system is used for painting all copper painted hanger parts and all green channel, slotted angle and fittings.

Samples are selected on a routine basis for Salt Spray (fog) testing to verify the quality of the finish. These tests are performed in accordance with ASTM B117-73 and evaluated and rated according to ASTM D1654-79 (Tables 1 & 2). The DURA-COPPER and DURA GREEN Epoxy coatings have been tested and listed by Underwriters Laboratories in accordance with "Standard for Pipe Hanger Equipment for Fire Protection Service, UL 203" and meet or exceed all requirements of Federal Specification TT-C-490B Paragraph 3.

## Quality Assurance

Eaton's Quality Assurance Program has been developed and implemented for compliance to various industry standards and specifications.

## DURA-COPPER & DURA GREEN EPOXY COATING PROCESS

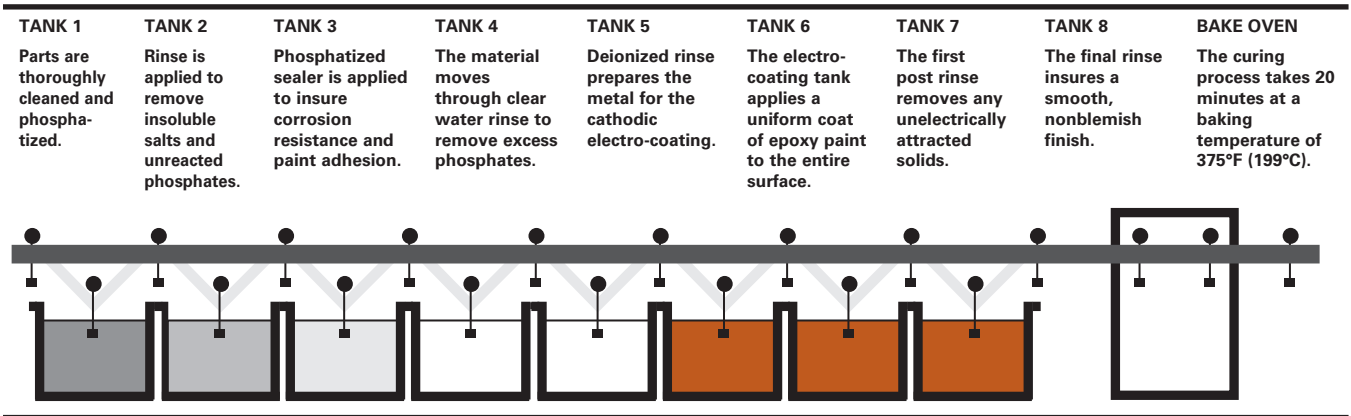

## SALT SPRAY TEST RESULTS

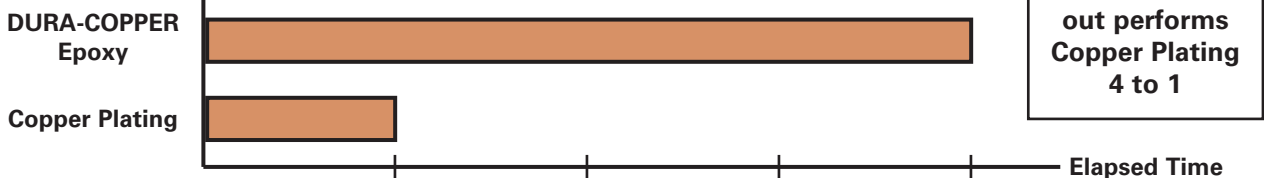

(1) All salt spray (fog) tests conducted in accordance with ASTM B117-73 and evaluated and rated according to ASTM D1654-79 Tables 1 & 2. Tests were performed and certified by an independent testing laboratory.

## General Information

### Torque

The torque values in this catalog are to be used as a guide only. The relationship between the applied torque or torque wrench reading and the actual tension created in the bolt may be substantially different. Important factors affecting torque-tension relationships include friction under the bolt head or nut, hole tolerances, and torque wrench tolerances. Accuracy of many commercial torque wrenches may vary as much as plus or minus 25%.

### Charts and Tables

Charts and tables in this section are compiled from information published by nationally recognized organizations and are intended for use as a guide only. Eaton recommends that users of this information determine the validity of such information as applied to their own applications.

**Eaton reserves the right to make specification changes without notice.**

# Beam Clamps



Beam clamps offered in this section are designed to provide attachment of hanger rods to structural members without drilling or welding. A wide range of types and sizes are available for various applications.

## Materials

Carbon Steel, Malleable Iron and Forged Steel are used in the manufacturing of beam clamps and accessories. Stainless steel and other materials are available.

## Finishes

The standard finishes for mechanical supports are plain steel (oil coated) sometimes referred to as black and Electro-Galvanized Zinc (ASTM B633 SC3). Hot-Dip Galvanized After Fabrication (ASTM A123), Red Primer, Plastic Coating and DURA GREEN™. Other special coatings are available upon request.

Note: Due to the design of some products, (threads, connecting hardware, swivels, etc.) items may or may not be uniformly coated with special finishes. In some cases, the hanger itself may be coated, however, the hardware may be supplied Electro-Plated, copper plated, or in stainless steel.

Recommended Set screw Torque (unless otherwise specified)

1/4"-20	3/8"-16	1/2"-13	5/8"-11	3/4"-10
4 ft/lbs (5 Nm)	5 ft/lbs (7 Nm)	11 ft/lbs (15 Nm)	21 ft/lbs (28 Nm)	34 ft/lbs (46 Nm)

Over torqued set screws will damage beam clamps in this section.

We are aware that torque wrenches are not used or not available in many instances. In the absence of a torque wrench, the set screw should be finger tightened to the I-beam and then an additional 1/4 to 1/2 turn applied to the set screw.

## Approvals (as noted)

Items in this section are Underwriters Laboratories Listed, Factory Mutual Approved, and comply with Federal Specification WW-H-171E & A-A-1192A or Manufacturers Standardization Society ANSI/MSS SP-69 & SP-58.

# Beam Clamps

## B3034 - C-Clamp

**Size Range:** 3/8"-16 thru 3/4"-10 rod

**Material:** Cast Malleable Steel with hardened cup point set screw and jam nut

**Function:** Recommended for hanging from steel beam where flange thickness does not exceed 3/4" (19.0mm).

**Features:** May be used on top or bottom flange of the beam. Beveled lip allows hanging from top flange where clearance is limited. may be installed with the set screw in the up or down position. Offset design permits unlimited rod adjustment by allowing the rod to be threaded completely through the clamp. The rear window design permits inspection of thread engagement.

**Approvals:** Underwriters Laboratories Listed in the USA (UL) and Canada (cUL), and Factory Mutual Engineering Approved (FM) for 3/8"-16 and 1/2"-13 rod sizes. Conforms to Federal Specification WW-H-171E & A-A-1192A, Type 19 & 23 and Manufacturers Standardization Society ANSI/MSS SP-69 & SP-58, Type 19 & 23. 3/8"-16 is (cULus) Listed to support up to 4" (100mm) pipe with the set screw in the down position, up to 3" (75mm) pipe with the set screw in the up position. 1/2"-13 is (cULus) Listed to support up to 8" (200mm) pipe with the set screw in the down position, up to 6" (150mm) pipe with the set screw in the up position.

**Finish:** Plain. Contact customer service for alternative finishes and materials.

**Order By:** Part number and finish



B3034-3/8" and B3034-1/2" sizes  
Attach only as shown.

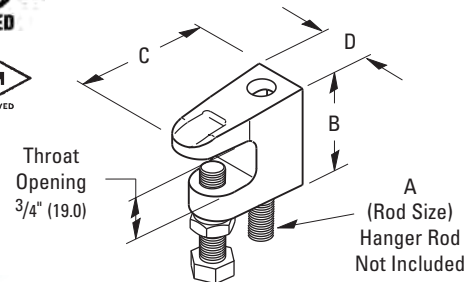

Set Screw and Locknut Included



B3034-3/8  
Shown

Top Flange  
Attachment  
Applications

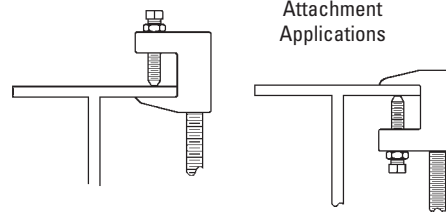

Bottom Flange  
Attachment  
Applications

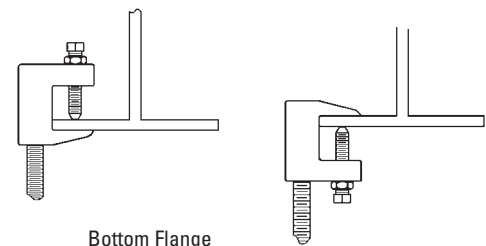

B3034-5/8" and B3034-3/4" sizes  
Attach only as shown.

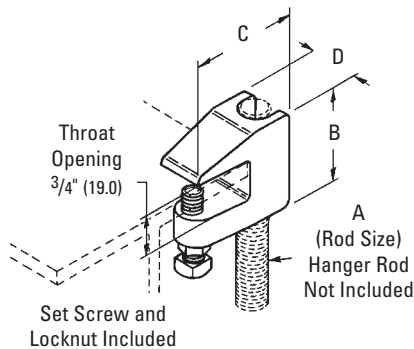

Part No.	Rod Size A	B		C		D		Design Load with Setscrew		Maximum Iron Pipe Size Per UL		Approx. Wt./100	
		in.	(mm)	in.	(mm)	in.	(mm)	Lbs.	(kN)	in.	(mm)	Lbs.	(kg)
B3034-3/8	3/8"-16	1 5/8"	(41.3)	2"	(50.8)	7/8"	(19.0)	560	(2.49)	4"	(100)	30	(13.6)
B3034-1/2	1/2"-13	1 13/16"	(46.0)	2 3/16"	(55.6)	1 3/16"	(30.2)	810	(3.60)	8"	(200)	47	(21.3)
B3034-5/8	5/8"-11	1 3/4"	(44.5)	2 1/8"	(54.0)	1 1/4"	(31.7)	1000	(4.45)	--	--	58	(26.3)
B3034-3/4	3/4"-10	2"	(50.8)	2 1/4"	(57.2)	1 1/4"	(31.7)	1500	(6.67)	--	--	77	(35.0)

**Note:** See page 27 for recommended setscrew torque.

All dimensions in charts and on drawings are in inches. Dimensions shown in parentheses are in millimeters unless otherwise specified.