

## Beam Clamps

### Beam Clamps — Malleable Iron, Silver Electroplated Finish

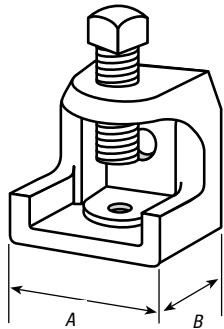

CAT. NO.	BASE SIZE (IN.)		JAW OPENING (IN.)	TAPPING OF BASE AND BACK HOLES	SET SCREW LOAD RATING <sup>†</sup>	TORQUE IN INCH-LBS.	STD. CTN.
	A	B					
500-SC	1	1¼	1⅞	¼-20	250	60	50
501	1½	1¾	⅞	⅝-18	500	60	50
502	2	2	1	⅝-16	750	120	50
503-SC	2½	2½	1	½-13	1,250	250	20
507	2½	2¾	1¾	½-13	1,250	250	20
508	2½	2¾	2½	½-13	1,250	250	10
509	1	1¼	1⅞	10-24	150	60	100
510	2⅞	1¾	⅞	¼-20	250	40	100
511-SC	2⅞	1¾	⅞	10-24	150	40	100

<sup>†</sup>Safety Factor of 3.

Load Ratings based on bottom hole of Beam Clamp.

CSA File No. LR-52208.

Also available in 316 stainless steel.

### U-540 — Side Hanger Clip

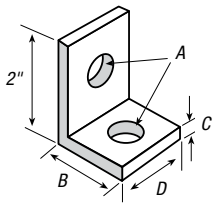

CAT. NO.	A (IN.)	B (IN.)	C (IN.)	D (IN.)	STD. CTN.
540 3/8	⅞	1⅞	¼	⅞	25
540 1/2 EC	⅞	1⅞	¼	1⅞	25
540-5/8	1⅞	2½	⅜	2	25
540-3/4	1⅞	2½	⅜	2	25

Finishes — GoldGalv® brand or Black (B)

### U-542 — Side Hanger Clip

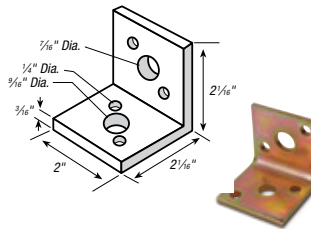

CAT. NO.	ROD SIZE	DESIGN LOAD (LBS.)
544	⅜"	610
	½"	1,000

Finishes — GoldGalv® brand or Black (B)  
Standard Finish — GoldGalv®, EG, HD, & SS available.

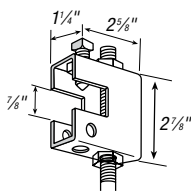

**U562**  
Beam Clamp  
½" set screw included.  
Rod Size: ½"  
Design load 500 lbs.

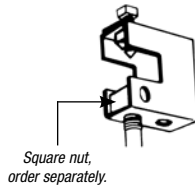

**U562**  
Beam Clamp Optional Use  
½" set screw included.  
Rod size: ½"  
Design load 800 lbs.  
For 20° swivel application, use ES-145-1/2 nut.

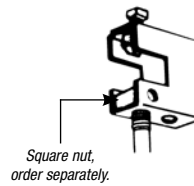

**U563**  
Beam Clamp Optional Use  
⅜" set screw included.  
Rod size: ⅜"  
Design load 400 lbs.

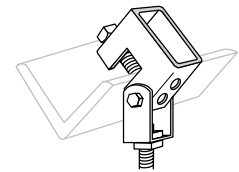

**U563**  
Beam Clamp with Swing Hanger  
⅜" set screw included.  
Rod sizes: ⅜"  
Design load 540 lbs.

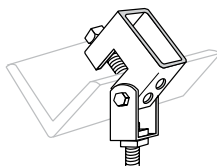

**U562**  
Beam Clamp with Swing Hanger  
½" screw included.  
Rod size: ½"  
Design load 800 lbs.

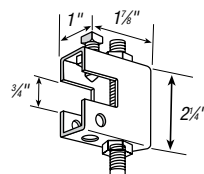

**U563**  
Beam Clamp  
⅜" set screw included.  
Rod size: ⅜"  
Design load 250 lbs.

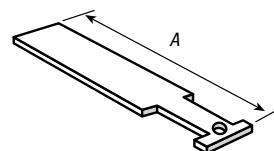

**U-568**  
Beam Clamp Safety Strap  
Standard Finish — GoldGalv® brand  
For U-563 beam clamp.

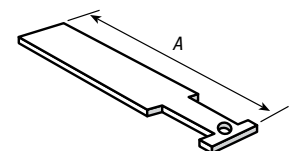

**U-568**  
Beam Clamp Safety Strap  
Standard Finish — GoldGalv® brand  
For U-562 beam clamp.

## Beam and Purlin Clamps

### Beam Clamps

- Supports threaded rod, threaded bridle rings and electrical boxes
- Bright zinc plating
- Supports 100 lbs. static load limit

#### Malleable Iron, Electro-Plated Finish

CAT. NO.	FIG. NO.	DESCRIPTION	STATIC LOAD LIMIT (LBS.)	STD. CTN.
BC1-TB	1	Steel beam clamp, 1/4"-20 threaded openings, fits flanges up to 3/8" thick	75	50
BC2-TB	1	Steel beam clamp, 3/16"-18 threaded openings, fits flanges up to 3/4" thick	320	50
510	2	Malleable iron beam clamp, 1/4"-20 threaded openings, fits flanges up to 3/8" thick	250	100
511-SC	2	Malleable iron beam clamp, 10-24 threaded openings, fits flanges up to 3/8" thick	250	100
500-SC	2	Malleable iron beam clamp, 1/4"-20 threaded openings, fits flanges up to 1 1/16" thick	250	50
509	2	Malleable iron beam clamp, 10-24 threaded openings, fits flanges up to 1 5/16" thick	150	100
501	2	Malleable iron beam clamp, 1 5/16"-18 threaded openings, fits flanges up to 7/8" thick	500	50
502	2	Malleable iron beam clamp, 3/8"-16 threaded openings, fits flanges up to 1" thick	750	25
503-SC	2	Malleable iron beam clamp, 1/2"-13 threaded openings, fits flanges up to 1" thick	1,250	20
507	2	Malleable iron beam clamp, 1/2"-13 threaded openings, fits flanges up to 1 3/8" thick	1,250	20
508	2	Malleable iron beam clamp, 1/2"-13 threaded openings, fits flanges up to 2 1/8" thick	1,250	10

Safety Factor of 3. Load Ratings based on bottom hole of Beam Clamp.  
CSA File No. LR-63683.

CAT. NO.	SIZE	TAPPED	DIMENSIONS (IN.)				STD. CTN.
			A	B	C	D	
BC1-TB	1	1/4-20	1 1/16	1 3/8	3/8	1 3/16	250
BC2-TB	2 15/16	3/8-16	2 7/8	2 1/8	3/4	1 1/16	25

Material: Steel. Finish: Zinc Plated.

#### Malleable Iron, Silver Electro-Plated Finish

CAT. NO.	BASE SIZE (IN.)		JAW OPENING (IN.)	TAPPING OF BASE AND BACK HOLES	LOAD RATING†	TORQUE IN INCH-LBS.	STD. CTN.
	A	B					
500-SC	1	1 1/4	1 1/16	1/4-20	250	60	50
501	1 1/2	1 3/8	7/8	3/16-18	500	60	50
502	2	2	1	3/8-16	750	125	25
503-SC	2 5/8	2 1/2	1	1/2-13	1,250	250	20
507	2 1/2	2 3/8	1 3/8	1/2-13	1,250	250	20
508	2 1/2	2 3/8	2 1/8	1/2-13	1,250	250	10
509	1	1 1/4	1 1/16	10-24	150	60	100
510	2 1/32	1 3/8	3/8	1/4-20	250	40	100
511-SC	2 7/32	1 3/8	3/8	10-24	150	40	100

†Safety Factor of 3. Load Ratings based on bottom hole of Beam Clamp.  
CSA File No. LR-63683.

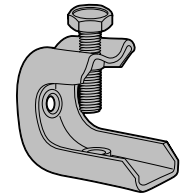
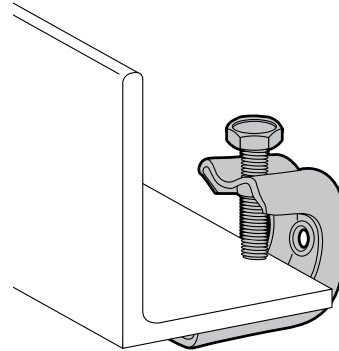

Fig. 1

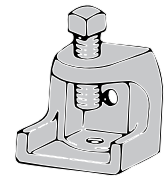
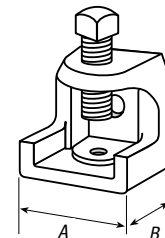
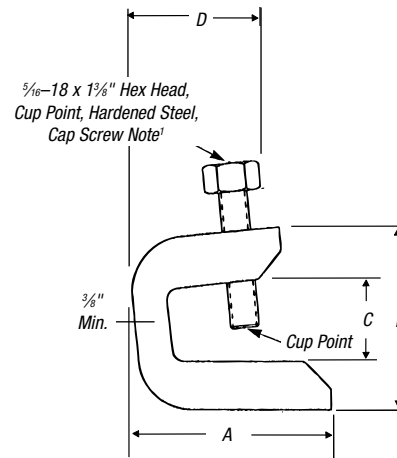

Fig. 2



500SS316, 502SS316 and 503SS316 in 316  
Stainless Steel also available.