

# CAST ALUMINUM Complete Units

Versatile weatherproof fixtures ideal for industrial, commercial and residential applications.

**DVAKS100CG**  
Ceiling Mount

**DVAKS200CG**  
Ceiling Mount - Lrg

**DVBKS100CG**  
Wall Mount

**DVCS100CG**  
Pendant Mount

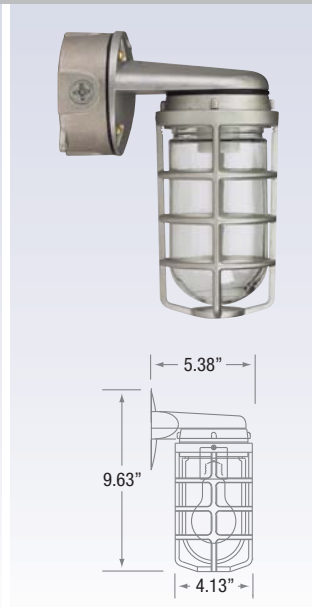

BOX	FITTER	SOCKET	GLOBE/LAMP	GUARD
Precision die cast aluminum with four 1/2" NPT plugs installed and one open 1/2" threaded conduit opening on the top.	Threaded, precision die cast aluminum with a silicone gasket between the wiring box and the fitter.	Porcelain, medium base with a nickle-plated screw shell.	Clear glass with threaded neck. Replacement glass part is GL100/GL200. Lamp not included.	Threaded die cast aluminum with a set screw for locking the guard in place.

## ORDERING INFO example: DVAKS100CG

SERIES	DESCRIPTION	INC	VOLTS	FINISH	GLASS
DVAKS100CG	Weatherproof Ceiling Mount	100W Max.	120V	Natural Aluminum	GL100 Replacement Glass Globe
DVAKS200CG	Weatherproof Ceiling Mount Large	200W Max.	120V	Natural Aluminum	GL200 Replacement Glass Globe
DVBKS100CG	Weatherproof Wall Mount	100W Max.	120V	Natural Aluminum	GL100 Replacement Glass Globe
DVCS100CG	Weatherproof Pendant Mount	100W Max.	120V	Natural Aluminum	GL100 Replacement Glass Globe

\* NOTE - Units are partially disassembled for easy installation.

