

Suspension Systems - NEMA 12, 13

Tara Plus Suspension System

Operator Interface Enclosure

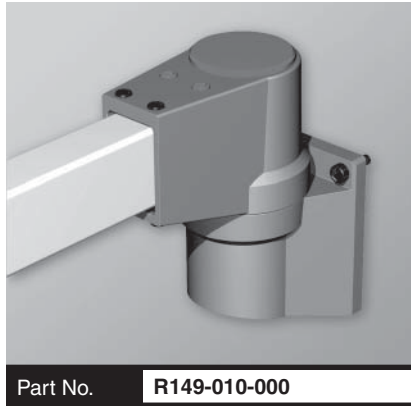

Part No. **R149-010-000**

Wall Joint

- Accepts 60x40mm rectangular tube perpendicular to its mounting surface.
- Die-cast Aluminum G Al Si 12.
- Rotates 186°.
- Accessible from the top.

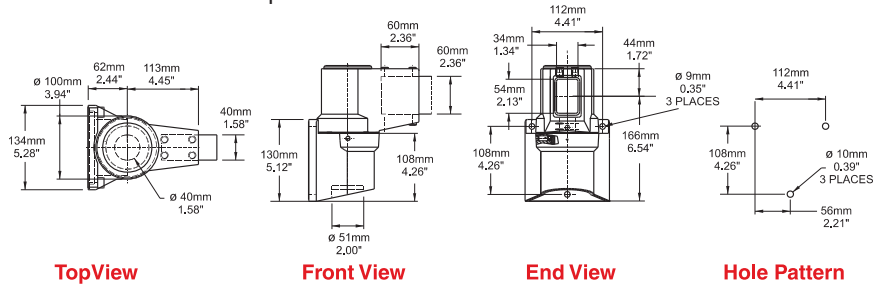

Part No. **R149-010-001**

Vertical Wall Joint

- Accepts 70mm tube parallel to its mounting surface.
- Die-cast Aluminum G Al Si 12.
- Rotates 316°.

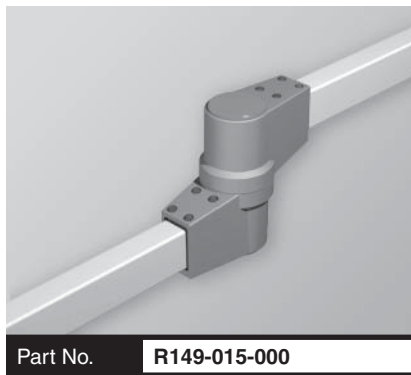
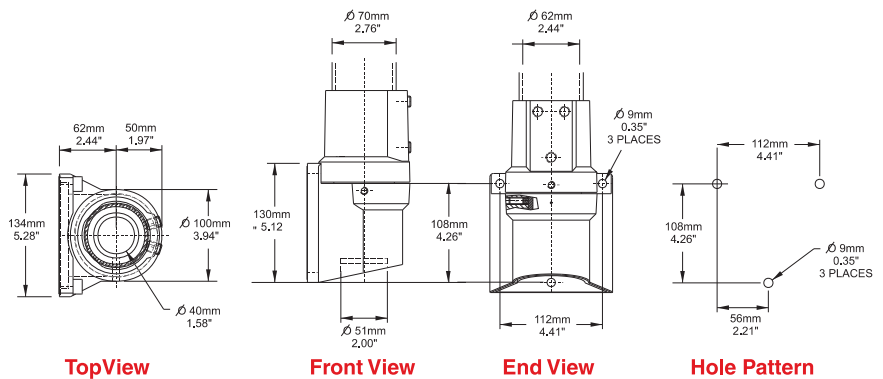

Part No. **R149-015-000**

Intermediate Joint

- Accepts 60x40mm rectangular tube.
- Die-cast Aluminum G Al Si 12.
- Integrated movement stop.
- One piece below.
- Rotates 300°.

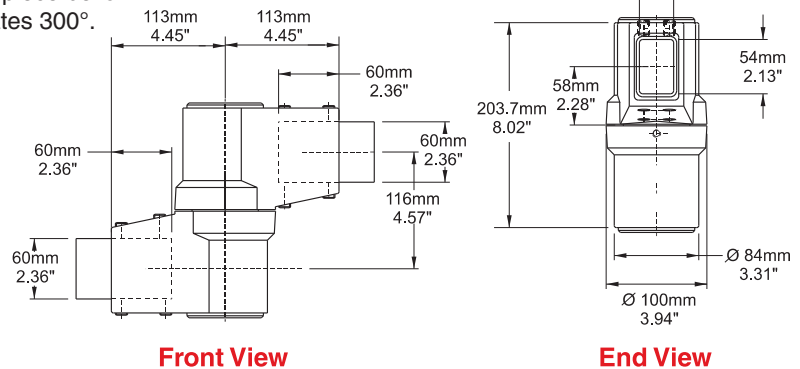

Suspension System

Technical references and CAD downloads available at www.hammondmfg.com

All dimensions in inches unless specified otherwise

Quality Products. Service Excellence.