

Standards and Certifications

Product

- IEC/EN 61800-5-1
- IEC/EN 61800-5-2
- UL 508C
- IEC 61508
- EN 62061
- EN ISO 13849-1

EMC

- Immunity: IEC/EN 61800-3
- Category C2

Certification

- UL
- cUL
- CE
- C-Tick
- RoHS
- EAC
- Plenum rated



Catalog Number Selection

Catalog Number Selection is for illustrative purposes only and not to be used to create new catalog numbers.

PowerXL Series—DG1 General Purpose Drive

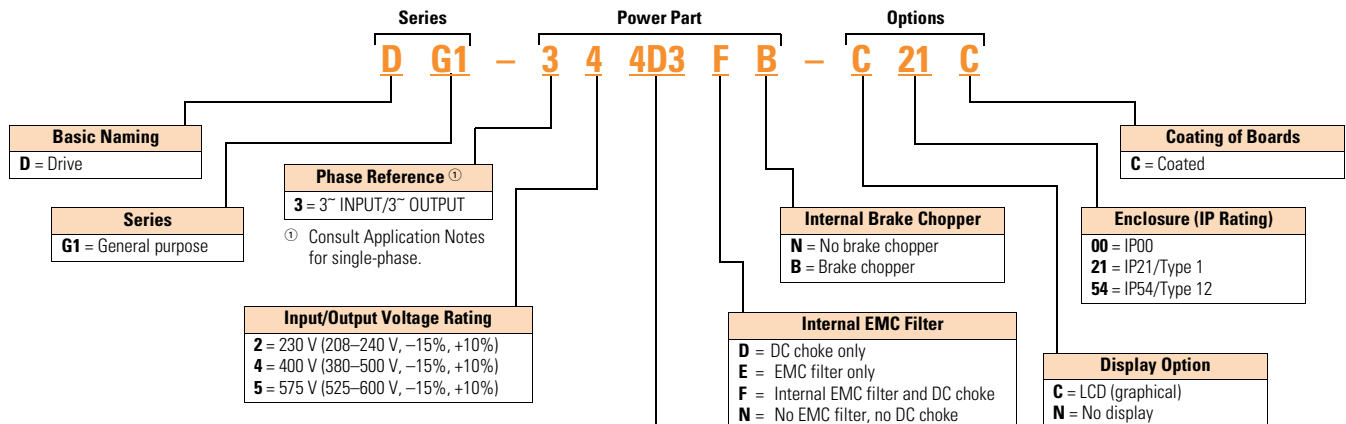

Output Current Rating (CT)		
208–240 V	380–500 V	525–600 V
3D7 = 3.7 A, 0.55 kW, 0.75 hp	2D2 = 2.2 A, 0.75 kW, 1 hp	3D3 = 3.3 A, 1.5 kW, 2 hp
4D8 = 4.8 A, 0.75 kW, 1 hp	3D3 = 3.3 A, 1.1 kW, 1.5 hp	4D5 = 4.5 A, 2.2 kW, 3 hp
6D6 = 6.6 A, 1.1 kW, 1.5 hp	4D3 = 4.3 A, 1.5 kW, 2 hp	7D5 = 7.5 A, 3.7 kW, 5 hp
7D8 = 7.8 A, 1.5 kW, 2 hp	5D6 = 5.6 A, 2.2 kW, 3 hp	010 = 10 A, 5.5 kW, 7.5 hp
011 = 11 A, 2.2 kW, 3 hp	7D6 = 7.6 A, 3 kW, 5 hp	013 = 13.5 A, 7.5 kW, 10 hp
012 = 12.5 A, 3 kW, 5 hp (VT)	9D0 = 9 A, 4 kW, 7.5 hp (VT)	018 = 18 A, 11 kW, 15 hp
017 = 17.5 A, 3.7 kW, 5 hp	012 = 12 A, 5.5 kW, 7.5 hp	022 = 22 A, 15 kW, 20 hp
025 = 25 A, 5.5 kW, 7.5 hp	016 = 16 A, 7.5 kW, 10 hp	027 = 27 A, 18 kW, 25 hp
031 = 31 A, 7.5 kW, 10 hp	023 = 23 A, 11 kW, 15 hp	034 = 34 A, 22 kW, 30 hp
048 = 48 A, 11 kW, 15 hp	031 = 31 A, 15 kW, 20 hp	041 = 41 A, 30 kW, 40 hp
061 = 61 A, 15 kW, 20 hp	038 = 38 A, 18 kW, 25 hp	052 = 52 A, 37 kW, 50 hp
075 = 75 A, 18.5 kW, 25 hp	046 = 46 A, 22 kW, 30 hp	062 = 62 A, 45 kW, 60 hp
088 = 88 A, 22 kW, 30 hp	061 = 61 A, 30 kW, 40 hp	080 = 80 A, 55 kW, 75 hp
114 = 114 A, 30 kW, 40 hp	072 = 72 A, 37 kW, 50 hp	100 = 100 A, 75 kW, 100 hp
143 = 143 A, 37 kW, 50 hp	087 = 87 A, 45 kW, 60 hp	125 = 125 A, 90 kW, 125 hp
170 = 170 A, 45 kW, 60 hp	105 = 105 A, 55 kW, 75 hp	144 = 144 A, 110 kW, 150 hp
211 = 211 A, 55 kW, 75 hp	140 = 140 A, 75 kW, 100 hp	208 = 208 A, 132 kW, 200 hp
248 = 248 A, 75 kW, 100 hp	170 = 170 A, 90 kW, 125 hp	
	205 = 205 A, 110 kW, 150 hp	
	245 = 245 A, 132 kW, 200 hp	

PowerXL Series—DG1 General Purpose Drive Option Boards

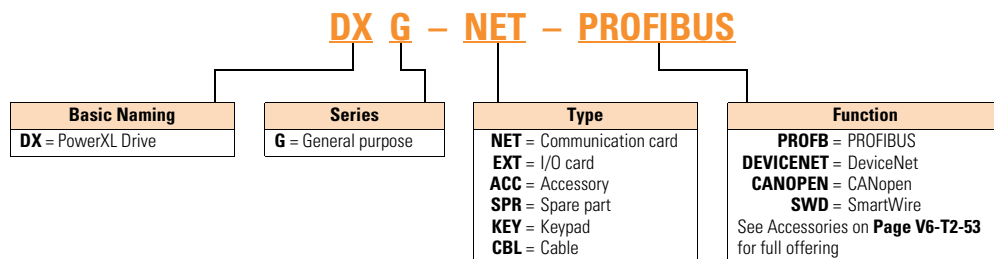

2.6

Adjustable Frequency Drives

PowerXL DG1 Series Drives

Frame 3

2

Description	230 V Catalog Number	480 V Catalog Number	575 V Catalog Number
Standard keypad	DXG-KEY-LCD	DXG-KEY-LCD	DXG-KEY-LCD
Main control board	DXG-SPR-CTRLBOARD	DXG-SPR-CTRLBOARD	DXG-SPR-CTRLBOARD
Control module kit with keypad ^①	DXG-SPR-CTRLKIT	DXG-SPR-CTRLKIT	DXG-SPR-CTRLKIT
Control board cover	DXG-SPR-BCOVER	DXG-SPR-BCOVER	DXG-SPR-BCOVER
Standard cover	DXG-SPR-FR3CVR	DXG-SPR-FR3CVR	DXG-SPR-FR3CVR
Main fan kit ^①	DXG-SPR-FR3FANKIT	DXG-SPR-FR3FANKIT	DXG-SPR-FR3FANKIT
Main fan	DXG-SPR-FR3FAN	DXG-SPR-FR3FAN	DXG-SPR-FR3FAN
Control fan	DXG-SPR-FR34CF	DXG-SPR-FR34CF	DXG-SPR-FR34CF
Bus capacitor	DXG-SPR-FR3BC	DXG-SPR-FR3BC	DXG-SPR-FR3BC
Main power board	DXG-SPR-2FR3MPB	DXG-SPR-4FR3MPB	DXG-SPR-4FR3MPB
EMI board	DXG-SPR-2FR3EB	DXG-SPR-4FR3EB	DXG-SPR-4FR3EB
Drive board	DXG-SPR-2FR3DB	DXG-SPR-4FR3DB	DXG-SPR-4FR3DB
Output board	DXG-SPR-FR3OB	DXG-SPR-FR3OB	DXG-SPR-FR3OB
Middle chassis cover	DXG-SPR-FR3MCC	DXG-SPR-FR3MCC	DXG-SPR-FR3MCC
Outer housing	DXG-SPR-FR3OH	DXG-SPR-FR3OH	DXG-SPR-FR3OH
UL conduit plate	DXG-SPR-FR3CPUL	DXG-SPR-FR3CPUL	DXG-SPR-FR3CPUL
IEC conduit plate	DXG-SPR-FR3CPIEC	DXG-SPR-FR3CPIEC	DXG-SPR-FR3CPIEC

Frame 4

Description	230 V Catalog Number	480 V Catalog Number	575 V Catalog Number
Standard keypad	DXG-KEY-LCD	DXG-KEY-LCD	DXG-KEY-LCD
Main control board	DXG-SPR-CTRLBOARD	DXG-SPR-CTRLBOARD	DXG-SPR-CTRLBOARD
Control module kit with keypad ^①	DXG-SPR-CTRLKIT	DXG-SPR-CTRLKIT	DXG-SPR-CTRLKIT
Control board cover	DXG-SPR-BCOVER	DXG-SPR-BCOVER	DXG-SPR-BCOVER
Standard cover	DXG-SPR-FR4CVR	DXG-SPR-FR4CVR	DXG-SPR-FR4CVR
Main fan kit ^①	DXG-SPR-FR4FANKIT	DXG-SPR-FR4FANKIT	DXG-SPR-FR4FANKIT
Main fan	DXG-SPR-FR4FAN	DXG-SPR-FR4FAN	DXG-SPR-FR4FAN
Control fan	DXG-SPR-FR34CF	DXG-SPR-FR34CF	DXG-SPR-FR34CF
Bus capacitor	DXG-SPR-2FR4BC	DXG-SPR-4FR24BC	DXG-SPR-4FR24BC
Main power board	DXG-SPR-2FR4MPB	DXG-SPR-4FR4MPB	DXG-SPR-4FR4MPB
EMI board	DXG-SPR-2FR4EB	DXG-SPR-4FR4EB	DXG-SPR-4FR4EB
Softstart board	DXG-SPR-2FR4SB	DXG-SPR-4FR4SB	DXG-SPR-4FR4SB
IGBT module	DXG-SPR-2FR4IGBT	DXG-SPR-4FR4IGBT	DXG-SPR-4FR4IGBT
Rectifier module	DXG-SPR-2FR4RM	DXG-SPR-4FR4RM	DXG-SPR-4FR4RM
Brake chopper module	DXG-SPR-2FR4BCM	DXG-SPR-4FR4BCM	DXG-SPR-4FR4BCM
Middle chassis cover	DXG-SPR-FR4MCC	DXG-SPR-FR4MCC	DXG-SPR-FR4MCC
Outer housing	DXG-SPR-FR4OH	DXG-SPR-FR4OH	DXG-SPR-FR4OH
UL conduit plate	DXG-SPR-FR4CPUL	DXG-SPR-FR4CPUL	DXG-SPR-FR4CPUL
IEC conduit plate	DXG-SPR-FR4CPIEC	DXG-SPR-FR4CPIEC	DXG-SPR-FR4CPIEC

Note

^① Factory recommended spare parts.