

Channel Nuts & Hardware



Channel Nuts

Channel nuts are one of the main components of our strut system. It is designed to provide essential gripping power and ease during installation. Channel nuts are press formed, machined and hardened from steel which meets the requirements of ASTM A108 or ASTM A36 for our larger sizes.

Bolts, Screws, and Nuts

All bolts, screws and nuts meet the physical and chemical requirements of ASTM A307, SAE J429 or ASTM A563, and have unified inch screw threads (coarse, UNC). ISO metric threads are also available on special request.

Recommended Torque

Special Note:
For recommended torque on 4Dimension trapeze hangers using B200 series square washers, see page 4D08.

Bolt Size	1/4"-20	5/16"-18	3/8"-16	1/2"-13
Foot/Lbs.	6	11	19	50
Nm	8	15	26	68

Bolt Size	M6x1	M8 x1.25	M10 x 1.5	M12x1.75
Nm	12	17	36	62
Foot/Lbs.	9	13	27	46

Materials & Finishes*

*Unless otherwise noted.
Note: Channel nuts are not available in HDG, Aluminum, or Stainless Steel Type 304

Finish Code	Finish	Specification
PLN	Plain	ASTM A108/A307 Gr. A, ASTM A563, SAE J429
ZN	Electro-Plated Zinc	ASTM B633 SC1 Type III
CZ	Chromium Zinc	ASTM F1136 Gr. 3
HDG	Hot-Dipped Galvanized	ASTM A153
SS6	Stainless Steel Type 316	MPIF 35/ASTM F593
AL	Aluminum	ASTM F468 S4

Metric

Metric dimensions are shown in parentheses. Unless noted, all metric dimensions are in millimeters.

Standard Channel Nuts

Numbering Example:

N 7 25 - (*) WO

Nut Type
 N = Standard Nut
 TN = Twirl-Nut™
 SN = Stud Nut
 STN = Stud Twirl-Nut™
 NW = Combo Nut Washer

Channel Type
 7 = Tall Channels
 B11
 B12
 2 = Medium Channels
 B22
 B24
 B26
 B32
 5 = Short Channels
 B42
 B52
 B54
 B56

Thread Size
 21 = #8-32
 22 = #10-24
 27 = #10-32
 24 = 1/4"-20
 23 = 5/16"-18
 28 = 3/8"-16
 26 = 7/16"-14
 25 = 1/2"-13
 55 = 5/8"-11
 75 = 3/4"-10
 78 = 7/8"-9

Stud Length
 * = Specify Length of stud below for Stud Nut or Twirl Stud Nuts
 3/4 = 3/4"
 1 = 1"
 1 1/4 = 1 1/4"
 1 1/2 = 1 1/2"

Suffix
 WO = Without Spring
 ___ = Twirl-Nut™ or nuts with springs have blank suffix

Metric Channel Nuts

Numbering Example:

BMS - 6 M

Nut Type
 BMS = Spring Nut
 BMS-D = Spring Nut (1/2" thick)
 BMT = Twirl-Nut™
 BMT-D = Twirl-Nut™ (1/2" thick)
 BMM = Spring Nut (Mini channel)

Metric Thread Size
 3 = M3.5
 4 = M4
 5 = M5
 6 = M6
 8 = M8
 10 = M10
 12 = M12

Suffix
 S = Short Spring
 M = Medium Spring
 L = Long Spring
 ___ = Twirl-Nut™ and nuts without springs have blank suffix

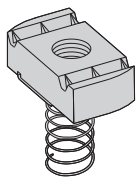

Spring Nut

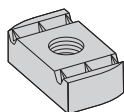

Nut without Spring

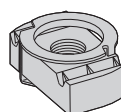

Twirl-Nut™

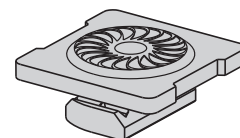

Combo Nut Washer

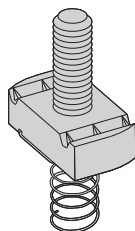

Stud Nut with Spring

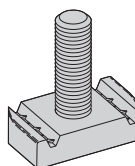

Stud Nut without Spring

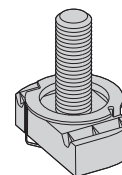

Twirl Stud Nut

Reference page 45 for general fitting and standard finish specifications.

Note: See page 51 for resistance to slip & page 52 for pull-out strength.

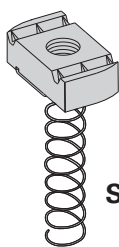

700 Series

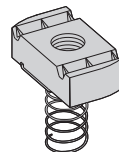

200 Series

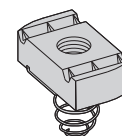

500 Series

Spring Nut

Part No.	Thread Size	Fits Channel Sizes	Nut Thickness		Wt./C	
			In.	mm	Lbs.	kg
N721	#8-32	B11 & B12	1/4"	(6.3)	7.0	(3.17)
N221	#8-32	B22, B24, B26, B32	1/4"	(6.3)	7.0	(3.17)
N521	#8-32	B42, B52, B54, B56	1/4"	(6.3)	7.0	(3.17)
N727	#10-32	B11 & B12	1/4"	(6.3)	7.0	(3.17)
N227	#10-32	B22, B24, B26, B32	1/4"	(6.3)	7.0	(3.17)
N527	#10-32	B42, B52, B54, B56	1/4"	(6.3)	7.0	(3.17)
N722	#10-24	B11 & B12	1/4"	(6.3)	7.0	(3.17)
N222	#10-24	B22, B24, B26, B32	1/4"	(6.3)	7.0	(3.17)
N522	#10-24	B42, B52, B54, B56	1/4"	(6.3)	7.0	(3.17)
N724	1/4-20	B11 & B12	1/4"	(6.3)	6.7	(3.04)
N224	1/4-20	B22, B24, B26, B32	1/4"	(6.3)	6.7	(3.04)
N524	1/4-20	B42, B52, B54, B56	1/4"	(6.3)	6.7	(3.04)
N723	5/16-18	B11 & B12	1/4"	(6.3)	6.7	(3.04)
N223	5/16-18	B22, B24, B26, B32	1/4"	(6.3)	6.7	(3.04)
N523	5/16-18	B42, B52, B54, B56	1/4"	(6.3)	6.7	(3.04)
N728	3/8-16	B11 & B12	3/8"	(9.5)	9.3	(4.22)
N228	3/8-16	B22, B24, B26, B32	3/8"	(9.5)	9.3	(4.22)
N528	3/8-16	B42, B52, B54, B56	3/8"	(9.5)	9.3	(4.22)
N726	7/16-14	B11 & B12	3/8"	(9.5)	8.8	(3.99)
N226	7/16-14	B22, B24, B26, B32	3/8"	(9.5)	8.8	(3.99)
N526	7/16-14	B42, B52, B54, B56	3/8"	(9.5)	8.8	(3.99)
N725	1/2-13	B11 & B12	1/2"	(12.7)	11.6	(5.26)
N225	1/2-13	B22, B24, B26, B32	1/2"	(12.7)	11.6	(5.26)
N525	1/2-13	B42, B52, B54, B56	3/8"	(9.5)	8.8	(3.99)
N755	5/8-11	B11 & B12	1/2"	(12.7)	16.4	(7.44)
N255	5/8-11	B22, B24, B26, B32	1/2"	(12.7)	16.4	(7.44)
N555	5/8-11	B42, B52, B54, B56	3/8"	(9.5)	10.2	(4.62)
N775	3/4-10	B11 & B12	1/2"	(12.7)	14.5	(6.58)
N275	3/4-10	B22, B24, B26, B32	1/2"	(12.7)	14.5	(6.58)
N575	3/4-10	B42, B52, B54, B56	3/8"	(9.5)	8.8	(3.99)
N778	7/8-9	B11 & B12	1/2"	(12.7)	12.5	(5.67)
N278	7/8-9	B22, B24, B26, B32	1/2"	(12.7)	12.5	(5.67)

Metric Threads

BMS-6L	M6 x 1	B11 & B12	1/4"	(6.3)	6.9	(3.13)
BMS-6M	M6 x 1	B22, B24, B26, B32	1/4"	(6.3)	6.9	(3.13)
BMS-6S	M6 x 1	B42, B52, B54, B56	1/4"	(6.3)	6.9	(3.13)
BMS-8L	M8 x 1.25	B11 & B12	1/4"	(6.3)	6.7	(3.04)
BMS-8M	M8 x 1.25	B22, B24, B26, B32	1/4"	(6.3)	6.7	(3.04)
BMS-8S	M8 x 1.25	B42, B52, B54, B56	1/4"	(6.3)	6.7	(3.04)
BMS-10L	M10 x 1.5	B11 & B12	3/8"	(9.5)	9.6	(4.35)
BMS-10M	M10 x 1.5	B22, B24, B26, B32	3/8"	(9.5)	9.6	(4.35)
BMS-10S	M10 x 1.5	B42, B52, B54, B56	3/8"	(9.5)	9.6	(4.35)
BMS-12M	M12 x 1.75	B22, B24, B26, B32	3/8"	(9.5)	9.2	(4.17)
BMS-12S	M12 x 1.75	B42, B52, B54, B56	3/8"	(9.5)	9.2	(4.17)
BMS-D-12L	M12 x 1.75	B11 & B12	1/2"	(12.7)	12.2	(5.53)
BMS-D-12M	M12 x 1.75	B22, B24, B26, B32	1/2"	(12.7)	12.2	(5.53)

Note: For mini channel nut information see page 204.

Reference page 45 for general fitting and standard finish specifications.

Channel Nuts

Resistance To Slip

- With Safety Factor of 3

Thread Size	Nut Part Numbers	Resistance to Slip					
		12 ga. Channel		14 ga. Channel		16 ga. Channel	
		Lbs.	N	Lbs.	N	Lbs.	N
#8-32	N221, N221WO, N521, N721, TN221	50	220	50	220	50	220
#10-24	N222, N222WO, N522, N722, TN222	100	440	100	440	100	440
#10-32	N227, N227WO, N527, N727, TN227	100	440	100	440	100	440
1/4"-20	NW524*, N224, N224WO, N524, N724, TN224, STN224, SN224WO, SN224, SN524, SN724	300	1330	300	1330	300	1330
5/16"-18	N223, N223WO, N523, N723, TN223	450	2000	450	2000	450	2000
3/8"-16	NW528*, N228, N228WO, N528, N728, TN228, STN228, SN228WO, SN228, SN528, SN728	800	3560	600	2670	600	2670
7/16"-14	N226, N226WO, N526, N726, TN226	1000	4450	800	3560	800	3560
1/2"-13	N225, N225WO, N725, TN225, STN225, SN225WO, SN225, SN725	1500	6670	1000	4450	1000	4450
	NW525*, N525, N525WO, TN525, STN525, SN525WO, SN525	1500	6670	1000	4450	1000	4450
5/8"-11	N255, N255WO, N755, TN255	1500	6670	1000	4450	1000	4450
	N555, N555WO	1500	6670	1000	4450	1000	4450
3/4"-10	N275, N275WO, N775	1500	6670	1000	4450	1000	4450
	N575, N575WO	1500	6670	1000	4450	1000	4450
7/8"-9	N278, N278WO, N778	1500	6670	1000	4450	1000	4450
M6 x 1	BMS-6, BMS-6L, BMS-6M, BMS-6S, BMT-6	300	1330	300	1330	300	1330
M8 x 1.25	BMS-8, BMS-8L, BMS-8M, BMS-8S, BMT-8	450	2000	450	2000	450	2000
M10 x 1.50	BMS-10, BMS-10L, BMS-10M, BMS-10S, BMT-10	800	3560	600	2760	600	2760
M12 x 1.75	BMS-D-12, BMS-D-12L, BMS-D-12M, BMT-D-12	1500	6670	1000	4450	1000	4450
	BMS-12, BMS-12M, BMS-12S, BMT-12	1500	6670	1000	4450	1000	4450

* Combo Nut Washer (see page 50)

Note:

Using stainless steel channel nuts in stainless steel channel, reduce slip loads by 50% due to hardness of material.
Using stainless steel channel nuts in aluminum channel, reduce slip loads by 70% due to hardness of material.

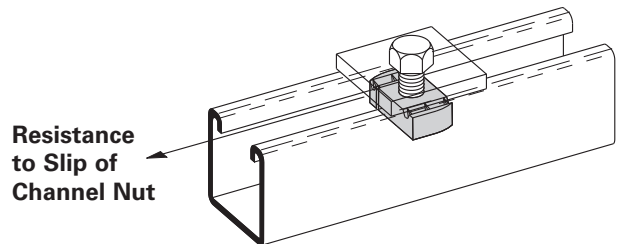

Note: For mini channel nut information see page 204.

Pull-Out Strength

- With Safety Factor of 3
- Maximum pullout strength for B11 & B12 channels is limited to 1500 lbs. (6670 N).

Thread Size	Nut Part Numbers	Pull-Out Strength					
		12 ga. Channel		14 ga. Channel		16 ga. Channel	
		Lbs.	N	Lbs.	N	Lbs.	N
#8-32	N221, N221WO, N521, N721, TN221	200	890	200	890	200	890
#10-24	N222, N222WO, N522, N722, TN222	250	1110	250	1110	250	1110
#10-32	N227, N227WO, N527, N727, TN227	250	1110	250	1110	250	1110
1/4"-20	NW524*, N224, N224WO, N524, N724, TN224, STN224, SN224WO, SN224, SN524, SN724	450	2000	450	2000	450	2000
5/16"-18	N223, N223WO, N523, N723, TN223	750	3330	750	3330	750	3330
3/8"-16	NW528*, N228, N228WO, N528, N728, TN228, STN228, SN228WO, SN228, SN528, SN728	1100	4890	1000	4450	1000	4450
7/16"-14	N226, N226WO, N526, N726, TN226	1500	6670	1200	5340	1000	4450
1/2"-13	N225, N225WO, N725, TN225, STN225, SN225WO, SN225, SN725	2000	8900	1400	6230	1000	4450
	NW525*, N525, N525WO, TN525, STN525, SN525WO, SN525	1500	6670	1400	6230	1000	4450
5/8"-11	N255, N255WO, N755, TN255	2000	8900	1400	6230	1000	4450
	N555, N555WO	1500	6670	1400	6230	1000	4450
3/4"-10	N275, N275WO, N775	2000	8900	1400	6230	1000	4450
	N575, N575WO	1500	6670	1400	6230	1000	4450
7/8"-9	N278, N278WO, N778	1500	6670	1400	6230	1000	4450
M6 x 1	BMS-6, BMS-6L, BMS-6M, BMS-6S, BMT-6	450	2000	450	2000	450	2000
M8 x 1.25	BMS-8, BMS-8L, BMS-8M, BMS-8S, BMT-8	750	3330	750	3330	750	3330
M10 x 1.50	BMS-10, BMS-10L, BMS-10M, BMS-10S, BMT-10	1100	4890	1000	4450	1000	4450
M12 x 1.75	BMS-D-12, BMS-D-12L, BMS-D-12M, BMT-D-12	2000	8900	1400	6230	1000	4450
	BMS-12, BMS-12M, BMS-12S, BMT-12	1500	6670	1400	6230	1000	4450

Channel Nuts & Hardware
Metric Threads

* Combo Nut Washer (see page 50)

Note:

Using stainless steel channel nuts in stainless steel channel, use pull-out loads as shown above.

Using stainless steel channel nuts in aluminum channel, reduce pull-out loads by 70% due to hardness of material.

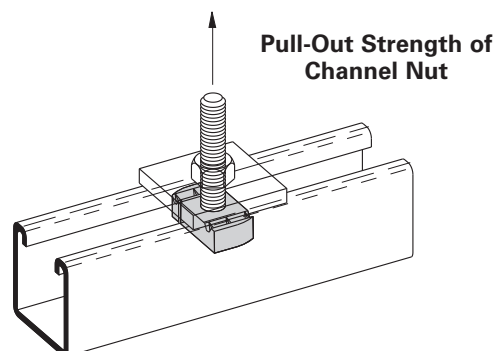

Note: For mini channel nut information see page 204.

Reference page 45 for general fitting and standard finish specifications.