

# Fittings

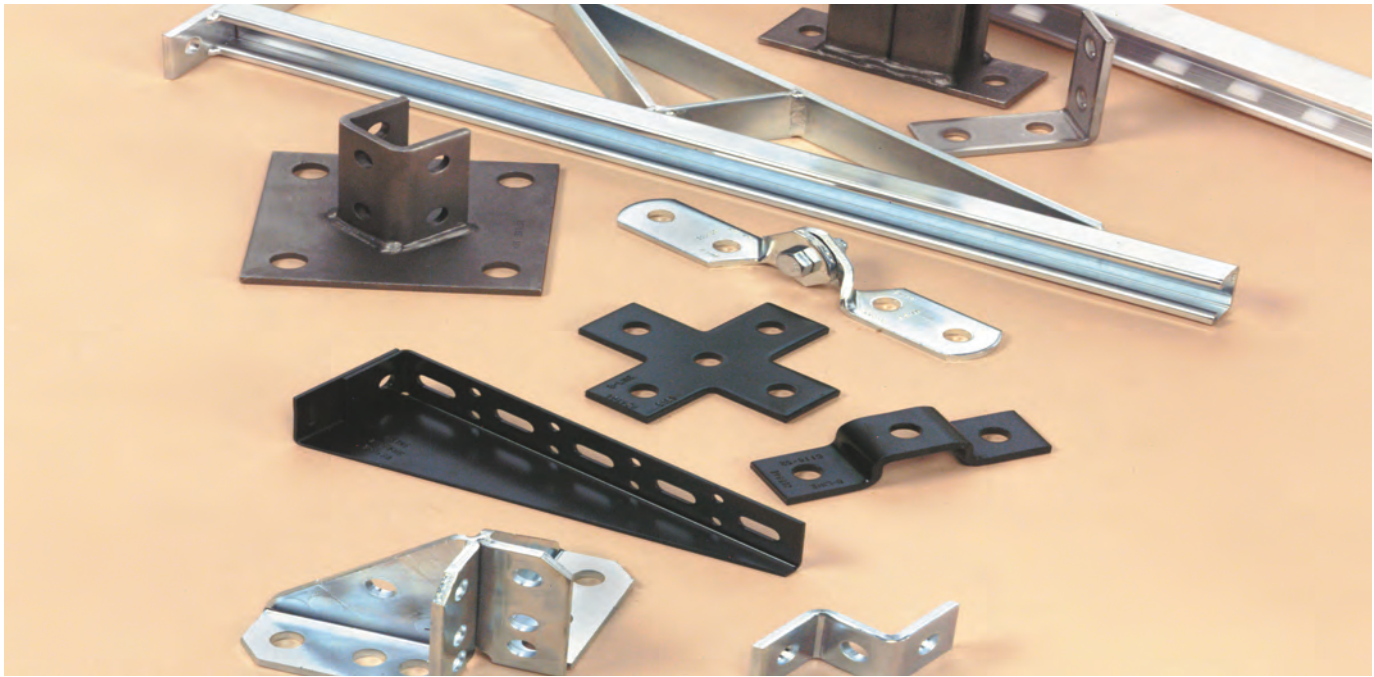

This section offers a full selection of fittings and accessories to complete our strut system. Fittings are made from hot rolled, pickled and oiled plate or strip steel in accordance with ASTM A1018 33,000 PSI min. yield, unless noted.

## Dimensions

The following dimensions apply to all fittings except as noted:

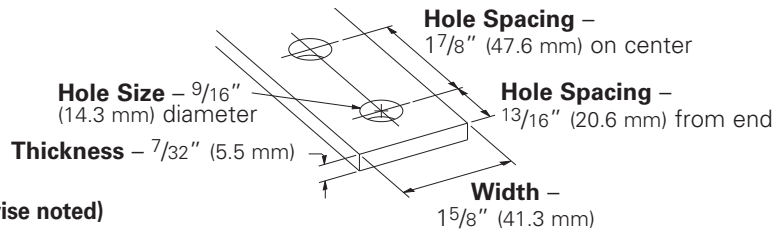

## Materials & Finishes (Unless otherwise noted)

Finish Code	Finish	Specification
PLN	Plain	ASTM A1018 33,000 PSI min. yield
ZN	Electro-Plated Zinc	ASTM B633 SC3 Type III or ASTM A653
GRN	DURA GREEN™	
HDG	Hot-Dipped Galvanized	ASTM A123
SS4	Stainless Steel Type 304	ASTM A240
SS6	Stainless Steel Type 316	ASTM A240
AL	Aluminum	ASTM B209

Note: A minimum order may apply on special material and finishes.

## Hardware

Nuts and bolts are not included with the fittings and must be ordered separately, unless noted.

## Pre-Assembled Fittings

Some fittings are available with hex head cap screws and channel nuts pre-assembled. These fittings and finishes will be flagged using the following symbol.



**PA** <sup>ZN</sup>  
GRN

## Metric

Metric dimensions are shown in parentheses. Unless noted, all metric dimensions are in millimeters.

## Load Data

The load data published includes safety factor of 2.5 when used with 12 ga. (2.6) channel (safety factor = ratio of ultimate load to the design load).

Use 1/2"-13 x 7/8" hex head cap screws and 1/2"-13 (N225 or TN225) channel nuts for the rated results.

## Recommended Bolt Torque

Bolt Size	1/4"-20	5/16"-18	3/8"-16	1/2"-13
Foot/Lbs.	6	11	19	50
Nm	8	15	26	68

See chart on page 113 for setscrew torque.

## 4Dimension™ Strut System Compatible

These fittings and finishes will be flagged using the following symbol.



## B376 Four Bearing Trolley Assembly

- Safety Factor of 2.5
- Stainless steel ball bearings
- Not for continuous cycling applications
- Standard finishes: ZN
- Wt./C 110 Lbs. (49.9 kg)

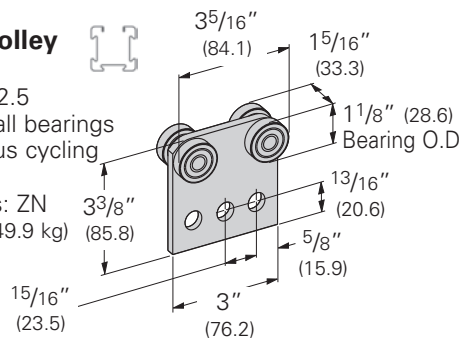

Design Load in B22		
Lbs.	kN	RPM
300	(1.33)	@600
450	(2.00)	@300
600	(2.67)	@100

Design Load

## B377 Two Bearing Trolley Assembly

- Safety Factor of 2.5
- Stainless steel ball bearings
- Not for continuous cycling applications
- Standard finishes: ZN
- Wt./C 48 Lbs. (21.8 kg)

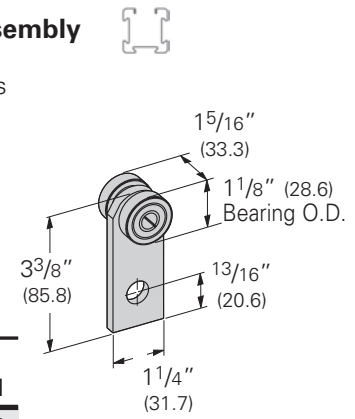

Design Load in B22		
Lbs.	kN	RPM
150	(.67)	@600
225	(1.00)	@300
437	(1.94)	@100

Design Load

## B477 Two Bearing Light Duty Trolley Assembly

- Design Load 50 Lbs. (.22 kN)
- Safety Factor of 2.5
- Stainless steel ball bearings
- Not for continuous cycling applications
- Material: 12 Gauge (2.6) ASTM A1011 33,000 PSI min. yield
- Standard finishes: ZN
- Wt./C 30 Lbs. (13.6 kg)

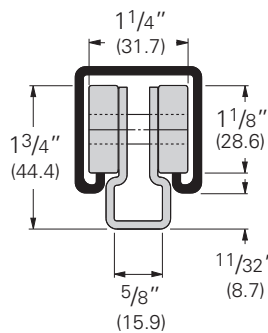

## B477P With Plastic Bearings

- Design Load 10 Lbs. (.045 kN)

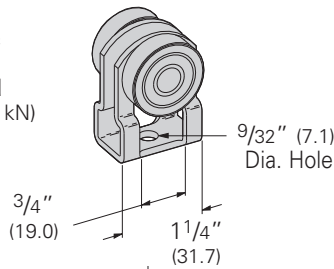

Design Load

## B478 Four Bearing Light Duty Trolley Assembly

- Design Load 100 Lbs. (.44 kN)
- Safety Factor of 2.5
- Stainless steel ball bearings
- Not for continuous cycling applications
- Material: 12 Gauge (2.6) ASTM A1011 33,000 PSI min. yield
- Standard finishes: ZN
- Wt./C 68 Lbs. (30.8 kg)

## B478P With Plastic Bearings

- Design Load 20 Lbs. (.090 kN)

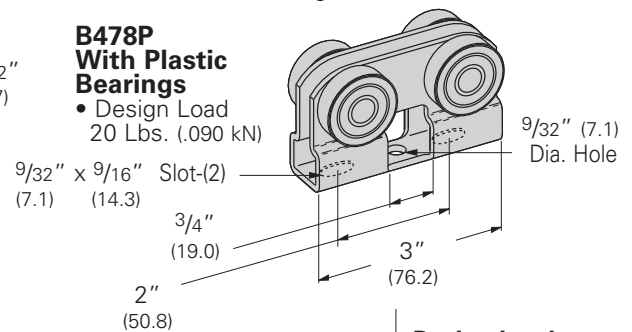

Design Load

## B477H Two Bearing Light Duty Trolley Assembly with Eye Hook

- Design Load 50 Lbs. (.22 kN)
- Safety Factor of 2.5
- Stainless steel ball bearings
- Not for continuous cycling applications
- Material: 12 Gauge (2.6) ASTM A1011 33,000 PSI min. yield
- Standard finishes: ZN
- Wt./C 36 Lbs. (16.3 kg)

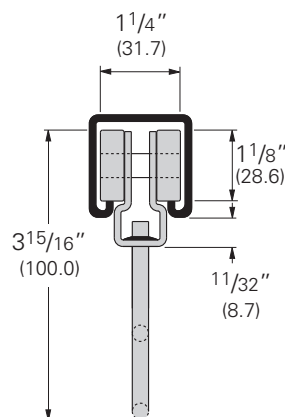

## B477HP With Plastic Bearings

- Design Load 10 Lbs. (.045 kN)

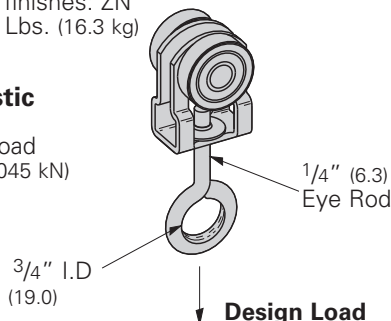

Design Load

## B478H Four Bearing Light Duty Trolley Assembly with Eye Hook

- Design Load 100 Lbs. (.44 kN)
- Safety Factor of 2.5
- Stainless steel ball bearings
- Not for continuous cycling applications
- Material: 12 Gauge (2.6) ASTM A1011 33,000 PSI min. yield
- Standard finishes: ZN
- Wt./C 72 Lbs. (32.6 kg)

## B478HP With Plastic Bearings

- Design Load 20 Lbs. (.090 kN)

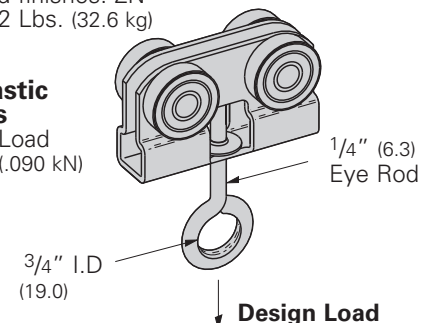

Design Load

4Dimension compatible fitting

Reference page 73 for general fitting and standard finish specifications.