



**Application:**

Type 1 enclosure designed for indoor use to run electrical wiring

**Construction:**

- 16 steel gauge
- Joiner supplied with each length
- Retractable sealing hasp
- ANSI/ASA61 grey polyester - epoxy textured powder coating inside out

**Also Available:**

- Heavier gauge for larger than 6" x 6" wireways
- Factory installed wire separating barriers (specify if horizontal or vertical installation inside fitting)
- Cutouts & holes, special finishes & sizes

**Standards:**

- CSA certified 150359

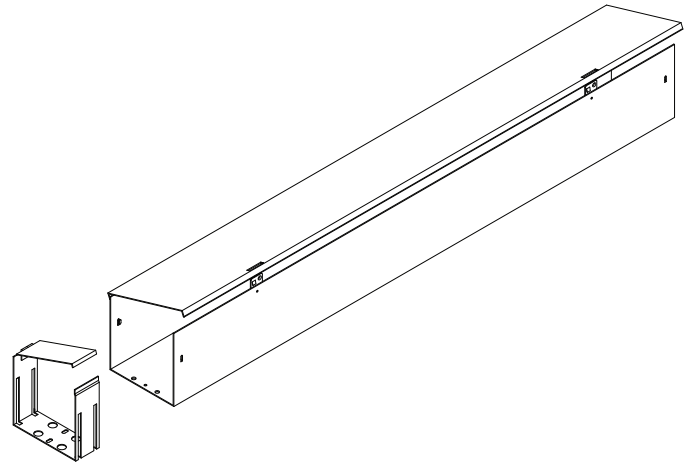

CAPACITY CHART

Wire Sizes	Dimension of Wires		Maximum Number of Wires of Same Capacity					
	Types	Types	64mm x 64mm (2.5" x 2.5")		102mm x 102mm (4" x 4")		152mm x 152mm (6" x 6")	
	RW75 R90 RW75 (X-Link) RW90 (X-Link)	T, TW, TWH RW75 (X-Link) RW90 (X-Link)	A	B	A	B	A	B
14	.0327	.0135	38	92	97	200	200	200
12	.0384	.0172	32	72	83	186	187	200
10	.0460	.0224	27	55	69	142	156	200
8	.0760	.0475	16	26	42	67	94	151
6	.1238	.0819	10	15	25	39	58	87
4	.1605	.1087	7	11	19	29	44	66
3	.1817	.1263	6	9	17	25	39	57
2	.2067	.1473	6	8	15	21	34	48
1	.2715	.2027	4	6	11	15	26	35
0	.3107	.2367	4	5	10	13	23	30
00	.3578	.2781	3	4	8	11	20	25
000	.4151	.3288	3	3	7	9	17	21
0000	.4840	.3904	2	3	6	8	14	18
250MCM	.5917	.4877	2	2	5	6	12	14
300MCM	.6837	.5581	1	2	4	5	10	12
350MCM	.7620	.6291	1	1	4	5	9	11
400MCM	.8365	.6969	1	1	3	4	8	10
500MCM	.9834	.8316	1	1	3	3	7	8
600MCM	1.1940	1.0261	1	1	2	3	6	7
700MCM	1.3355	1.1575	-	1	2	2	5	6
750MCM	1.4082	1.2252	-	1	2	2	5	5

**TECHNICAL READOUT**

Description	Catalog No. Weight		Catalog No. Weight		Catalog No. Weight	
	2.5" x 2.5"	lbs.	4" x 4"	lbs.	6" x 6"	lbs.
12" Wireway Section	<b>B21LD</b>	2	<b>B41LD</b>	4	<b>B61LD</b>	5
24" Wireway Section	<b>B22LD</b>	4	<b>B42LD</b>	7	<b>B62LD</b>	10
60" Wireway Section	<b>B25LD</b>	11	<b>B45LD</b>	18	<b>B65LD</b>	26
96" Wireway Section	<b>B28LD</b>	20	<b>B48LD</b>	33	<b>B68LD</b>	49

**ACCESSORIES**

90° Elbow	<b>B290E</b>	1.25	<b>B490E</b>	2	<b>B690E</b>	4
45° Elbow	<b>B245E</b>	1.25	<b>B445E</b>	1.50	<b>B645E</b>	2.5
22.5° Elbow	<b>B225E</b>	1	<b>B425E</b>	1.5	<b>B625E</b>	2
Tee Fitting	<b>B2T</b>	1.5	<b>B4T</b>	2.5	<b>B6T</b>	4
Cross Fitting	<b>B2CF</b>	2	<b>B4CF</b>	2.25	<b>B6CF</b>	4
Hanger (hori. & vert.)	<b>B2H</b>	0.25	<b>B4H</b>	0.5	<b>B6H</b>	0.75
Closing Plate	<b>B2CP</b>	0.25	<b>B4CP</b>	0.5	<b>B6CP</b>	1
Adaptor	<b>B2AD</b>	0.25	<b>B4AD</b>	0.75	<b>B6AD</b>	1
Reducer 4" to 2.5"	-	-	<b>B42R</b>	1.5	-	-
Reducer 6" to 4"	-	-	-	-	<b>B64R</b>	2
Joiner	<b>B2J</b>	0.25	<b>B4J</b>	0.5	<b>B6J</b>	0.75
12" Barrier*	<b>B21B</b>	0.5	<b>B41B</b>	1	<b>B61B</b>	1
24" Barrier*	<b>B22B</b>	1	<b>B42B</b>	2	<b>B62B</b>	3
60" Barrier*	<b>B25B</b>	3	<b>B45B</b>	5	<b>B65B</b>	7
96" Barrier*	<b>B28B</b>	5	<b>B48B</b>	9	<b>B68B</b>	14

\* Barrier designed for field installation





# B..LD Series

## EEMAC / NEMA 1

### Lay-In Wireway and Accessories

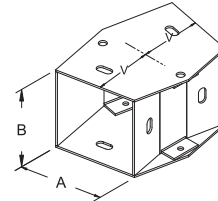
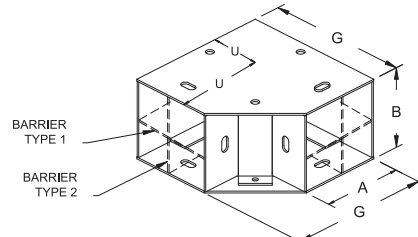
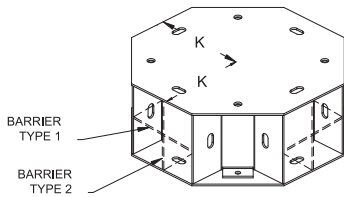
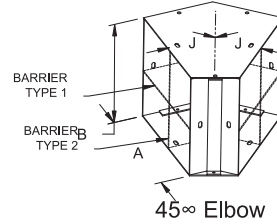
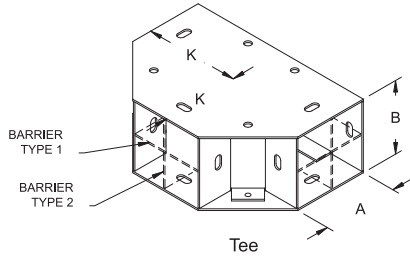

Cross

90° Elbow

22 1/2° Elbow

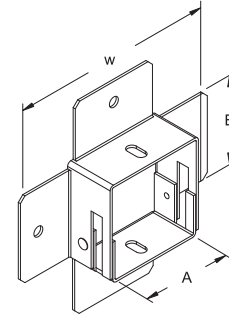
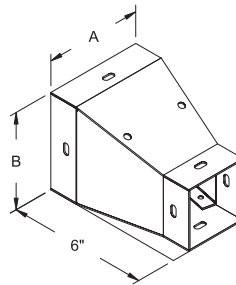
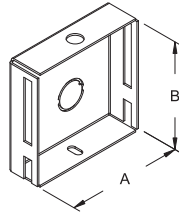
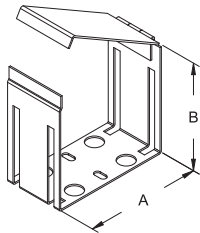

Joiner

Closing plate

Reducer

Adaptor

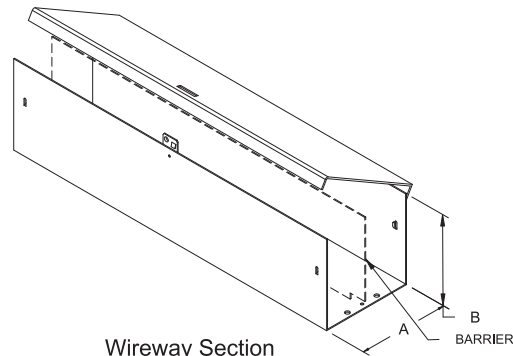
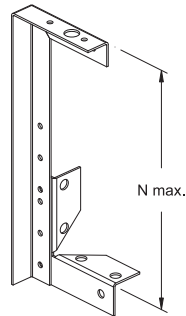
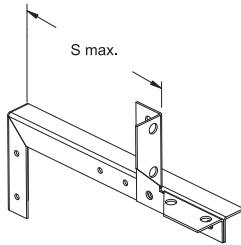

Hanger horizontally mounted

Hanger vertically mounted

Wireway Section

#### DUCT SIZE

A	B	G	J	K	N	S	U	V	W	X	Y
2.500	x 2.500	4.625	2.406	3.313	7.500	6.250	3.313	2.063	5.188	-	-
4.000	x 4.000	6.125	2.688	4.063	9.500	7.125	4.063	2.156	6.888	2.500	2.500
6.000	x 6.000	8.125	3.094	5.063	14.000	9.500	5.063	2.375	8.688	4.000	4.000