

60 Hz Core & Coil Ballasts

High Pressure Sodium



Input Volts	Catalog† Number	Circuit Type	Input Watts	Max Input Current	Nom Open Circuit Voltage	Fuse Rating (Amps)	Wiring Dia	Dimensions			Non-PCB Capacitor (Page 7-37 & 7-38)				Total Weight (lbs)	Ignitor †† (Page 7-39 to 7-43)		U.L. Bench Top Rise Code 1029 (pg 7-3)
											Mfd	Min Volt	Cap Catalog Number	Dry or Oil		Part Number	Max Dist To Lamp (ft)	
								Fig	A	B								
70W Lamp, ANSI Code S62																		
120	71A7907-600 71A7907-500D	R-NPF R-HPF	86	2.1 1.3	120	8 3	G	9	1.3	2.5	—	—	-----	—	2.0	LI551-H4	2	A
120	71A7907-600B 71A7907-001DB	R-NPF R-HPF	86	2.1 1.3	120	8 3	H	9	1.3	2.9	—	—	-----	—	2.0	Integral Ignitor	2	A
480	71A7941-500D	HX-HPF	93	.4	120	2	K	1	1.9	3.2	7	300	7C070L30RA	D	6.5	LI551-H4	2	A
120/208 240/277	71A7991-500D	HX-HPF	96	1.4/.9 .8/.7	120	5/3/ 2/2	K	14	1.5	2.9	7	300	7C070L30RA	D	5.6	LI551-H4	2	B/C/ B/C
120/208 240/277	71A7971-001D	HX-HPF	96	1.4/.9 .8/.7	120	5/3/ 2/2	K	14	1.5	2.9	7	300	7C070L30RA	D	5.6	LI551-H4	2	B/C/ B/C
120/ 277/347	71A79A1-500D 71A79A1-001D	HX-HPF	93	1.4/ .7/.6	120	5/ 2/2	K	1	1.5	3.1	7	300	7C070L30RA	D	5.5	LI551-H4	2	A/ B/A
127/220	71A79H8-500DMLA	CWA	100	.8/.47	108	2/2	M	14	1.7	3.1	32.5	300	7C325P30RA	D	5.1	LI551-J4	2	B/C NOM
230	71A79J3-500D	CWA	98	0.45	110	2	M	14	1.6	3.0	28	170	7C280P30RA	D	5.7	LI551-H4	2	C
120/277	71A7988-500D	CWA	95	.9/.4	105	3/1	M	1	1.5	2.8	32.5	300	7C325P30-RA	D	5.5	LI551-J4	2	A/D
120/ 208/240	71A79E6-500D	CWI	95	.9/ .5/.5	110	3/ 2/2	V	1	1.6	2.9	24	300	7C240P30RA	D	5.8	LI551-J4	2	C C/B

† Ordering information:

Replacement/retrofit ballast kits – indicated by bold type and -001D or -001 suffix. Refer to pages 7-4 to 7-9 for more information on replacement kits.

Original equipment ballasts – typically ordered with capacitor (as shown).

- 500D includes core & coil with dry-film capacitor.
- 500 includes core & coil with oil-filled capacitor (required for higher wattage ballasts).

May also be available with welded bracket, and/or without capacitor:

- 510D includes core & coil with welded bracket and dry-film capacitor.
- 510 includes core & coil with welded bracket and oil-filled capacitor.
- 600 core & coil only (no capacitor).
- 610 core & coil with welded bracket (no capacitor).

†† Each ballast requiring an ignitor is furnished standard with a short-range ignitor model shown for use within fixtures. Long-range ignitors are available separately if required. See pages 7-39 to 7-43 for additional information.

- **Maximum Input Current** – For HX and R circuits, value is the highest of starting, operating or open circuit current. For CWA, SCWA and CWI circuits, value is the operating current.

NOM Certified ballast available for Mexican market. Add "ML" to suffix (example: -500DML). Ballasts are branded Philips.

Canadian replacement/retrofit ballast kit indicated by bold type. Refer to page 7-8.

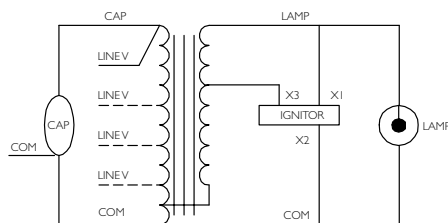
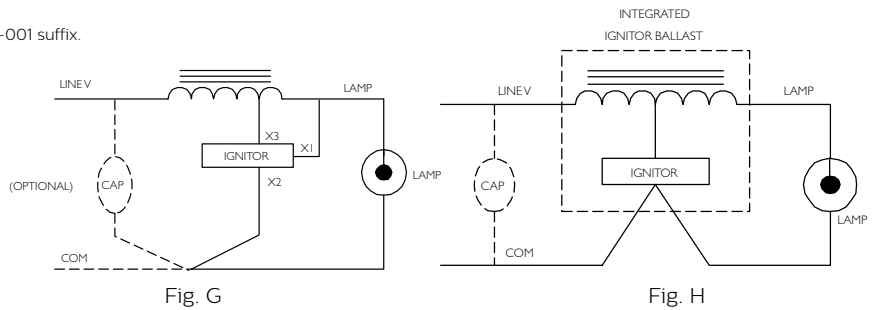

Fig. K

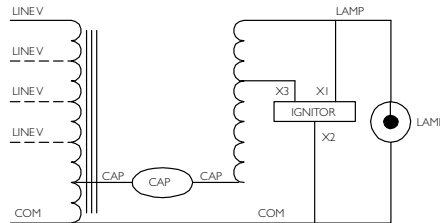

Fig. M

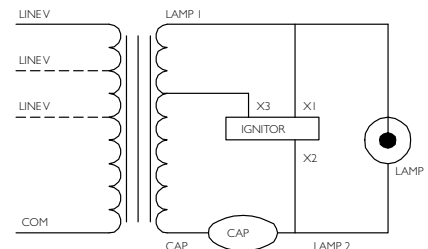

Fig. V

Ballasts-to-Lamp Remote Mounting Distances

Ignitors

Ballasts that include an ignitor to start the HID lamp are limited in the distance which they may be mounted remotely from the lamp because the ignitor pulse attenuates as the wire length between the ballast and lamp increases. All Philips Advance open core & coil ballasts listed in this Atlas include a **standard ignitor** that provides the proper electrical pulse to start lamps when the ballast is mounted **within** the lighting fixture. For most of these ballast/ignitor combinations, the maximum ballast-to-lamp distance is listed as 2 feet. For ballast-to-lamp distances greater than the capability of the standard ignitor, a **long-range ignitor** is required.

Use the tables on the following pages to find the proper long range ignitor for various metal halide and high pressure sodium ballasts. Not all ballasts listed in the Atlas have long-range ignitor options. It may be necessary to use a ballast employing a different circuit to achieve the needed ballast-to-lamp distance.

Whichever ignitor is used, it must be installed with and adjacent to the core & coil, as the two components work together to deliver the proper pulse to the lamp. When remote mounting the ballast away from the lamp, the ignitor must be located next to the ballast and not next to the remote lamp in order to utilize the full ballast to lamp distance range. If the ignitor is located next to the remote lamp, the usable ballast to lamp remote mounting distance will be cut in half.

Metal Halide Ballasts

The distances at which most metal halide ballasts can be located from their respective lamps are limited by the ballast-to-lamp wire size. The exceptions being the ballasts for the new lamps that require an ignitor for starting. The mounting distances for these are limited by the ignitor as shown on the following page.

Use this chart to determine the minimum wire size required for the metal halide (not requiring an ignitor) lamps shown:

Lamp		Maximum One-Way Length of Wire between Lamp and Ballast (ft) (Voltage Drop Limited to 1% of Lamp Voltage)				
Wattage	Metal Halide	#10	#12	#14	#16	#18
175	M57	425	265	165	105	65
250	M58	300	190	120	75	45
1-400 or 2-400	M59	200	125	75	50	30
1000	M47	325	205	125	80	50
1500	M48	225	140	85	55	35