

## HPS Spartan® Industrial Open-Style Control Transformer

### The Economical Solution

The HPS Spartan® line of industrial control transformers are ideally suited for general purpose, industrial and light duty loads. Designed for applications where high inrush or machine tool duty are not necessary, the HPS Spartan industrial open-style control transformer offers an efficient and economical solution. These units are well suited for HVAC applications, signal and alarm systems, motor control circuits, lighting and circuit isolation.

The HPS Spartan control transformer is an open style unit with molded terminal blocks up to 3000 VA or 30 amps. Optional Finger guards and a fuse block adapter kit are available upon request.

For an economical approach to control transformers, the HPS Spartan is the transformer of choice.

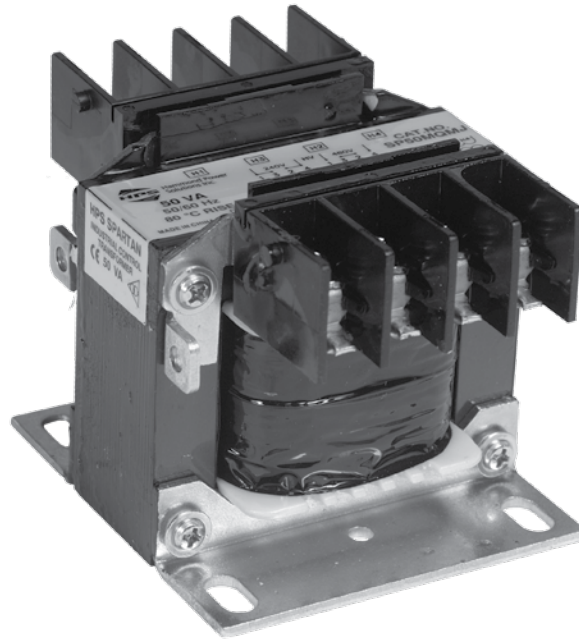

#### STANDARDS

The HPS Spartan Control Transformers meet or exceed the standards established by UL, CSA, IEC and NEMA.

<b>Standard</b>	<b>File #</b>	<b>VA Size</b>
UL (ANSI/UL506)	E50394	All
CSA	LR3902	All
IEC 61558		All
NEMA (ST-1)		All



## Features and Benefits

- Molded terminal blocks for primary and secondary connections<sup>1</sup>
- Coil face termination over 3000VA or 30 amps
- Vacuum Impregnated with Polyester Resin and oven cured
- Bolted core construction
- Bolt-on mounting brackets
- All terminal blocks utilize a combination slot/Phillips #6 screw with a SEMS washer (suitable for 18 AWG to 14 AWG for solid wire and 18 AWG to 12 AWG for stranded wire). Coil face terminations utilize a ¼ - 20 UNC X 0.50" combination slot/Phillips screw and a spring lock washer
- All units supplied with primary and secondary voltage links/jumpers
- 50/60 Hz (60 Hz on SP\*\*\*ACP and SP\*\*\*AR)
- Copper wound coils with high dielectric strength insulation
- Seismically certified in accordance with 2009 IBC for  $S_{DS} \leq 2.00g$ ,  $z/h = 1.0$  and  $I_p = 1.5$
- CSA Certified, UL Listed, CE Marked and RoHS compliant
- Meets NEMA standards
- Superior insulating materials. The HPS Spartan series transformers offer the following insulation systems:
 

Up to 1500 VA:	80°C rise, 130°C temperature class (B)
2000 VA to 5000 VA:	115°C rise, 180°C temperature class (F)
- "Premium Packaging"<sup>1</sup> which feature:
  - Premium fluted cartons
  - Custom molded foam inserts
  - Easy removal and repacking
  - Industry's best box label
- Supplied with trilingual installation and wiring instruction sheets
- 15 year warranty
- Optional finger guards available<sup>1</sup>
- Optional fuse block adapter kit available<sup>1</sup>

<sup>1</sup> up to and including 3000VA or 30 amps

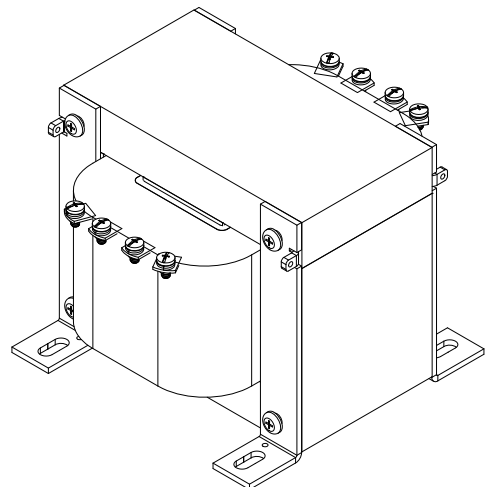
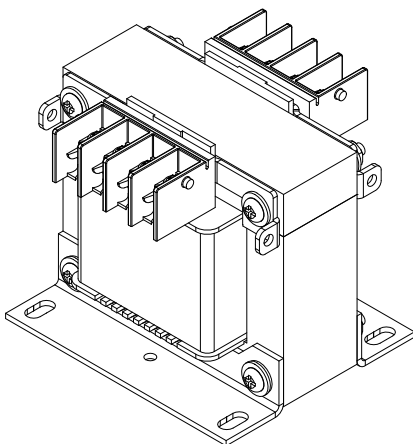

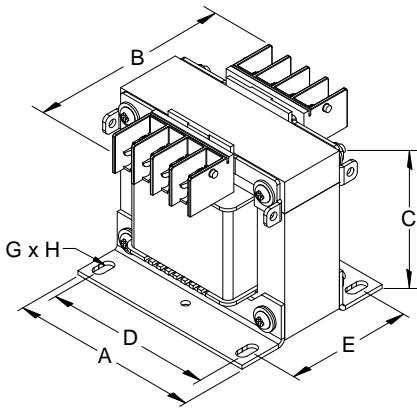

FIGURE A

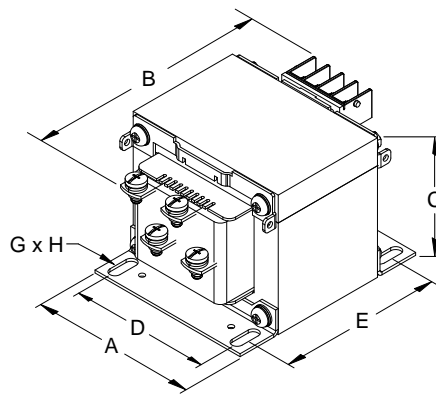

FIGURE B

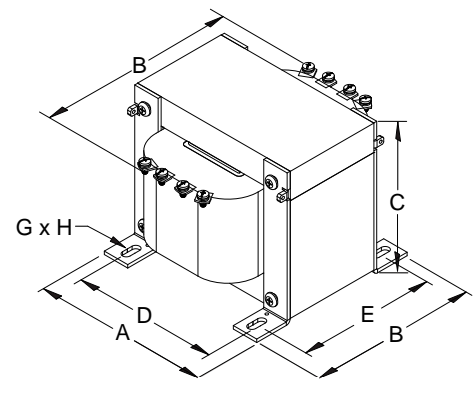

FIGURE C

## Group A

Primary Voltage: 600/480 || 575/460 || 550/440  
 Secondary Voltage: 120 X 240 || 115 X 230 || 110 X 220



VA Rating	CE VA Rating	Catalog Number	Mtg. Fig.	Output Amps	Overall Dimensions			Mounting Centers		Mounting Slot G X H	Height with Finger Guard	Height with Fuse Block Adapter	Approx. Ship Weight Lbs.
					A	B	C	D	E				
50	50	SP50ACP	A	0.42/0.21	2.60	3.82	2.60	2.13	2.64	0.22 x 0.44	2.98	2.79	2.2
100	100	SP100ACP	A	0.83/0.42	2.99	3.74	2.85	2.52	2.60	0.22 x 0.44	3.23	3.04	3.3
150	150	SP150ACP	A	1.25/0.63	2.99	4.29	2.85	2.52	3.15	0.22 x 0.44	3.23	3.04	4.4
250	160	SP250ACP	A	2.08/1.04	3.78	4.09	3.40	3.31	2.99	0.22 x 0.44	3.78	3.59	6.4
350	250	SP350ACP	A	2.92/1.46	3.78	4.49	3.40	3.31	3.39	0.22 x 0.44	3.78	3.59	7.5
500	300	SP500ACP	A	4.17/2.08	4.49	4.69	3.78	3.78	3.66	0.31 x 0.81	4.16	3.97	11
750	500	SP750ACP	A	6.25/3.13	5.25	5.08 <sup>1</sup>	4.37	4.50	4.06	0.31 x 0.81	4.75	4.56	18
1000	650	SP1000ACP	A	8.33/4.17	5.25	5.47 <sup>1</sup>	4.37	4.50	4.45	0.31 x 0.81	4.75	4.56	21
1500	1000	SP1500ACP	A	12.5/6.25	5.25	6.85 <sup>1</sup>	4.37	4.50	5.83	0.31 x 0.81	4.56	4.37	28
2000	1300	SP2000ACP	A	16.7/8.33	6.38	5.87 <sup>1</sup>	5.31	5.75	4.84	0.31 x 0.81	5.69	5.50	34
3000	2000	SP3000ACP	A	25.0/12.5	7.50	7.50	6.50	6.30	6.85	0.44 x 1.00	6.50	6.50	60
5000	3000	SP5000ACP	C	41.7/20.8	8.98	9.88	7.76	7.40	7.13	0.44 x 1.00	N/A	N/A	93

Primary and Secondary voltage links/jumpers supplied standard with all transformers. Refer to page 75 for wiring schematic drawing. All dimensions in inches  
 Custom voltages and VA sizes available upon request.

<sup>1</sup> Note: For 750 through 2000 VA units actual overall depth is 0.24" plus the value in column B.

## Group B

Primary Voltage: 600 || 575 || 550  
 Secondary Voltage: 12 X 24 || 11.5 X 23 || 11 X 22



VA Rating	CE VA Rating	Catalog Number	Mtg. Fig.	Output Amps	Overall Dimensions			Mounting Centers		Mounting Slot G X H	Height with Finger Guard	Height with Fuse Block Adapter	Approx. Ship Weight Lbs.
					A	B	C	D	E				
50	50	SP50AR	A	4.17/2.08	2.60	3.23	2.60	2.13	2.05	0.22 x 0.44	2.98	2.79	1.5
100	100	SP100AR	A	8.33/4.17	2.99	3.74	2.85	2.52	2.60	0.22 x 0.44	3.23	3.04	3.3
150	150	SP150AR	A	12.5/6.25	2.99	4.09	2.85	2.52	2.95	0.22 x 0.44	3.23	3.04	3.9
250	160	SP250AR	A	20.8/10.4	3.78	3.70	3.40	3.31	2.60	0.22 x 0.44	3.78	3.59	5.2
350	250	SP350AR	A	29.2/14.6	3.78	4.29	3.40	3.31	3.19	0.22 x 0.44	3.78	3.59	7.1
500	300	SP500AR	B	41.7/20.8	4.49	5.08	3.78	3.78	3.27	0.31 x 0.81	4.16	3.97	9.9

Primary and Secondary voltage links/jumpers supplied standard with all transformers. All dimensions in inches  
 Refer to page 75 for wiring schematic drawing. Custom voltages and VA sizes available upon request.

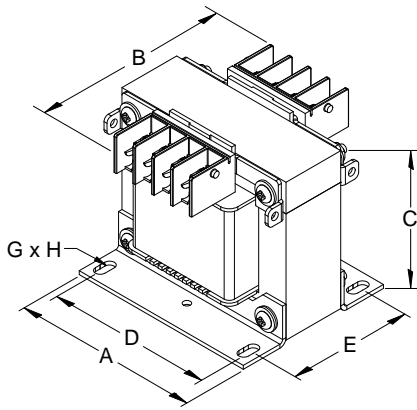

FIGURE A

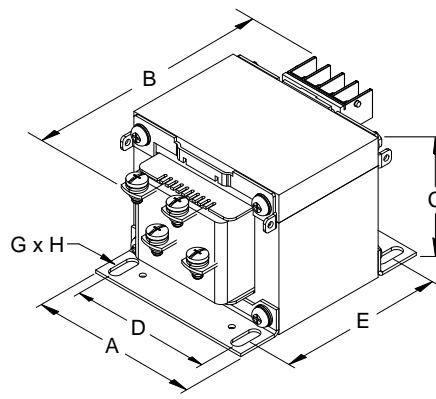

FIGURE B

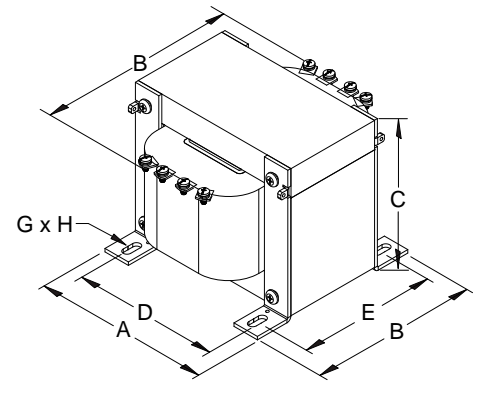

FIGURE C

## Group C

Primary Voltage: 240 X 480 || 230 X 460 || 220 X 440  
 Secondary Voltage: 120 X 240 || 115 X 230 || 110 X 220



 50/60 Hertz

VA Rating	CE VA Rating	Catalog Number	Mtg. Fig.	Output Amps	Overall Dimensions			Mounting Centers		Mounting Slot	Height with Finger Guard	Height with Fuse Block Adapter	Approx. Ship Weight Lbs.
					A	B	C	D	E	G X H			
50	50	SP50MQMJ	A	0.42/0.21	2.60	3.35	2.60	2.13	2.17	0.22 x 0.44	2.98	2.79	1.7
100	100	SP100MQMJ	A	0.83/0.42	2.99	3.74	2.85	2.52	2.60	0.22 x 0.44	3.23	3.04	3
150	150	SP150MQMJ	A	1.25/0.63	2.99	4.29	2.85	2.52	3.15	0.22 x 0.44	3.23	3.04	4.3
250	160	SP250MQMJ	A	2.08/1.04	3.78	4.09	3.40	3.31	2.99	0.22 x 0.44	3.78	3.59	6.5
350	250	SP350MQMJ	A	2.92/1.46	3.78	4.69	3.40	3.31	3.58	0.22 x 0.44	3.78	3.59	8.2
500	300	SP500MQMJ	A	4.17/2.08	4.49	4.69	3.78	3.78	3.66	0.31 x 0.81	4.16	3.97	11
750	500	SP750MQMJ	A	6.25/3.13	5.25	4.69 <sup>1</sup>	4.37	4.50	3.66	0.31 x 0.81	4.75	4.56	16
1000	650	SP1000MQMJ	A	8.33/4.17	5.25	5.47 <sup>1</sup>	4.37	4.50	4.45	0.31 x 0.81	4.75	4.56	21
1500	1000	SP1500MQMJ	A	12.5/6.25	5.25	6.85 <sup>1</sup>	4.37	4.50	5.83	0.31 x 0.81	4.75	4.56	28
2000	1300	SP2000MQMJ	A	16.7/8.33	6.38	5.87 <sup>1</sup>	5.31	5.75	4.84	0.31 x 0.81	5.50	5.31	35
3000	2000	SP3000MQMJ	A	25.0/12.5	7.50	7.50	6.50	6.30	7.28	0.44 x 1.00	6.50	6.50	64
5000	3000	SP5000MQMJ	C	41.7/20.8	8.98	9.88	7.76	7.40	7.28	0.44 x 1.00	N/A	N/A	97

Primary and Secondary voltage links/jumpers supplied standard with all transformers.  
 Refer to page 76 for wiring schematic drawing. Custom voltages and VA sizes available upon request.  
<sup>1</sup> Note: For 750 through 2000 VA units actual overall depth is 0.24" plus the value in column B.

All dimensions in inches

## Group D

Primary Voltage: 240 X 480 || 230 X 460 || 220 X 440  
 Secondary Voltage: 12 X 24 || 11.5 X 23 || 11 X 22



 50/60 Hertz

VA Rating	CE VA Rating	Catalog Number	Mtg. Fig.	Output Amps	Overall Dimensions			Mounting Centers		Mounting Slot	Height with Finger Guard	Height with Fuse Block Adapter	Approx. Ship Weight Lbs.
					A	B	C	D	E	G X H			
50	50	SP50QR	A	4.17/2.08	2.60	3.35	2.60	2.13	2.17	0.22 x 0.44	2.98	2.79	1.7
100	100	SP100QR	A	8.33/4.17	2.99	3.54	2.85	2.52	2.40	0.22 x 0.44	3.23	3.04	3
150	150	SP150QR	A	12.5/6.25	2.99	4.29	2.85	2.52	3.15	0.22 x 0.44	3.23	3.04	4.3
250	160	SP250QR	A	20.8/10.4	3.78	4.09	3.40	3.31	2.99	0.22 x 0.44	3.78	3.59	6.5
350	250	SP350QR	A	29.2/14.6	3.78	4.69	3.40	3.31	3.58	0.22 x 0.44	3.78	3.59	8.3
500	300	SP500QR	B	41.7/20.8	4.49	5.47	3.78	3.78	3.66	0.31 x 0.81	4.16	3.97	11

Primary and Secondary voltage links/jumpers supplied standard with all transformers.  
 Refer to page 76 for wiring schematic drawing. Custom voltages and VA sizes available upon request.

All dimensions in inches



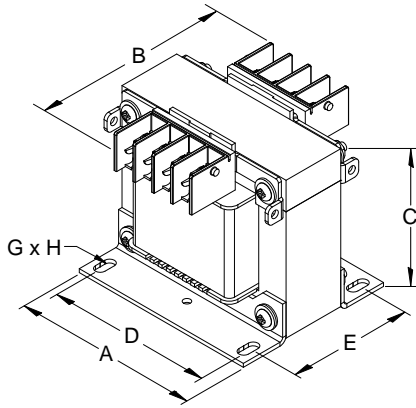

FIGURE A

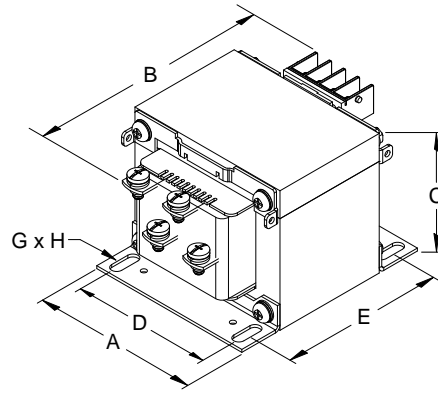

FIGURE B

## Group E

Primary Voltage: **380/347**  
 Secondary Voltage: **120 X 240**



VA Rating	CE VA Rating	Catalog Number	Mtg. Fig.	Output Amps	Overall Dimensions			Mounting Centers		Mounting Slot	Height with Finger Guard	Height with Fuse Block Adapter	Approx. Ship Weight Lbs.
					A	B	C	D	E	G X H			
50	50	SP50KHP	A	0.42/0.21	2.60	3.35	2.60	2.13	2.17	0.22 x 0.44	2.98	2.79	1.7
100	100	SP100KHP	A	0.83/0.42	2.99	3.74	2.85	2.52	2.60	0.22 x 0.44	3.23	3.04	3.4
150	150	SP150KHP	A	1.25/0.63	2.99	4.29	2.85	2.52	3.15	0.22 x 0.44	3.23	3.04	4.4
250	160	SP250KHP	A	2.08/1.04	3.78	4.09	3.40	3.31	2.99	0.22 x 0.44	3.78	3.59	6.7
350	250	SP350KHP	A	2.92/1.46	3.78	4.69	3.40	3.31	3.58	0.22 x 0.44	3.78	3.59	8.4
500	300	SP500KHP	A	4.17/2.08	4.49	4.69	3.78	3.78	3.66	0.31 x 0.81	4.16	3.97	12
750	500	SP750KHP	A	6.25/3.13	5.25	4.69 <sup>1</sup>	4.37	4.50	3.66	0.31 x 0.81	4.75	4.56	17
1000	650	SP1000KHP	A	8.33/4.17	5.25	5.47 <sup>1</sup>	4.37	4.50	4.45	0.31 x 0.81	4.75	4.56	21
1500	1000	SP1500KHP	A	12.5/6.25	6.38	4.88 <sup>1</sup>	5.31	5.75	3.86	0.31 x 0.81	5.50	5.31	29

Primary and Secondary voltage links/jumpers supplied standard with all transformers.  
 Refer to page 77 for wiring schematic drawing. Custom voltages and VA sizes available upon request.  
<sup>1</sup> Note: For 750 through 1500 VA units actual overall depth is 0.24" plus the value in column B.

All dimensions in inches

## Group F

Primary Voltage: **380/347**  
 Secondary Voltage: **12 X 24**



VA Rating	CE VA Rating	Catalog Number	Mtg. Fig.	Output Amps	Overall Dimensions			Mounting Centers		Mounting Slot	Height with Finger Guard	Height with Fuse Block Adapter	Approx. Ship Weight Lbs.
					A	B	C	D	E	G X H			
50	50	SP50KHR	A	4.17/2.08	2.60	3.35	2.60	2.13	2.17	0.22 x 0.44	2.98	2.79	1.7
100	100	SP100KHR	A	8.33/4.17	2.99	3.74	2.85	2.52	2.60	0.22 x 0.44	3.23	3.04	3.3
150	150	SP150KHR	A	12.5/6.25	2.99	4.29	2.85	2.52	3.15	0.22 x 0.44	3.23	3.04	4.4
250	160	SP250KHR	A	20.8/10.4	3.78	4.09	3.40	3.31	2.99	0.22 x 0.44	3.78	3.59	6.4
350	250	SP350KHR	A	29.2/14.6	3.78	4.69	3.40	3.31	3.58	0.22 x 0.44	3.78	3.59	8.1
500	300	SP500KHR	B	41.7/20.8	4.49	5.47	3.78	3.78	3.66	0.31 x 0.81	4.16	3.97	11

Primary and Secondary voltage links/jumpers supplied standard with all transformers.  
 Refer to page 77 for wiring schematic drawing. Custom voltages and VA sizes available upon request.

All dimensions in inches





FIGURE A



FIGURE B

## Group G

Primary Voltage: 277

Secondary Voltage: 120



50/60 Hertz

VA Rating	CE VA Rating	Catalog Number	Mtg. Fig.	Output Amps	Overall Dimensions			Mounting Centers		Mounting Slot	Height with Finger Guard	Height with Fuse Block Adapter	Approx. Ship Weight Lbs.
					A	B	C	D	E	G X H			
50	50	SP50NJ	A	0.42	2.60	3.35	2.60	2.13	2.17	0.22 x 0.44	2.98	2.79	1.6
100	100	SP100NJ	A	0.83	2.99	3.54	2.85	2.52	2.40	0.22 x 0.44	3.23	3.04	3.2
150	150	SP150NJ	A	1.25	2.99	4.29	2.85	2.52	3.15	0.22 x 0.44	3.23	3.04	4.3
250	160	SP250NJ	A	2.08	3.78	4.09	3.40	3.31	2.99	0.22 x 0.44	3.78	3.59	6.4
350	250	SP350NJ	A	2.92	3.78	4.69	3.40	3.31	3.58	0.22 x 0.44	3.78	3.59	8.1
500	300	SP500NJ	A	4.17	4.49	4.69	3.78	3.78	3.66	0.31 x 0.81	4.16	3.97	11
750	500	SP750NJ	A	6.25	5.25	5.08 <sup>1</sup>	4.37	4.50	4.06	0.31 x 0.81	4.75	4.56	18
1000	650	SP1000NJ	A	8.33	5.25	5.47 <sup>1</sup>	4.37	4.50	4.45	0.31 x 0.81	4.75	4.56	20
1500	1000	SP1500NJ	A	12.50	5.25	6.85 <sup>1</sup>	4.37	4.50	5.83	0.31 x 0.81	4.75	4.56	29

Primary and Secondary voltage links/jumpers supplied standard with all transformers.  
 Refer to page 78 for wiring schematic drawing. Custom voltages and VA sizes available upon request.  
<sup>1</sup> Note: For 750 through 1500 VA units actual overall depth is 0.24" plus the value in column B.

All dimensions in inches

## Group H

Primary Voltage: 120 X 240 || 115 X 230 || 110 X 220

Secondary Voltage: 12 X 24 || 11.5 X 23 || 11 X 22



50/60 Hertz

VA Rating	CE VA Rating	Catalog Number	Mtg. Fig.	Output Amps	Overall Dimensions			Mounting Centers		Mounting Slot	Height with Finger Guard	Height with Fuse Block Adapter	Approx. Ship Weight Lbs.
					A	B	C	D	E	G X H			
50	50	SP50PR	A	4.17/2.08	2.60	3.35	2.60	2.13	2.17	0.22 x 0.44	2.98	2.79	1.7
100	100	SP100PR	A	8.33/4.17	2.99	3.74	2.85	2.52	2.60	0.22 x 0.44	3.23	3.04	3
150	150	SP150PR	A	12.5/6.25	2.99	4.29	2.85	2.52	3.15	0.22 x 0.44	3.23	3.04	4.3
250	160	SP250PR	A	20.8/10.4	3.78	3.90	3.40	3.31	2.80	0.22 x 0.44	3.78	3.59	5.9
350	250	SP350PR	A	29.2/14.6	3.78	4.69	3.40	3.31	3.58	0.22 x 0.44	3.78	3.59	8.2
500	300	SP500PR	B	41.7/20.8	4.49	5.47	3.78	3.78	3.66	0.31 x 0.81	4.16	3.97	11

Primary and Secondary voltage links/jumpers supplied standard with all transformers.  
 Refer to page 78 for wiring schematic drawing. Custom voltages and VA sizes available upon request.

All dimensions in inches



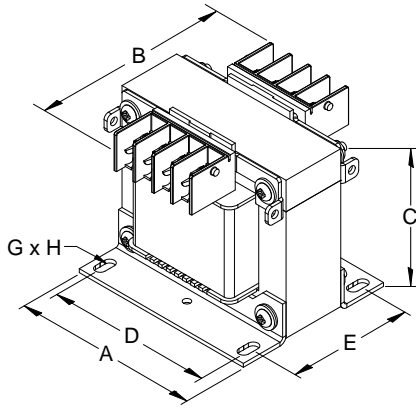

FIGURE A

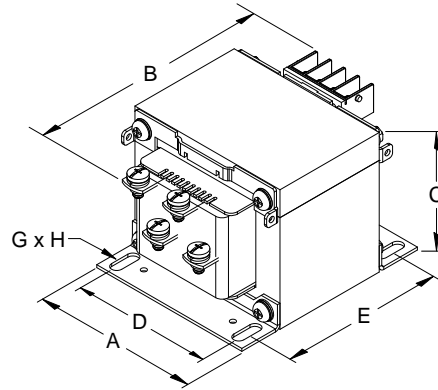

FIGURE B

## Group I

Primary Voltage: 208 X 416 || 200 X 400 || 190 X 380  
 Secondary Voltage: 120 X 240 || 115 X 230 || 110 X 220



50/60 Hertz

VA Rating	CE VA Rating	Catalog Number	Mtg. Fig.	Output Amps	Overall Dimensions			Mounting Centers		Mounting Slot	Height with Finger Guard	Height with Fuse Block Adapter	Approx. Ship Weight Lbs.
					A	B	C	D	E	G X H			
50	50	SP50SP	A	0.42/0.21	2.60	3.35	2.60	2.13	2.17	0.22 x 0.44	1.6	2.60	1.6
100	100	SP100SP	A	0.83/0.42	2.99	3.54	2.85	2.52	2.40	0.22 x 0.44	3	2.85	3
150	150	SP150SP	A	1.25/0.63	2.99	4.29	2.85	2.52	3.15	0.22 x 0.44	4.3	2.85	4.3
250	160	SP250SP	A	2.08/1.04	3.78	4.09	3.40	3.31	2.99	0.22 x 0.44	6.5	3.40	6.5
350	250	SP350SP	A	2.92/1.46	3.78	4.69	3.40	3.31	3.58	0.22 x 0.44	8.3	3.40	8.3
500	300	SP500SP	A	4.17/2.08	4.49	4.69	3.78	3.78	3.66	0.31 x 0.81	11	3.78	11
750	500	SP750SP	A	6.25/3.13	5.25	4.69 <sup>1</sup>	4.37	4.50	3.66	0.31 x 0.81	16	4.75	16
1000	650	SP1000SP	A	8.33/4.17	5.25	5.47 <sup>1</sup>	4.37	4.50	4.45	0.31 x 0.81	20	4.75	20
1500	1000	SP1500SP	A	12.5/6.25	6.38	4.88 <sup>1</sup>	5.31	5.75	3.86	0.31 x 0.81	27	5.69	27

Primary and Secondary voltage links/jumpers supplied standard with all transformers.  
 Refer to page 79 for wiring schematic drawing. Custom voltages and VA sizes available upon request.

All dimensions in inches

<sup>1</sup> Note: For 750 through 1500 VA units actual overall depth is 0.24" plus the value in column B.

## Group J

Primary Voltage: 208 X 416 || 200 X 400 || 190 X 380  
 Secondary Voltage: 12 X 24 || 11.5 X 23 || 11 X 22



50/60 Hertz

VA Rating	CE VA Rating	Catalog Number	Mtg. Fig.	Output Amps	Overall Dimensions			Mounting Centers		Mounting Slot	Height with Finger Guard	Height with Fuse Block Adapter	Approx. Ship Weight Lbs.
					A	B	C	D	E	G X H			
50	50	SP50SR	A	4.17/2.08	2.60	3.35	2.60	2.13	2.17	0.22 x 0.44	2.98	2.79	1.6
100	100	SP100SR	A	8.33/4.17	2.99	3.54	2.85	2.52	2.40	0.22 x 0.44	3.23	3.04	3.1
150	150	SP150SR	A	12.5/6.25	2.99	4.29	2.85	2.52	3.15	0.22 x 0.44	3.23	3.04	4.3
250	160	SP250SR	A	20.8/10.4	3.78	4.09	3.40	3.31	2.99	0.22 x 0.44	3.78	3.59	6.5
350	250	SP350SR	A	29.2/14.6	3.78	4.69	3.40	3.31	3.58	0.22 x 0.44	3.78	3.59	8.3
500	300	SP500SR	B	41.7/20.8	4.49	5.47	3.78	3.78	3.66	0.31 x 0.81	4.16	3.97	11

Primary and Secondary voltage links/jumpers supplied standard with all transformers.  
 Refer to page 79 for wiring schematic drawing. Custom voltages and VA sizes available upon request.

All dimensions in inches



## Optional Accessories

### Finger Guards

HPS Spartan industrial control transformers up to and including 3000VA or 30 amps are available with optional finger guards.

Part Number	Applicable Transformer Part Number Suffixes	Applicable VA Sizes
SPFG1	AR, QR, PR, KHR, SR	50 to 500
SPFG1	KHP, SP, NJ	50 to 1500
SPFG1	ACP, MQMJ	50 to 3000

Note: Each finger guard supplies either the primary or secondary side. Finger guard option not available on SP5000ACP and SP5000MQMJ standard units. Add 0.38" per finger guard to overall depth (column B) on units from 50 VA to 500 VA and 0.31" to units from 750 VA to 2000 VA when finger guard has been installed. For custom units, optional finger guards are only available on units up to 3000VA or 30 amps.

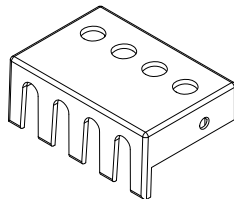

**Finger Guard**  
(Optional)

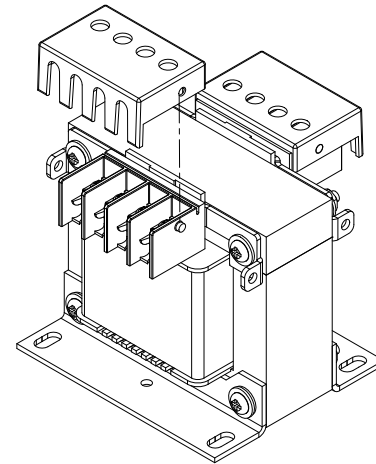

**Sample Assembly Drawing for Optional Finger Guard Installation**  
(Only available for units supplied with either a primary or secondary molded terminal block)

### Fuse Block Adapter Kit

HPS Spartan industrial control transformers up to and including 3000VA or 30 amps are available with optional fuse block adapter kits. The Fuse Block Adapter Kit is designed to allow for the installation of any third party after market fuse block assembly onto the industrial control transformer. The transformer must be a unit that incorporates a molded terminal block on either the primary or secondary side.

Note: HPS does not provide any jumpers or appropriate fuses for any after market fuse block you install on the HPS Spartan industrial control transformer. The HPS fuse block adapter kit provides only the mechanical means of attaching a third party after market fuse block. HPS does not recommend any specific fuse block or fuse supplier. For a recommended size of fuse, please see page # 32.

Kit Part Number	Applicable Transformer Part Number Suffixes	Applicable VA Sizes
SPFBAK1	AR, QR, PR, KHR, SR	50 to 500
SPFBAK1	KHP, SP, NJ	50 to 1500
SPFBAK1	ACP, MQMJ	50 to 3000

Note: Only 1 fuse block adapter kit is required per transformer. Fuse block adapter kit not available on SP5000ACP and SP5000MQMJ standard units. Add 0.38" per fuse block adapter to overall depth (column B) on units from 750 VA to 3000 VA when optional fuse block adapter is installed. For custom units, optional fuse block adapter kit is only available on units up to 3000VA or 30 amps.

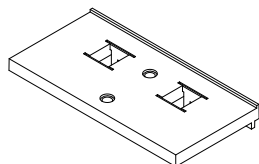

**Fuse Block Adapter Kit**  
(Optional)

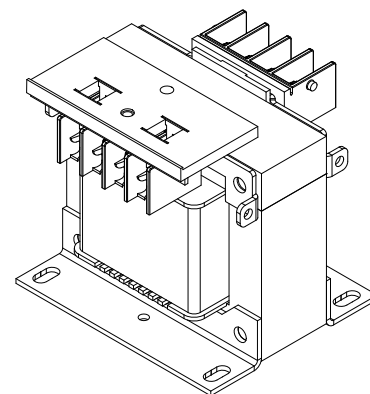

**Sample Assembly Drawing for Optional Fuse Block Adapter Installation**

For detailed installation instructions of HPS Spartan transformers or the optional finger guards and fuse block adapter kits, please visit our website under Products and Services - Literature & Resources - Instruction Sheets - Control Transformers. Or go to the following link: [http://www.hammondpowersolutions.com/products/product\\_literature/instruction\\_sheets/control\\_transformers.php](http://www.hammondpowersolutions.com/products/product_literature/instruction_sheets/control_transformers.php)