



# T and B Series

# EEMAC / NEMA 1 Splitter Troughs and Boxes

### TECHNICAL READOUT

Catalog No.		Grounding Kit (Optional)	Amps	Dimensions			Weight lbs.
Splitter Troughs	3 wires			4 wires	A	B	
T273	T274	TGR200	70	24	6	4	12
T373	T374	TGR200	70	36	6	4	17
T473	T474	TGR200	70	48	6	4	21
T2103	T2104	TGR200	125	24	6	4	12
T3103	T3104	TGR200	125	36	6	4	17
T4103	T4104	TGR200	125	48	6	4	21
T6103	T6104	TGR200	125	72	8	5	39
T2203		TGR200	225	24	8	5	16
T3203	T3204	TGR200	225	36	8	5	22
T4203	T4204	TGR200	225	48	8	5	27
T5203	T5204	TGR200	225	60	8	5	33
T6203	T6204	TGR200	225	72	8	5	39
T3403		TGR400	400	36	10	6	35
T4403	T4404	TGR400	400	48	10	6	45
T5403	T5404	TGR400	400	60	10	6	58
T6403	T6404	TGR400	400	72	10	6	62
T4603	T4604	TGR600	600	48	10	6	45
T5603	T5604	TGR600	600	60	10	6	58
T6603	T6604	TGR600	600	72	10	6	62

### Splitter Boxes

B73	B74	BGR200	70	12	10	4	9
B103	B104	BGR200	125	12	10	4	9
B203	B204	BGR200	225	18	12	5	16
B403	B404	BGR400	400	24	17	6	37
B603	B604	BGR600	600	30	24	7	63

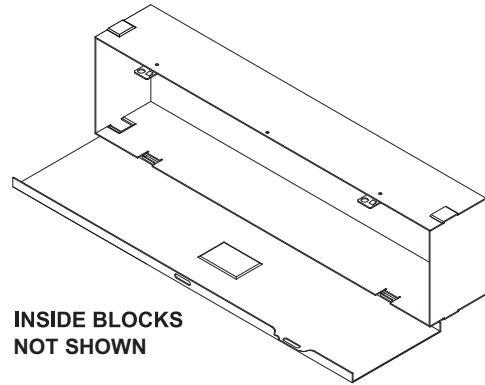

INSIDE BLOCKS  
NOT SHOWN

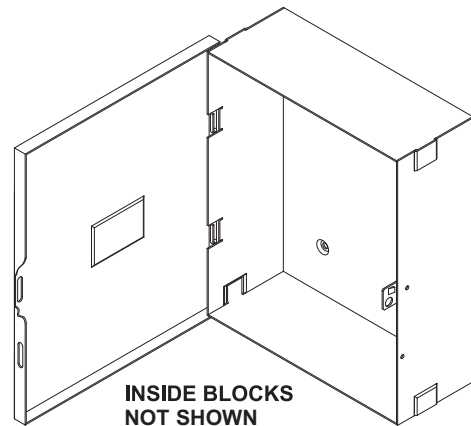

INSIDE BLOCKS  
NOT SHOWN

### Application:

Type 1 enclosure designed for indoor distribution (600V maximum, Cu-Al).

### Construction:

- 16 gauge steel
- Factory installed splitter blocks
- Retractable sealing hasp
- ANSI/ASA61 grey polyester - epoxy textured powder coating inside out

### Also Available:

- Grounding kit
- Aluminium, SS, galvanized steel
- Special finishes & sizes

### Standards:

- CSA certified 150359





# T and B Series

# EEMAC / NEMA 1 Splitter Troughs, Boxes

## T Series

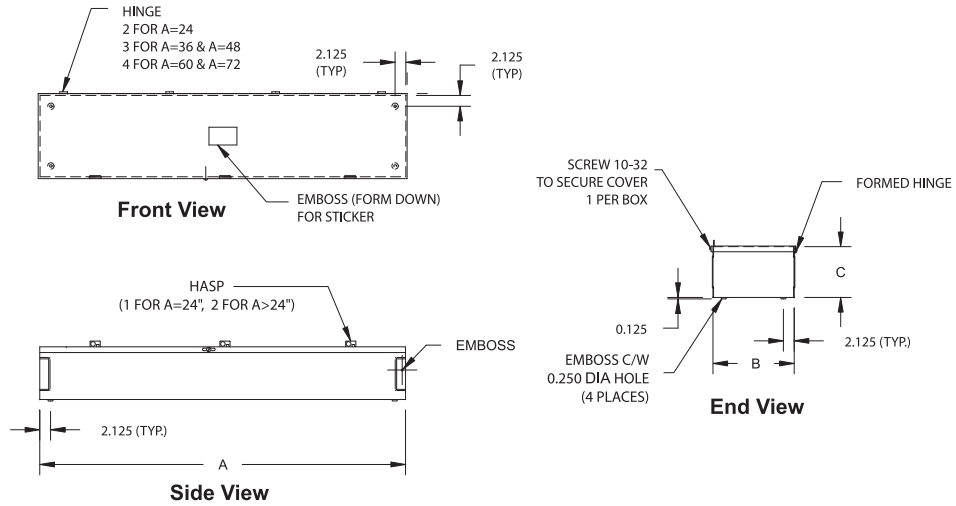

## B Series

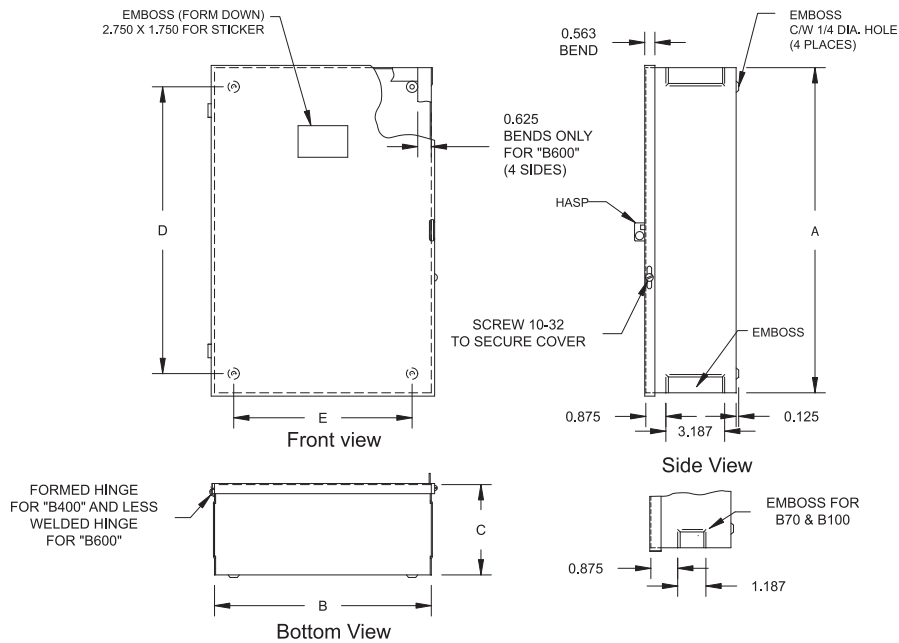

### TECHNICAL READOUT

Catalog No.	D	E
B70	7.750	5.750
B100	7.750	5.570
B200	13.750	7.750
B400	19.750	12.750
B600	28.000	22.500