



A

Overview

The AdaptaBeacon line of flashing or steady lights is designed to give a visual indication or provide a supplementary audible warning sound depending on the model selected. The cast zinc base may also double for use as a junction box. 120 and 240VAC beacons are CSA certified.

B

Shatter resistant Lexan® lenses and domes. Stainless steel clamp rings. Easy lamp replacement with bayonet base type bulbs. Special optics in the impact resistant Lexan lenses ensure light is efficiently dispersed. Available in six colors: red, amber, blue, green, magenta or clear.

C

Applications

These lights are particularly effective in high noise level areas, especially where ear protection must be worn and audible signals may not be heard or misunderstood. They can advise personnel in manufacturing and process areas when an operation is starting or stopping. They can signal malfunctions in equipment, such as assembly line jams, or blocked ventilator. They can warn personnel that they are entering a restricted area or an area of high danger.

D

Installation

For indoor installation it can be mounted in any direction. For weatherproof and outdoor installation lens must face directly up. A standard base design allows installation directly to surface or to a 4" octagon box or on a 1/2" NPT conduit.

E

F

G

Standard Features

- **CSA Certified (120 and 240VAC models only)**
- **Weatherproof -35°C to +66°C (-31°F to 150°F)**
- **Three styles to choose from:**
 - Flashing or Steady Light
 - Flashing Light with Horn
 - Flashing Light with Protective Dome Cover
- **Direct or pipe mounting or mounting on a 4" octagon box**

50CSIN Steady Beacon Light

Direct or Pipe Mount - 120VAC

When activated, provides a continuous on visual alarm indication.

49C Flashing Beacon Light

with Protective Dome Cover - Direct or Pipe Mount - 120 or 240VAC

Flashing light with protective acrylic dome cover provides easy cleaning in dusty or sooty environments.

50C Flashing Beacon Light

Direct or Pipe Mount - 24/120/240VAC

Same features as the 49C less protective Dome.

51C Flashing Beacon Light

with Warning Horn - Direct or Pipe Mount 12Vdc, 24Vdc, 24VAC, 120VAC

Combines low cost, flashing light with self contained base mounted flashing warning horn, rated at 85dB at 10 feet. Ideally suited for signalling the stoppage of equipment, or pinpointing a problem location.

50C Series Flashing Light and 50CSIN Series Steady Light



51C Series Flashing Light with Horn

49C Series Flashing Light with Protective Dome Cover



continues...

AdaptaBeacon® Steady On and Flashing Lights

49C, 50C, and 51C Series





...continued

Ordering Information

Description	Cat. No.	Repl. Lens	Cat. No. Dome Cover	Nom. Amp Rating	Repl. Flasher	Voltage	Mounting
Steady Light	50CSIN(+)-N5-40WH	92L(+)	--	.28	--	120VAC*	1. Direct surface (indoor installation only) 2. Mounting on a 4" octagon box (indoor installation only) 3. Mounting on 1/2" conduit (indoor or outdoor installation)
Flashing Light with Protective Dust Cover Flash Rate =60 FPM	49C(+)-R5	92L(+)	52LC	.10	46095-0031	240VAC*	
	49C(+)-N5-40WH	92L(+)	52LC	.26	46095-0021	120VAC*	
Flashing Light Flash Rate =60 FPM	50C(+)-R5	92L(+)	--	.10	46095-0031	240VAC*	
	50C(+)-N5-40WH	92L(+)	--	.26	46095-0021	120VAC*	
	50C(+)-G5-20WH	92L(+)	--	.90	46095-0030	24VAC*	
Flashing Light with Warning Horn Flash Rate =60 FPM	51C(+)-N5-40W	92L(+)	--	.29	46095-0021	120VAC*	
	51C(+)-G5-20W	92L(+)	--	1.1	46095-0030	24VAC*	
	51C(+)-G1	92L(+)	--	1.1	46095-0030	24Vdc	
	51C(+)-E1	92L(+)	--	1.0	46095-0030	12Vdc	

(+) Specify color: R=Red, A=Amber, B=Blue, G=Green, C=Clear, M=Magenta
 * 50/60 Hz

Installation and Mounting

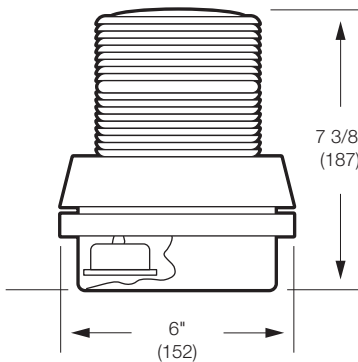

51C Series
 Flashing light w/warning horn direct or pipe mount

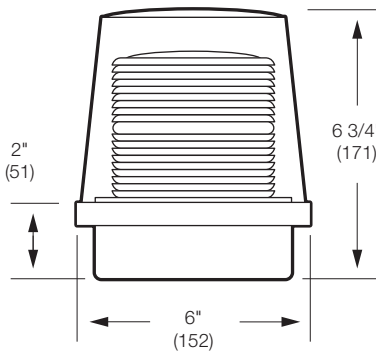

49C Series
 Flashing light w/protective dome

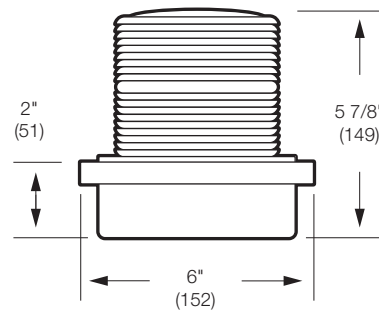

50C Series
 Flashing or steady light direct or pipe mount

A

B

C

D

E

F

G