

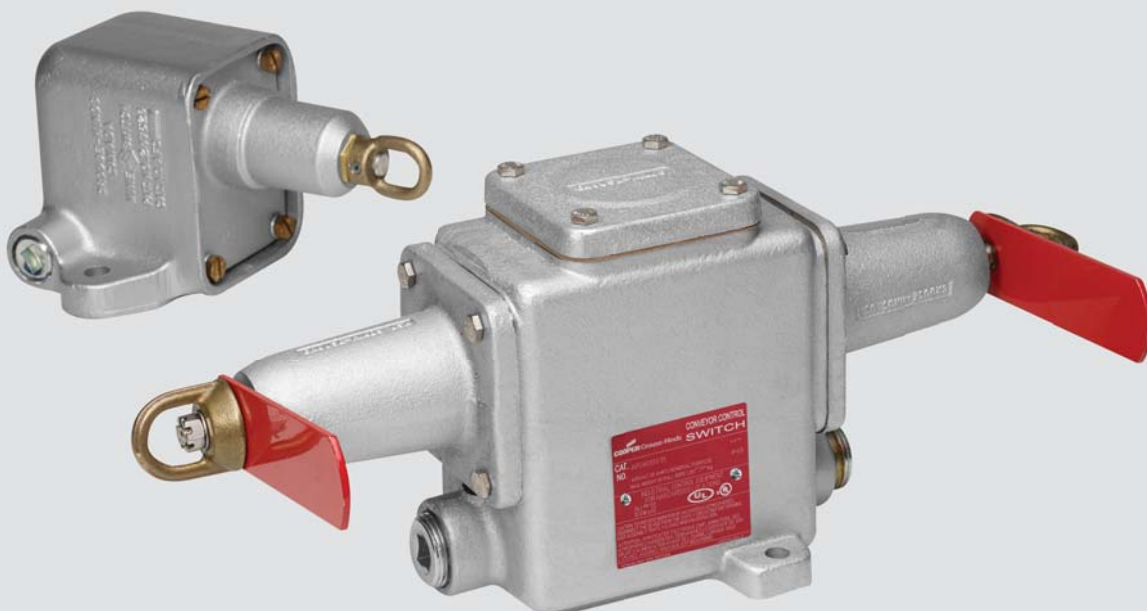

Control & Signal Switches

For Mining Applications

**COOPER**



Control & Signal Solutions:

Signal Switch Quick Selector Chart

| Feature | Series | | | | |
|--------------------------|--------|-----|-----|-----|-----|
| | AFU | AFC | AFK | AFS | AFM |
| Remote Signaling | ● | ● | ● | ● | ● |
| Audible Signaling | × | × | ● | × | ● |
| Visible Signaling | × | × | ● | × | × |
| Magnetic Motor Control | ● | × | × | × | × |
| Heavy-duty 600 VAC Max | ● | × | × | × | × |
| Heavy-duty 125 VAC Max | × | ● | ● | ● | ● |
| Water Shedding Cover | × | × | ● | ● | ● |
| Water Shedding Enclosure | ● | ● | × | × | × |

● Feature available × Feature not available



Alignment, Control & Signal Solutions

Crouse-Hinds belt alignment, control and signal devices for mining are designed to be a safe, rugged, worry-free answer to your productivity needs. Durable materials, innovative design and a focus on safety let you concentrate on other parts of your plant while your conveyor system stays running.

- **Visual & Directional Indicators**
Quick and easy identification to get you safely running again
- **Multiple Material Options**
Tough, durable enclosures designed to stand up to your needs
- **Multiple Conduit Entry Points**
Provide flexibility in retro-fit or new build applications

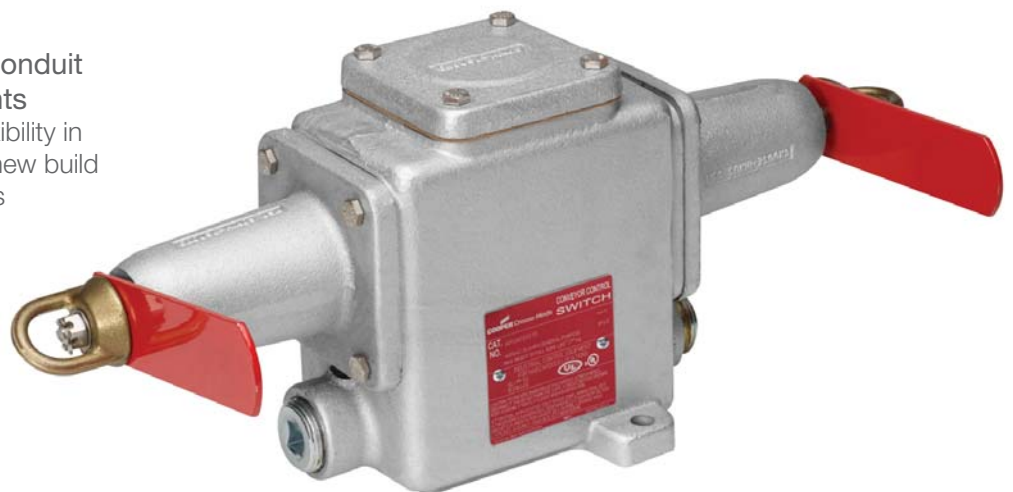

Belt Control Switch Application

Single-end units are used at the ends of the conveyor system and spaced maximum 30 meters (100 ft) between switches. Double-end units are used along the conveyor and spaced maximum 30 meters (100 ft) from each side of unit. Double-end units contain two red painted indicator arms on each side for actuating indication.

Engineered to perform in the harshest environments



Conveyor Belt Alignment Switch Application

15Amp, 600VAC switch with two normally open and two normally closed contact arrangements. The operating arm actuates the normally closed contacts within a 7° to 15° travel of the arm (for signaling) and actuates the normally open contacts (for shut-off) within 23° to 31° of the arm's vertical position.

Over-travel protection of 85° prevents severe run-off damage to switch mechanism. The spring loaded operating arm returns the switch to normal position when belt interference is removed.

Conveyor belt alignment switches are installed on both sides of conveyor system and spaced maximum 90 meters (300ft) from each side of unit.

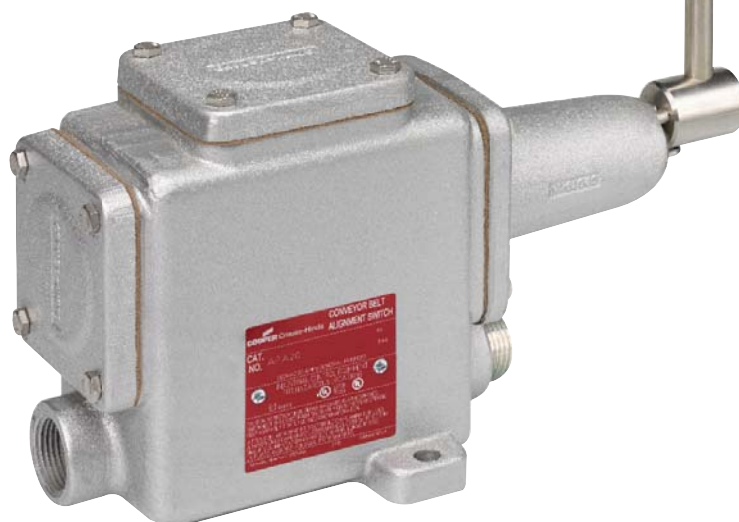

AFU & AFUX Conveyor Belt Control Switch

APPLICATIONS:

AFU and AFUX conveyor control switches are used:

- As emergency or normal "STOP" switch for conveyor lines, cranes, unloaders, bulk handling systems and similar equipment
- In steel mills, mining and ore and coal handling operations, automotive and other assembly lines, warehouses, loading docks and various process industry facilities
- In the control circuit of magnetic motor starters to shut down motor-driven conveyors or other machinery when switch is actuated

AFU series complies with requirements for use in Class II areas having combustible dusts that may or may not be electrically conductive.

AFU series are also gasketed for use in hosedown areas even when combustible dusts are present.

AFUX series complies with requirements for use in NEC Class I areas which are hazardous due to the presence of flammable vapors or gases. AFUX series also complies with requirements for use in NEC Class I areas which are hazardous due to the presence of flammable vapors or gases. AFUX series also complies with NEC requirements for use in Class II hazardous areas, or for use in NEC hazardous areas classified simultaneously as Class I and Class II.

FEATURES:

- Furnished with one or two end units, each containing 2-NO and 2-NC contact arrangements.
- Precision switches provide maintained contact (switches have a snap action mechanism).
- Enclosure has three 1" conduit hubs – two for horizontal through feed and one at the bottom. Cast mounting lugs on 1-1/2" centers permit attachment to the web of a standard 3" angle iron.
- In installation, the actuating line or cable is connected from a fixed point to the loop on the end unit. A pull on the line of the required operating force and with a total movement of 1/2" actuates the plunger, opens the switch and trips the red painted indicating arm forward, which locks the plunger in the actuated (switch open) position. Returning the indicating arm to its normal position resets the mechanism. A typical installation would include single end switch units at each end of the conveyor with double end switch units between.
- Depending on the size and length of line, supports at properly spaced intervals may be necessary to ensure that the line or cable weight alone will not actuate switch.

CERTIFICATIONS AND COMPLIANCES:

AFU Series

- NEC/CEC:
 - Class II, Division 1, Groups E, F, G
 - Class II, Division 2, Groups F, G
 - Class III
- Encl. 3, 5
- NEMA: 3, 4, 9EFG
- IP66
- UL Standard: 698
- CSA Standard: 22.2 No. 30

AFUX Series

- NEC:
 - Class I, Division 1 & 2, Groups C, D
 - Class II, Division 1, Groups E, F, G
 - Class II, Division 2, Groups F, G
 - Class III
- NEMA: 3, 7CD, 9EFG
- IP65
- UL Standard: 698
- cUL

STANDARD MATERIALS:

- Enclosure – Feraloy® iron alloy
- Plunger – stainless steel
- Loop – bronze
- Indicating arm – steel

ORDERING INFORMATION:

| Description | Maximum Weight of Unsupported Line or Cable Without Actuating Switch† (lbs) | Total Operating Force Required (lbs) | Contact Arrangements With 2-NO, 2-NC in Each End Unit | |
|------------------|---|--------------------------------------|---|-------------|
| | | | Cat# | Cat# |
| Single end left | 15 | 25 | AFU0333 50 | AFUX0333 50 |
| Single end left | 25 | 50 | AFU0333 60 | AFUX0333 60 |
| Single end right | 15 | 25 | AFU0333 05 | AFUX0333 05 |
| Single end right | 25 | 50 | AFU0333 06 | AFUX0333 06 |
| Double end | 15 | 25 | AFU0333 55 | AFUX0333 55 |
| Double end | 25 | 50 | AFU0333 66 | AFUX0333 66 |

† A galvanized steel aircraft cable, supported every 10' is recommended

DIMENSIONS (IN INCHES*):

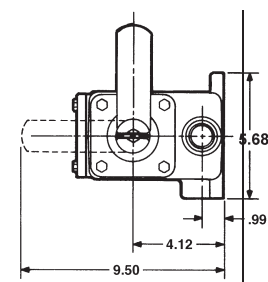
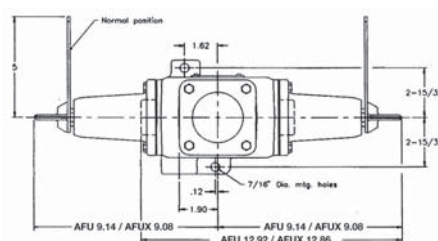

*Dimensions are approximate, not for construction purposes.

STANDARD FINISHES:

- Feraloy iron alloy – electrogalvanized and aluminum acrylic paint
- Steel – electrogalvanized with chromate finish (red acrylic paint on indicating arm)
- Bronze – natural

ELECTRICAL RATING:

- Control circuit switch – 15 AMP, 600 VAC max.

OPTIONS:

| Description | Suffix |
|---|--------|
| Finish: Corro-free™ epoxy powder coat – for coating outside only. | S752 |

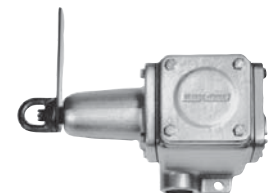

AFU0333-50 Single end left

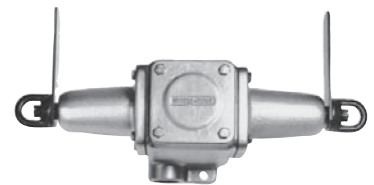

AFU0333-66 Double end

AFA & AFAX Conveyor Belt Alignment Switch

APPLICATIONS:

AFA, AFAX conveyor belt alignment switches are used:

- As emergency or normal “STOP” switch for conveyor belts whenever they become misaligned or run off their tracks due to excessive speed, uneven load, leveling, breakage and/or other problems.
- In steel mills, mining and ore and coal handling operations, automotive and other assembly lines, warehouses, loading docks, grain loading and handling facilities, and various other bulk handling operations.
- In the control circuit of magnetic motor starters to shut down motor-driven conveyors in case of abnormal belt misalignment or run-off.

AFA series complies with requirements for use in Class II areas having combustible dusts that may or may not be electrically conductive.

AFA series are also gasketed for use in hose-down areas even when combustible dusts are present.

AFAX series complies with requirements for use in NEC Class I areas which are hazardous due to the presence of flammable vapors or gases. AFAX series also complies with NEC requirements for use in Class II hazardous areas, or for use in NEC hazardous areas classified simultaneously as Class I and Class II.

FEATURES:

- Furnished with precision switches that provide normally open and normally closed contacts (switches have a snap action mechanism).
- Housing consists of a center section which can be mounted either vertically or horizontally, and a switch housing with an attached switch operating arm.
- Enclosure has three 1” conduit hubs. Cast mounting lugs on 1-1/2” center permit attachment to the web of a standard 3” angle iron.
- Operating arm has 3-1/2” long stainless steel protective roller. Approximately 3/4” lateral movement of operating arm actuates switch.
- Spring loaded operating arm will automatically return switch to normal position when belt interference is removed.
- A severe conveyor belt run-off can rotate the operating arm counter-clockwise up to 85 degrees without damage to the switch mechanism.
- Installation of AFA or AFAX unit on either side of a conveyor belt allows approximately 1” or a predetermined allowable belt misalignment before switch is actuated. A typical installation would include a pair of AFA or AFAX units at each end of the conveyor belt where belt returns.

CERTIFICATIONS AND COMPLIANCES:

AFA Series

- NEC/CEC:
Class II, Division 1, Groups E, F, G
Class II, Division 2, Groups F, G
Class III
- NEMA: 3, 4, 9EFG
- IP66
- UL Standard: 698
- CSA Standard: 22.2 No. 25

AFAX Series

- NEC:
Class I, Division 1 & 2, Groups C, D
Class II, Division 1, Groups E, F, G
Class II, Division 2, Groups F, G
Class III
- NEMA: 3, 7CD, 9EFG
- IP65
- UL Standard: 1203
- CSA Standard: 22.2 No. 30

STANDARD MATERIALS:

- Enclosure – Feraloy® iron alloy
- Bearing and operating arm – stainless steel with plastic end caps

TYPICAL AFA SWITCH APPLICATION:

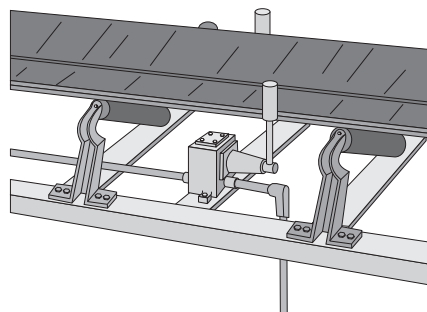

DIMENSIONS (IN INCHES*):

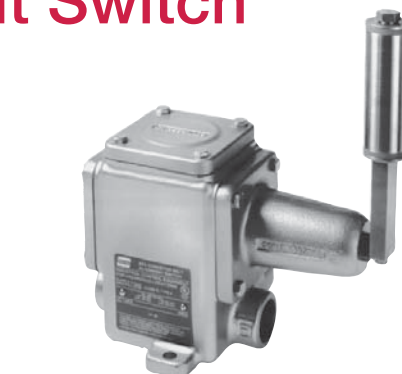
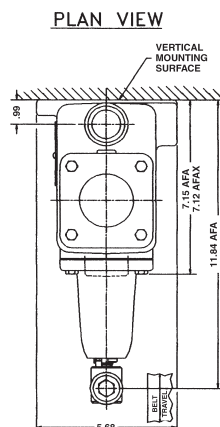

STANDARD FINISHES:

- Feraloy iron alloy – electrogalvanized and aluminum acrylic paint
- Stainless steel – natural

ELECTRICAL RATING:

- Control circuit switch – 15 AMP, 600 VAC max.

ORDERING INFORMATION:

| Contact Arrangement | Diagram | Cat # |
|---------------------|---------|--------|
| 2 normally open | | AFA20 |
| 2 normally closed | | AFAX20 |

OPTIONS:

| Description | Suffix |
|---|--------|
| Finish: Corro-free™ epoxy powder coat – for coating outside only. | S752 |

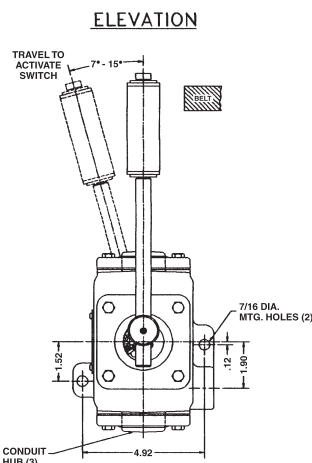

*Dimensions are approximate, not for construction purposes.

AFU Mine Signal Switch

APPLICATIONS:

AFU mine signal switches are used:

- For signalling circuits or remote control of magnetic motor starters
- In non-hazardous areas of mines or process industry facilities where a rugged enclosure is needed for protection from falling ore and other material or dripping water
- Mounted on walls or in shaft ways and actuated by pulling line or cable attached to the loop at the bottom

FEATURES:

- Sturdy rain-tight enclosure with heavy mounting lugs
- Wires enter enclosure through clearance holes in the underside
- Switches are actuated by a spring-loaded plunger which returns to the normal position when the operating force is removed
- Units are furnished with heavy duty motor control push buttons. Several of these may be interconnected electrically for remote control of a magnetic motor starter from more than one location

ORDERING INFORMATION:

| Maximum Weight of Line or Cable Without Actuating Switch (lbs.) | Total Operating Force Required (lbs.) | With Pushbutton Heavy Duty 600 VAC Max. Cat # |
|---|---------------------------------------|---|
| 25 | 50 | AFU254 |
| 15 | 25 | AFU154 |

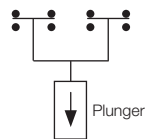

CERTIFICATIONS AND COMPLIANCES:

AFU Series

- NEMA: 3

STANDARD MATERIALS:

- Enclosure – Feraloy® iron alloy
- Plunger – steel
- Loop – bronze

STANDARD FINISHES:

- Feraloy® iron alloy – electrogalvanized and aluminum acrylic paint
- Steel – electrogalvanized
- Bronze – natural



AFU mine signal switch with push button switch (cover removed)

DIMENSIONS (IN INCHES*):

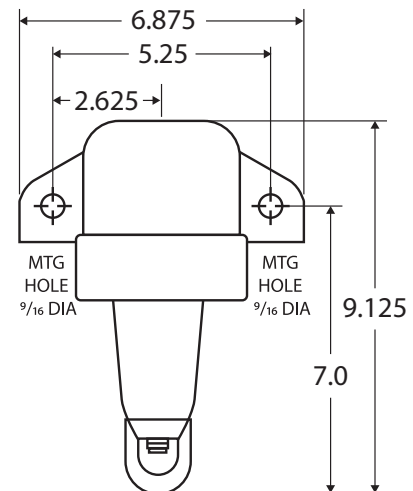

*Dimensions are approximate, not for construction purposes.

AFC Mine Signal Switch

APPLICATIONS:

AFC mine signal switches are used:

- For remote control of signaling circuits
- In non-hazardous areas of mines or process industry facilities where a rugged enclosure is needed for protection from falling ore and other material or dripping water
- Mounted on walls or in shaft ways and actuated by pulling line or cable attached to the loop at the bottom

FEATURES:

- Cast Feraloy® housing
- Mounting lugs for ½” bolts or lag screws
- Single pole normally open double break switch contacts
- Switch is actuated by a spring-loaded plunger which returns to the normal position when the operating force is removed
- Standard pull spring on switch unit is 10 lbs
- Terminal block with heavy wire terminals is mounted in the box and readily accessible for ease of wiring
- Housing has ¾” NPT feed-through conduit hubs
- Intended for use with separate howlers, bells, horns or other signaling devices
- Heavy cast water shedding enclosure

STANDARD MATERIALS:

- Enclosure – Feraloy® iron alloy
- Cover – sheet steel
- Plunger – steel
- Loop – bronze

STANDARD FINISHES:

- Feraloy® iron alloy – electrogalvanized and aluminum acrylic paint
- Steel – electrogalvanized
- Bronze – natural

ELECTRICAL RATING:

- Control circuit switch – 15 AMP, 125 VAC max.



AFC mine signal switch

ORDERING INFORMATION

| Maximum Weight of Line or Cable Without Actuating Switch (lbs.) | Total Operating Force Required (lbs.) | Cat # |
|---|---------------------------------------|---------|
| 7 | 10 | AFC210 |
| 10 | 15 | AFC215 |
| 25 | 50 | AFC250 |
| 75 | 100 | AFC2100 |

OPTIONS:

| Description | Suffix |
|---|--------|
| Finish: Corro-free™ epoxy powder coat – for coating outside only. | S752 |

DIMENSIONS (IN INCHES*):

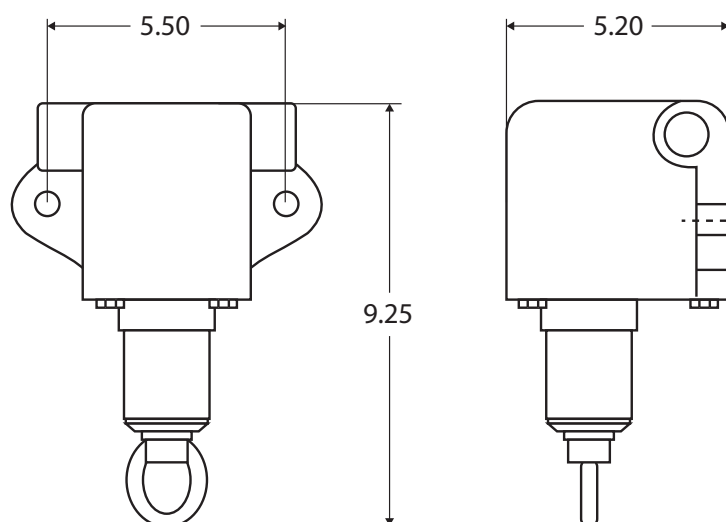

*Dimensions are approximate, not for construction purposes.

AFS Mine Signal Switch

APPLICATIONS:

AFS mine signal switches are used:

- For remote control of signaling circuits
- In non-hazardous areas of mines or process industry facilities where a rugged enclosure is needed for protection from falling ore and other material or dripping water
- Mounted on walls or in shaft ways and actuated by pulling line or cable attached to the loop at the bottom

FEATURES:

- Cast Feraloy® housing with water shedding cover
- Mounting lugs for ½” bolts or lag screws
- Single pole normally open double break switch contacts
- Switch is actuated by a spring-loaded plunger which returns to the normal position when the operating force is removed
- Standard pull spring on switch unit is 10 lbs
- Terminal block with heavy wire terminals is mounted in the box and readily accessible for ease of wiring
- Housing has ¾” NPT conduit hub on the bottom and slide-on steel, water shedding cover for convenient access
- No tools required, no screws to remove, no wiring to disturb for inspection or switch replacement

STANDARD MATERIALS:

- Enclosure – Feraloy® iron alloy
- Cover – sheet steel
- Plunger – steel
- Loop – bronze

STANDARD FINISHES:

- Feraloy® iron alloy – electrogalvanized and aluminum acrylic paint
- Steel – electrogalvanized
- Bronze – natural

ELECTRICAL RATING:

- Control circuit switch – 15 AMP, 125 VAC max.



AFS mine signal switch

ORDERING INFORMATION:

| Maximum Weight of Line or Cable Without Actuating Switch (lbs.) | Total Operating Force Required (lbs.) | Cat # |
|---|---------------------------------------|------------|
| 7 | 10 | AFS210-CD |
| 10 | 15 | AFS215-CD |
| 25 | 50 | AFS250-CD |
| 75 | 100 | AFS2100-CD |

OPTIONS:

| Description | Suffix |
|---|--------|
| Finish: Corro-free™ epoxy powder coat – for coating outside only. | S752 |

DIMENSIONS (IN INCHES*):

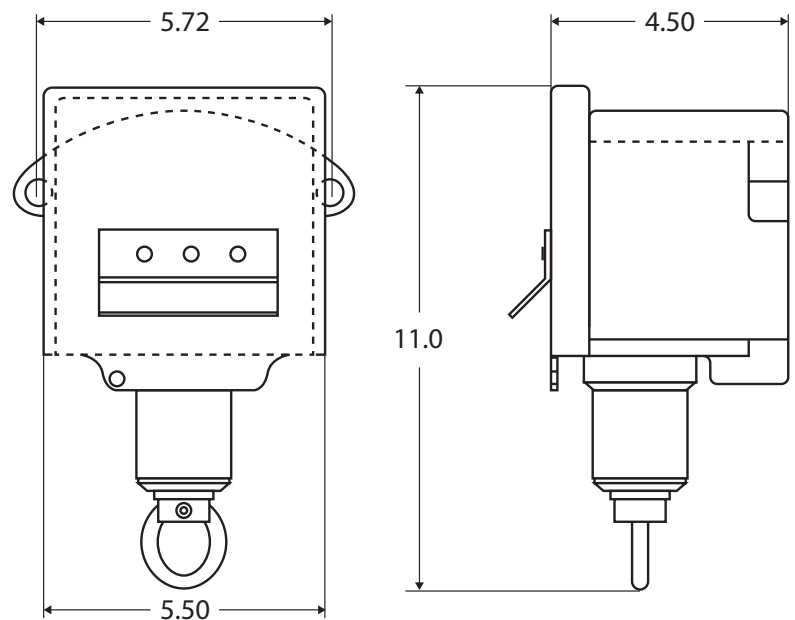

*Dimensions are approximate, not for construction purposes.

AFM Mine Signal Switch

APPLICATIONS:

AFM mine signal switches are used:

- For audible signaling and remote signaling
- In non-hazardous areas of mines or process industry facilities where a rugged enclosure is needed for protection from falling ore and other material or dripping water
- Mounted on walls or in shaft ways and actuated by pulling line or cable attached to the loop at the bottom

FEATURES:

- Cast Feraloy® housing with sheet steel water shedding cover
- Mounting lugs for ½” bolts or lag screws
- Single pole normally open double break switch contacts
- Switch is actuated by a spring-loaded plunger which returns to the normal position when the operating force is removed
- Standard pull spring on switch unit is 10 lbs
- Buzzer provides audible signal
- Terminal block with heavy wire terminals is mounted in the box for ease of wiring
- Housing has ¾” conduit hub on bottom and slide-on steel, water shedding cover for convenient access
- No tools required, no screws to remove, no wiring to disturb for inspection or replacement of internal units
- 10 watt continuous duty resistor mounted in panel to keep interior dry

ORDERING INFORMATION:

| Maximum Weight of Line or Cable Without Actuating Switch (lbs.) | Total Operating Force Required (lbs.) | Cat # |
|---|---------------------------------------|--------------|
| 7 | 10 | AFM211060 |
| 10 | 15 | AFM2110605 |
| 25 | 50 | AFM21106050 |
| 75 | 100 | AFM211060100 |

OPTIONS:

| Description | Suffix |
|---|--------|
| Finish: Corro-free™ epoxy powder coat – for coating outside only. | S752 |

STANDARD MATERIALS:

- Enclosure – Feraloy® iron alloy
- Cover – sheet steel
- Plunger – steel
- Loop – bronze

STANDARD FINISHES:

- Feraloy® iron alloy – electrogalvanized and aluminum acrylic paint
- Steel – electrogalvanized
- Bronze – natural

ELECTRICAL RATING:

- Control circuit switch – 15 AMP, 125 VAC max.



AFM mine signal switch

DIMENSIONS (IN INCHES*):

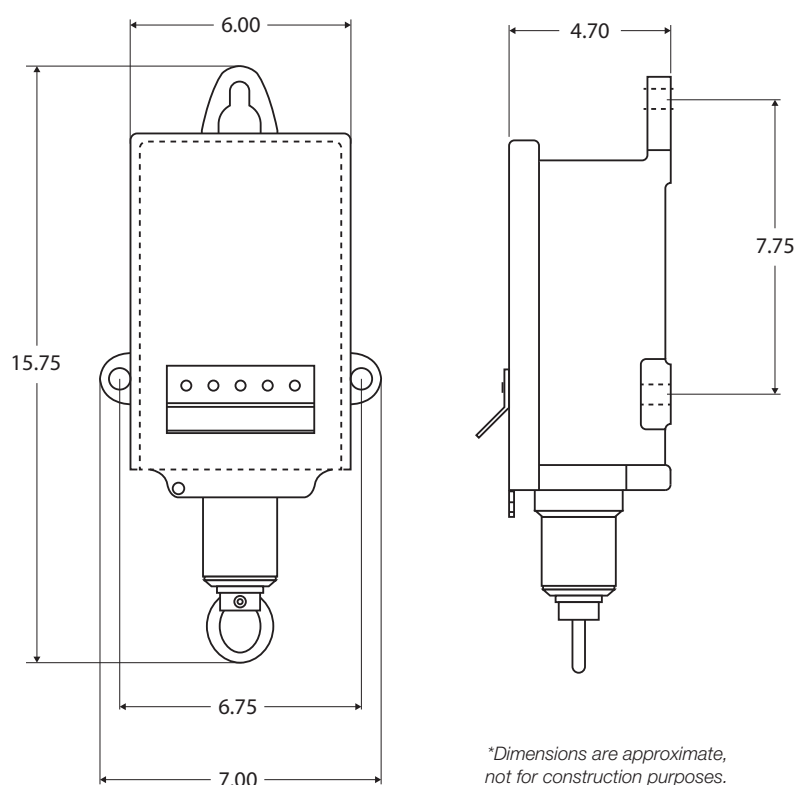

*Dimensions are approximate, not for construction purposes.

AFK Mine Signal Switch

APPLICATIONS:

AFK mine signal switches are used:

- For visible, audible and remote control of signaling circuits
- In non-hazardous areas of mines or process industry facilities where a rugged enclosure is needed for protection from falling ore and other material or dripping water
- Mounted on walls or in shaft ways and actuated by pulling line or cable attached to the loop at the bottom

FEATURES:

- Cast Feraloy® housing with water shedding cover
- Mounting lugs for ½” bolts or lag screws
- Single pole normally open double break switch contacts
- Switch is actuated by a spring-loaded plunger which returns to the normal position when the operating force is removed
- Standard pull spring on switch unit is 10 lbs
- Visible signal observable from the front and both sides through portholes
- Buzzer provides audible signal
- Terminal block with heavy wire terminals is mounted in the housing and readily accessible for ease of wiring
- Housing has ¾” conduit hub on bottom and slide-on steel, water shedding cover for convenient access
- No tools required, no screws to remove, no wiring to disturb for inspection or replacement of internal units
- 10 watt continuous duty resistor mounted in panel to keep interior dry

ORDERING INFORMATION:

| Maximum Weight of Line or Cable Without Actuating Switch (lbs.) | Total Operating Force Required (lbs.) | Cat # |
|---|---------------------------------------|--------------|
| 7 | 10 | AFK211060 |
| 10 | 15 | AFK2110605 |
| 25 | 50 | AFK21106050 |
| 75 | 100 | AFK211060100 |

OPTIONS:

| Description | Suffix |
|---|--------|
| Finish: Corro-free™ epoxy powder coat – for coating outside only. | S752 |

STANDARD MATERIALS:

- Enclosure – Feraloy® iron alloy
- Cover – sheet steel
- Plunger – steel
- Loop – bronze

STANDARD FINISHES:

- Feraloy® iron alloy – electrogalvanized and aluminum acrylic paint
- Steel – electrogalvanized
- Bronze – natural

ELECTRICAL RATING:

- Control circuit switch – 15 AMP, 125 VAC max.



AFK mine signal switch

DIMENSIONS (IN INCHES*):

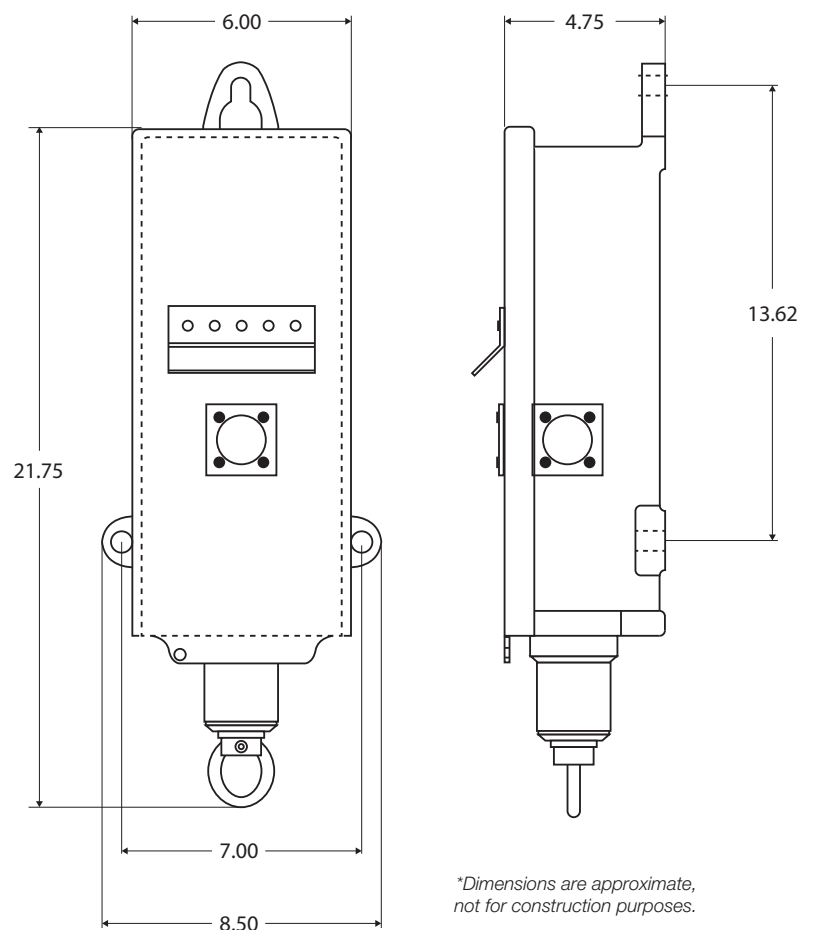

*Dimensions are approximate, not for construction purposes.

Hazardous Areas & Equipment Tables

AREA CLASSIFICATION

| REGULATORY ORGANIZATION | HAZARD | FLAMMABLE MATERIAL PRESENT CONTINUOUSLY | FLAMMABLE MATERIAL PRESENT INTERMITTENTLY | FLAMMABLE MATERIAL PRESENT ABNORMALLY |
|-------------------------|-----------|---|---|---------------------------------------|
| IEC/ATEX | Gas/Vapor | Zone 0 | Zone 1 | Zone 2 |
| | Dust | Zone 20 | Zone 21 | Zone 22 |
| NEC® 501 | Gas/Vapor | Class I, Division 1 | Class I, Division 1 | Class I, Division 2 |
| NEC® 505 | Gas/Vapor | Class I, Zone 0 | Class I, Zone 1 | Class I, Zone 2 |
| NEC® 502 | Dust | Class II, Division 1 | Class II, Division 1 | Class II, Division 2 |
| NEC® 506 | Dust | Zone 20 | Zone 21 | Zone 22 |
| CA CEC Sec. 18 | Gas/Vapor | Class I, Zone 0 | Class I, Zone 1 | Class I, Zone 2 |
| CA CEC Sec. 18 | Dust | Class II, Division 1 | Class II, Division 1 | Class II, Division 2 |

- Items suitable for hazardous areas are indicated as such
- CA Classification PER CSAC22.1 Canadian Electrical Code (CEC Section 18 or Anex J)
- EU Classification per EN 60079-10
- US Classification per ANSI/NFPA 70 National Electrical Code® (NEC®) Article 500 or Article 505

GAS/EQUIPMENT GROUPING

| TYPICAL GAS | US (NEC® 505) • CA (CEC SECTION 18) • EU • IEC | US (NEC® 500) • CA (CEC ANNEX J) |
|-------------|--|----------------------------------|
| Acetylene | Group IIC | Class I Group A |
| Hydrogen | (Group IIB + H ₂) | Class I Group B |
| Ethylene | Group IIB | Class I Group C |
| Propane | Group IIA | Class I Group D |
| Methane | Group I* | Mining* |

*Not within scope of NEC®, under jurisdiction of MSHA. Not within scope of CEC

INGRESS PROTECTION (IP) CODES

| CODE | FIRST CHARACTERISTIC NUMERAL | SECOND CHARACTERISTIC NUMERAL |
|---|--|----------------------------------|
| 1ST OR 2ND Numeral | Protection Against Solid Bodies | Protection Against Liquid |
| 0 | No protection | No protection |
| 1 | Objects greater than 50 mm | Vertical (90°) dripping water |
| 2 | Objects greater than 12 mm | 70° to 90° dripping water |
| 3 | Objects greater than 2.5 mm | Sprayed water |
| 4 | Objects greater than 1 mm | Splashed water |
| 5 | Dust-protected | Water jets |
| 6 | Dust-tight | Heavy seas |
| 7 | - | Effects of immersion |
| 8 | - | Indefinite immersion |

APPROXIMATE U.S. ENCLOSURE TYPE EQUIVALENT TO IP RATING*

| Type > IP | | Type > IP | | Type > IP | |
|-----------|----|-----------|----|------------|----|
| 1 | 10 | 3S | 54 | 6 and 6P | 67 |
| 2 | 11 | 4 and 4X | 55 | 12 and 12K | 52 |
| 3 | 54 | 5 | 52 | 13 | 54 |
| 3R | 14 | - | - | - | - |

*NEMA Enclosure Type can be converted to IP Code Rating, but IP Codes cannot be converted to NEMA Enclosure Type

Cooper Australia
Manufacturing
205-209 Woodpark Road
Smithfield NSW 2164
Australia
Tel: +61 (2) 8787 2777
Fax: +61 (2) 9609 2342

Cooper Latin America
R. Placido Vieira, 79
Santo Amaro, Sao Paulo, Brazil
Tel: +55 (11) 5641 3451
Fax: +55 (11) 5641 2127

Cooper Technology Centre
Level 2, Quad 2
8 Parkview Drive
Sydney Olympic Park NSW 2127
Australia
Tel: +61 (2) 8787 2777
Fax: +61 (2) 9609 2342
www.cooperindustries.com

Cooper B-Line
509 West Monroe Street
Highland, IL 62249
Tel: (800) 851-7415
Fax: (618) 654-1917
www.cooperbline.com

Cooper Crouse-Hinds
Wolf & Seventh North Streets
Syracuse, NY 13221
Tel: (866) 764-5454
Fax: (315) 477-5179
www.crouse-hinds.com

Cooper Power Systems
2300 Badger Drive
Waukesha, WI 53188
Tel: (877) 277-4636
Fax: (262) 691-9330
www.cooperpower.com

Cooper Wiring Devices
203 Cooper Circle
Peachtree City, GA 30269
Tel: (866) 944-0043
Fax: (800) 329-3055
www.cooperwiringdevices.com

Cooper Bussmann
114 Old State Road
St. Louis, MO 63021
Tel: (636) 394-2877
Fax: (866) 715-0769
www.cooperbussmann.com

Cooper Lighting
Customer First Center
1121 Highway 74 South
Peachtree City, GA 30269
Tel: (770) 486-4800
Fax: (770) 486-4801
www.cooperlighting.com

Cooper Safety
Jephson Court, Tancred Close
Royal Leamington Spa
Warwickshire CV31 3RZ
United Kingdom
Tel: +44 1926-439200
Tel: (800) 631-2148
www.cooper-safety.com



B-Line
Bussmann
Crouse-Hinds
Lighting
Power Systems
Safety
Wiring Devices

The trade names and brand names contained herein are valuable trademarks of Cooper Industries in the U.S. and other countries. You are not permitted to use the Cooper Trademarks without the prior written consent of Cooper Industries.

Cooper US, Inc.
600 Travis, Ste. 5600
Houston, TX 77002-1001
www.cooperindustries.com

