

# TECHNICAL INFORMATION BULLETIN

## ORDERING INFORMATION

Order code: **10036**  
 Description: **BHPS1000/QUADTAP/C/CWA/H/K/STD**  
 Internal code: **BALS1000QCA**  
 UPC: **69549100367**  
 Warranty: **3 Years**  
 Certification:   
 1029D  
 E244127

## GENERAL INFORMATION

Ballast type: **Magnetic high pressure sodium**  
 Ballast style: **Core and coil**  
 Circuit type: **CWA**  
 ANSI code: **S52**  
 Input voltage (V): **120/208/240/277**  
 Input frequency (Hz): **60**  
 Line volt regulation: **± 10%**  
 Line watt regulation: **Within trapezoid**  
 Insulation class: **H(180°)**

Input voltage (V)	Operating current (A)	Open circuit current (A)	Starting current (A)	Rated lamp watts (W)	Input watts (W)	OCV (V)	Dropout voltage (V)	UL 1029 code	Fuse rating (A)	Input current (A)	Power factor	Starting temperature
120	9.50	4.81	7.60	1 000	1 100	435	90	D	25	6.00 - 8.00	90%	-40° F / -40° C
208	5.50	3.00	4.30	1 000	1 100	435	155	C	15	3.40 - 4.70	90%	-40° F / -40° C
240	4.80	2.60	3.75	1 000	1 100	435	180	D	10	2.90 - 4.00	90%	-40° F / -40° C
277	4.10	2.20	3.27	1 000	1 100	435	208	D	10	2.50 - 3.45	90%	-40° F / -40° C

## HIGH POTENTIAL TEST (V)

1 minute:	2 000
2 seconds:	2 500
OCV test:	400 - 475
Short circuit:	6.70 - 7.50

## BALLAST DIMENSIONS

Dimension A (in.):	3.81
Dimension B (in.):	6.00
Lead Lengths (in.):	12.00
Weight (lbs):	29.00

## CASE DIAGRAM

4 1/4" x 6" Core

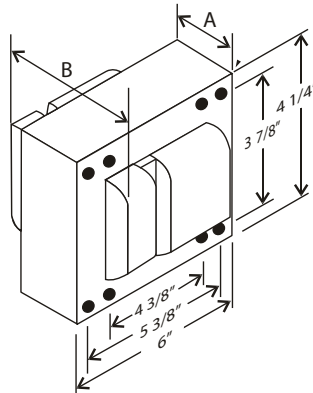

## WIRING DIAGRAM

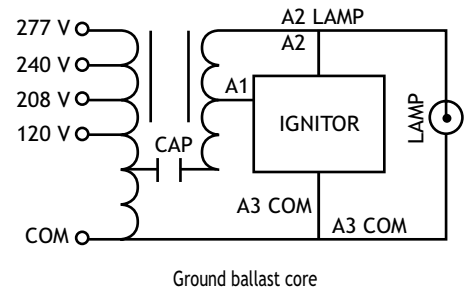

## BRACKET

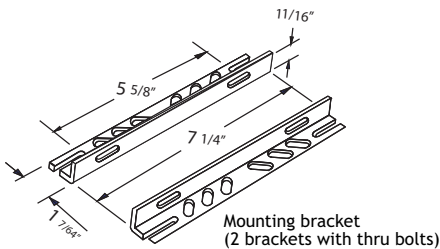

## CAPACITOR

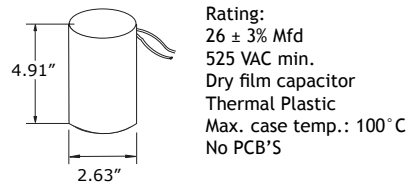

## IGNITOR

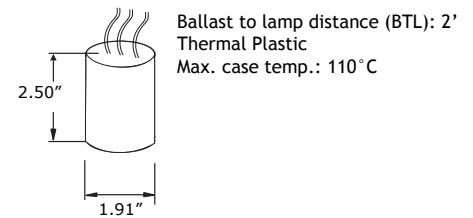

Data is based upon tests performed in a controlled environment and representative of relative performance. Actual performance can vary depending on operating conditions. Specifications are subject to change without notice.



www.standardpro.com